

MODEL 5020-A FLUID APPLIED BRAKE CALIPER

The 5020 is a scaled-up brake caliper from the model 5019. However, it has a much higher clamping force, and therefore fits into the medium to heavy-duty application range. The shoes are detachable from the shoe bearings, and shims can be installed between the brake shoe and bearing to adapt to discs of various thicknesses. The fluid-applied actuator is of the diaphragm type. A maximum pressure of 100 psi (6.9 bar) can be applied to this actuator assembly. The brake force is directly proportional to the fluid pressure in the actuator. Two pipe connections are provided on the actuator. These pipe ports are common internally, and therefore in most cases, only one input connection is sufficient for the normal application. Because of its all bronze and stainless steel construction, you can expect many years of trouble-free service from this unit.

Kobelt have developed a whole new series of brake discs to go with the caliper because of its high popularity. The discs start out at 12 inches in diameter, and are available in 3 inch increments up to 30 inches. These discs are all ventilated, and serve all segments of industry.

SPECIFICATIONS

Clamping force	9160 lbf	(40.7 kN)
Max. disc thickness	1.25 in.	(32 mm)
Req. disc face	2½ in.	(63.5 mm)
Total lining area	26 sq. in.	(168 sq. cm)
Lining thickness	0.375 in.	(9.5 mm)
Max. allowable lining wear	0.2 in.	(5 mm)
Average wear rate	0.005 cu. in./HP-hr	(0.082 c.c./HP-hr)
Coefficient of friction	0.45 – 0.5	at 20° - 260°C
Maximum pressure	100 psi	(6.9 bar)
Actuator volume	30 cu. in.	(492 cu. cm)
Weight	36 lb.	(16 kg)
Material	Die cast silicon bronze with stainless steel hardware	

IMPORTANT: Use only hydraulic fluid or air. Standard seals are NOT compatible with brake fluid.

ORDERING INFORMATION

5020-A Fluid applied brake with standard foot

When ordering brake calipers for discs smaller than the standard thickness, add the last four digits of the appropriate shim kit to the part number. Example: 5020-A 0750 is for 5020-A caliper set for 3/4" thick disc.

A variety of custom made discs are available. For discs thinner than the standard thickness refer to the shim kit table below.

KOBELT STANDARD VENTILATED DISCS: 1.25 in. (32 mm)

Disc Diameter	12	15	18	21	24	27	30
inches	12	15	18	21	24	27	30
mm	305	381	457	533	610	686	762
Acting Radius							
ft	0.396	0.521	0.646	0.771	0.896	1.021	1.146
meter	0.121	0.159	0.197	0.235	0.273	0.311	0.349
Torque ‡							
ft-lb	1805	2375	2945	3515	4085	4655	5225
kg-m	250	328	407	486	565	644	722
Maximum RPM	4600	3650	3000	2550	2250	1980	1780

‡ Brake torques are theoretically calculated values

Max disc thickness	Shim Kit	
	Part Number	Total shim size
0.75 in. (19 mm)	5020-0750	0.50 in. (12.7 mm) 1 shim (¼") per side
0.50 in. (12.7mm)	5020-0500	0.75 in. (19 mm) 1 shim (3/8") per side

DIMENSIONS AND PARTS LIST 5020-A

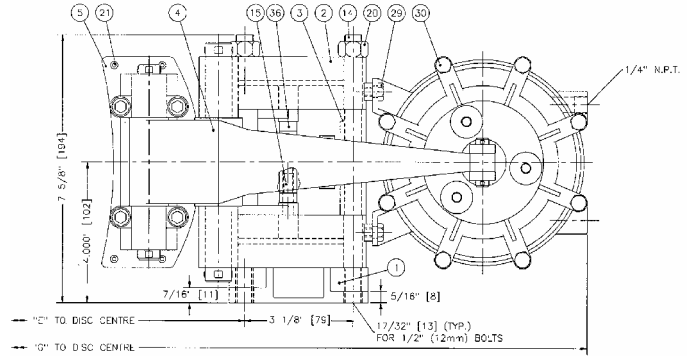
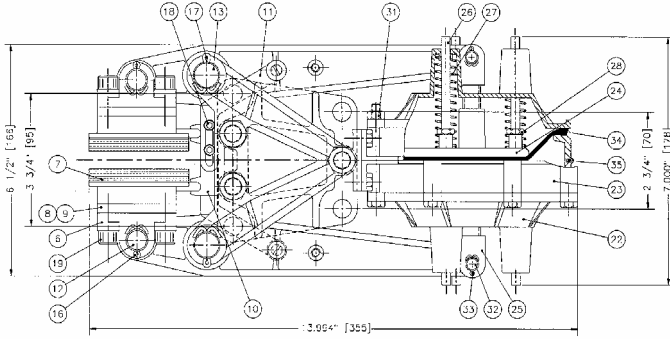

All dimensions in inches (mm)

Disc diameter							
inches	12	15	18	21	24	27	30
mm	305	381	457	533	610	686	762
Dimension "E"							
inches	7.25	8.75	10.25	11.75	13.25	14.75	16.25
mm	184	222	260	298	337	375	413
Dimension "G"							
inches	17.25	18.75	20.25	21.75	23.25	24.75	26.25
mm	438	476	514	552	591	629	667

Item	Qty	Part No.	Description
1	1	5020-0001	Foot
2	2	5020-0002	Saddle
3	3	5020-0003	Spacer
4	2	5021-0004	Lever
5	2	5020-0005	Shoe
6	4	5021-0006	Hinge Block
7	2	5020-0007	Lining
8	*	5021-0008	1/4" Shim
9	*	5021-0009	3/8" Shim
10	2	5020-0011	Balancing Link No. 1
11	2	5020-0012	Balancing Link No. 2
12	2	5021-0021	Shoe Pin
13	2	5020-0022	Saddle Pin
14	3	5020-0023	Tie Rod
15	2	5021-0126	Link Pin
16	4	1026-0516	Cotter Pin
17	4	1026-0824	Cotter Pin
18	4	1002-0808	Socket Hd. Screw
19	8	1002-1216	Socket Hd. Cap Screw (standard)
19	8*	1002-1220	Socket Hd. Cap Screw (5020-0750 shim kit)
19	8*	1002-1224	Socket Hd. Cap Screw (5020-0500 shim kit)
20	3	1022-0114	Nut
21	22	1033-0807	Rivet
36	2	5020-0027	Spacer

* Quantity may vary with options

6112 Fluid Applied Pot			
Item	Qty	Part No.	Description
22	2	6112-0001	End Cap
23	2	6112-0002	Centre Housing
24	2	6112-0003	Diaphragm Washer
25	2	6112-0005	Pot Clevis
26	6	6112-0007	Guide Pin
27	6	1201-0146	Spring
28	6	1022-0210	Jam Nut
29	4	1001-1008	Hex. Hd Screw
30	8	1001-1044	Hex. Hd Screw
31	8	1022-0410	Nut - plated
32	2	6112-0010-L	Pin
33	4	1026-0312	Cotter Pin
34	2	1105-0012	Diaphragm
35	1	1101-0161	"O" Ring