

5020-S SPRING APPLIED BRAKE CALIPER

The model 5020-S brake caliper is the same basic design as model 5019, but is a much more powerful unit with a bigger shoe area. These calipers are designed for stopping and energy absorbing applications.

A special brake disc series (12-30 inches diameter), with superb ventilation and energy capabilities was designed to go with the 5020 brake caliper, providing virtually unlimited applications in all industries for stopping and braking. The application force is absolutely proportional to the actuator force. Consequently varying the control pressure at the actuator will allow smooth and positive response.

All Kobelt brakes are equipped with patented balancing links which provide equal brake lining wear on both brake shoes and also across the shoe itself.

SPECIFICATIONS

Clamping force	9160 lbf.	(40.7 kN)
Max. disc thickness	1.25 in.	(32 mm)
Req. disc face	2½ in.	(63.5 mm)
Total lining area	26 sq. in.	(168 sq. cm)
Lining thickness	0.375 in.	(9.5 mm)
Max. allowable lining wear	0.20 in.	(5.0 mm)
Average wear rate	0.005 cu. in./HP-hr	(0.082 cu. cm/HP-hr)
Coefficient of friction	0.45 – 0.5	at 20° - 260°C
Max. release pressure	120 psi	(8.3 bar)
Max. pressure	250 psi	(17 bar)
Actuator volume	19 cu. in.	(311 cu. cm)
Weight	42 lb.	(19 kg)
Materials	Die cast silicon bronze with stainless steel hardware	

ORDERING INFORMATION

5020-S	Spring Applied Brake Caliper
5020-SR	Spring Applied Brake Caliper with manual release screw

Important: Use only hydraulic fluid or air. Standard seals are not compatible with brake fluid.

When ordering brake calipers for discs smaller than the standard thickness of 1¼", shim kits are available for adjustment. Add the last four digits of the appropriate kit to the code when ordering.

Example: 5020-S0750 is for a 5020-S brake caliper set for ¾" thick disc.

STANDARD VENTILATED KOBELT DISC: 1.25 in. (32 mm)

Disc Dia.	12	15	18	21	24	27	30
inches	12	15	18	21	24	27	30
mm	305	381	457	533	610	686	762
Acting Rad.							
ft	.396	.521	.646	.771	.896	1.021	1.146
meter	.121	.159	.197	.235	.273	.311	.349
Torque ‡							
ft-lb	1805	2375	2945	3515	4085	4655	5225
kg-m	250	328	407	486	565	644	722
Maximum RPM	4600	3650	3000	2550	2250	1980	1780

‡ Brake torques are theoretical values only

A variety of custom made disc are available. For discs smaller than the standard thickness, refer to the shim kit table below.

Disc thickness	Shim Kit Part number	Total shim size
0.75 in. (19 mm)	5020-0750	0.50 in (12.7 mm) 1 shim (1/4") per side
0.50 in. (12.7 mm)	5020-0500	0.75 in (19 mm) 1 shim (3/8") per side

MODEL 5020-S

Note: Springs are made of carbon steel

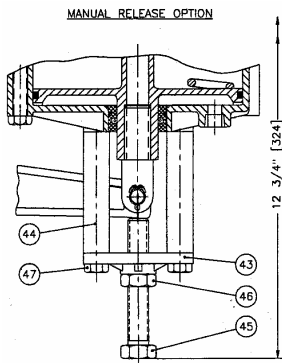
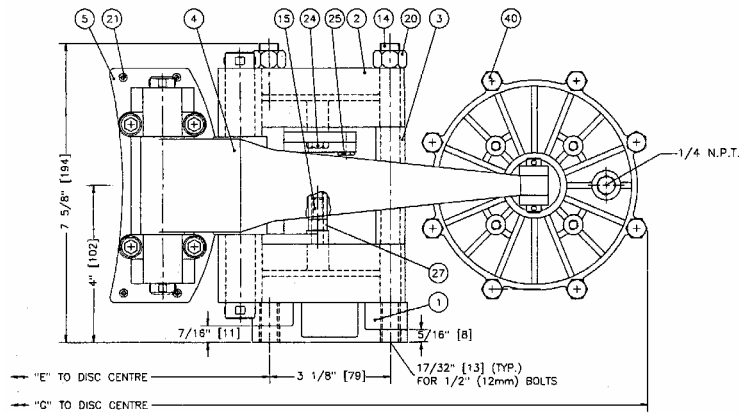
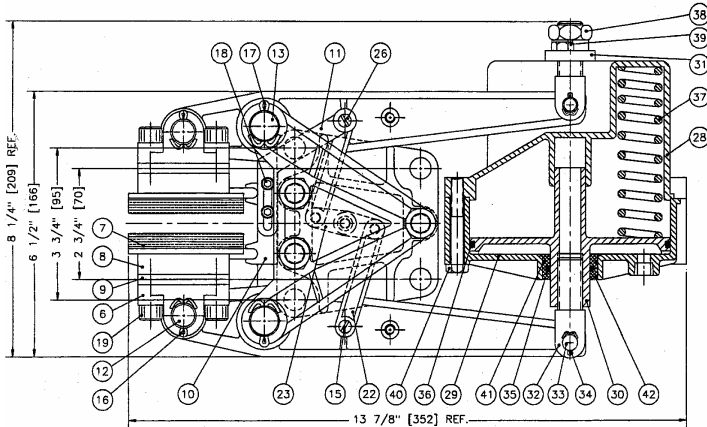

All dimensions in inches (mm)

Disc diam	12	15	18	21	24	27	30
inches	12	15	18	21	24	27	30
mm	305	381	457	533	610	686	762
Dim. "E"	7.25	8.75	10.25	11.75	13.25	14.75	16.25
inches	7.25	8.75	10.25	11.75	13.25	14.75	16.25
mm	184	222	260	298	337	375	413
Dim. "G"	17.25	18.75	20.25	21.75	23.25	24.75	26.25
inches	17.25	18.75	20.25	21.75	23.25	24.75	26.25
mm	438	476	514	552	591	629	687

Item	Qty	Part No.	Description
1	1	5020-0001	Foot
2	2	5020-0002	Saddle
3	3	5020-0003	Spacer
4	2	5021-0004	Lever
5	2	5020-0005	Shoe
6	2	5021-0006	Hinge Block
7	2	5020-0007	Lining
8	*	5021-0008	1/4" Shim
9	*	5021-0009	3/8" Shim
10	2	5020-0011	Balancing Link No. 1
11	2	5020-0012	Balancing Link No. 2
12	2	5021-0021	Shoe Pin
13	2	5020-0022	Saddle Pin
14	3	5020-0023	Tie Rod
15	2	5021-0126	Link Pin
16	4	1026-0516	Cotter Pin
17	4	1026-0824	Cotter Pin
18	4	1002-0808	Socket Hd Screw
19	8	1002-1216	Socket Hd Screw (standard)
19*	*	1002-1220	Socket Hd Screw (-1000/-0750 shim)
20	3	1022-0114	Nut
21	22	1033-0807	Rivet
22	2	5020-0010	Connecting Link
23	1	5020-0019	Centre Pivot Link
24	1	5020-0024	Shoulder Bolt
25	2	5020-0025	Shoulder Bolt
26	1	5021-0026	Link Pin
27	1	5020-0027	Spacer

6212 Spring Applied Pot

28	1	6212-0001	Spring Housing
29	1	6212-0002	Piston Housing
30	1	6212-0003	Piston
31	1	6212-0004	Bracket
32	1	6212-0005L	Clevis, long
32	1	6212-0005S	Clevis, short
33	2	6112-0010-L	Pin
34	4	1026-0312	Cotter Pin
35	1	1101-0214	"O" Ring
36	1	1101-0248	"O" Ring
37	8	1201-0035	Spring
38	1	1022-0216	Jam Nut
39	2	1001-1112	Hex Hd Bolt
40	8	1001-1136	Hex Hd Bolt
41	1	1101-0026	"O" Ring
42	1	6212-PHB	Bushing

Manual Release Option

43	1	6212-0006	Manual Release Bracket
44	4	6212-0007	Spacer
45	1	1001-1448	Release Screw
46	1	1022-0214	Jam Nut
47	4	1001-1156	Hex Hd. Bolt

* Quantity may vary with options

Caution: When dismantling the actuator, it is important that it is retained in a press before the holding screws are removed.