



### Specifications

Clamping force	32000 lbf	(142.3 kN)
Maximum disc thickness	4 in.	(102 mm)
Req. disc face	7 in.	(178 mm)
Total lining area	194 sq. In.	(1251 sq. mm)
Lining thickness	0.625 in.	(15.8 mm)
Max. allowable lining wear	0.420 in.	(10.6 mm)
Average wear rate	0.005 cu.in./HP-hr	(0.082 cu.cm/HP-hr)
Coefficient of friction	0.45 – 0.49	at 20° - 260°C
Maximum pressure	100 P.S.I.	(6.9 bar)
Weight	202 lbs	(92 kg)
Material	Die cast silicon bronze with stainless steel hardware and alloy steel studs	
	Air actuator is supplied by a prominent industrial actuator manufacturer	

### ACCESSORIES AVAILABLE

Standard Shim Kit  
5026-3500 Shim Kit  
5026-3000 Shim Kit  
5026-2500 Shim Kit

## **MODEL 5026-CM Air/Spring Applied Brake**

US Patent 7,857,109 B2

This caliper is operated by an automotive brake actuator. The brake actuator, mostly used on medium and heavy duty trucks, has a dual function. The upper housing has a spring which is forcing the actuator rod downward, pushing the wedge against the rollers and applying the brake. Air pressure is required to overcome the spring to put the brake into a released position. If there is no air pressure going to the actuator, the upper brake portion applies the brake providing emergency braking.

The lower portion of the actuator is a diaphragm that also pushes the rod downward and applies the brake proportionately. A very light return spring pushes the wedge upward

to release the brake. This allows for the brake to be used in two different versions. The upper spring can only provide up to 60% of brake force. In order to modulate the brake, the air pressure can be varied in the diaphragm portion. Since there is no piston in this actuator assembly, there is practically no hysteresis, as far as the actuator is concerned. This makes it extremely sensitive to varying air pressures.

The wedge mechanism consists of a wedge and rollers that force the levers apart to apply pressure to the brake disc and give a very accurate control over the brake torque.

# Model 5026-CM Air/Spring Applied Brake

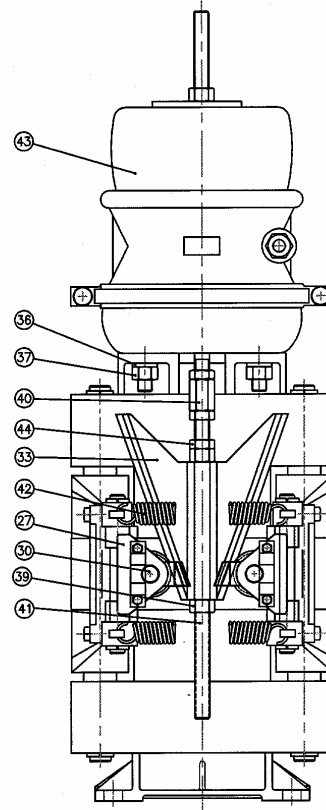
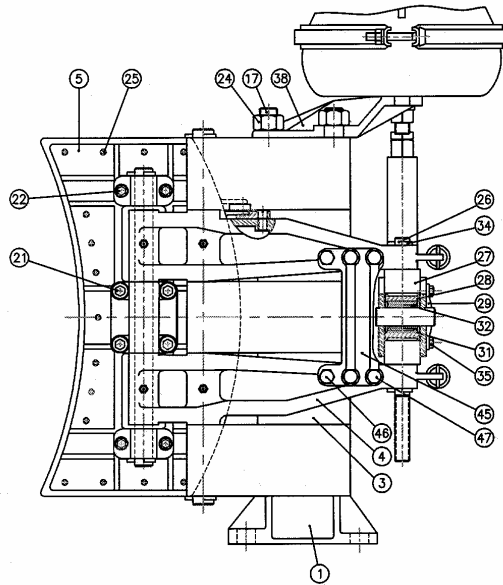
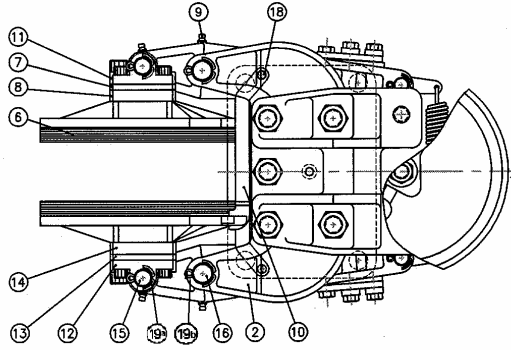

Item	Qty	Part No.	Description
1	1	5025-0001	Foot
2	3	5026-0002	Saddle
3	2	5026-0003	Spacer
4	4	5026-1004	Lever
5	2	5026-0005	Shoe
6	2	5026-0007	Lining
7	*	5026-0008	Shim 1/4" (Centre Hinge)
8	*	5026-0009	Shim 1/2" (Centre Hinge)
9	8	1501-0301	Grease Nipple
10	2	5026-0030	Balancing Link
11	2	5026-0013	Centre Hinge Block
12	4	5026-0014	Outer Hinge Block
13	*	5026-0015	Shim 1/4" (Outer Hinge)
14	*	5026-0016	Shim 1/2" (Outer Hinge)
15	2	5026-0027	Shoe Pin
16	2	5026-0028	Pin (Saddle)
17	5	5027-0023	Tie Rod †
18	2	5024-0026	Link Pin
19	4	1039-0352	Hitch Pin, 3/16"
19	4	1039-0470	Hitch Pin, 1/4"
20	4	1023-0232	Flat Washer
21	8	1002-1420	Skt Hd. Cap Screw (standard)
21	*	1002-1424	Skt Hd. Cap Screw (-3500 Shim kit)
21	*	1002-1428	Skt Hd. Cap Screw (-3000 Shim kit)
21	*	1002-1432	Skt Hd. Cap Screw (-2500 shim kit)
22	8	1002-1220	Skt Hd. Cap Screw (standard)
22	*	1002-1224	Skt Hd. Cap Screw (-3500 Shim kit)
22	*	1002-1228	Skt Hd. Cap Screw (-3000 Shim kit)
22	*	1002-1232	Skt Hd. Cap Screw (-2500 Shim kit)

Item	Qty	Part No.	Description
23	4	1002-1010	Socket Hd. Cap Screw
24	5	1022-0117	Hex Nut
25	58	1033-1007	Rivet
26	2	5026-0017	Roller Pin
27	2	5026-0151	Roller Box
28	2	5026-0019	Roller
29	2	5026-0041	Locking Plate
30	2	5026-0021S	Roller Shaft
31	2	5026-0022	Roller Bearing BH-1620
32	2	5026-0023	Roller IR-1220
33	1	5026-0153	Wedge
34	4	1026-0516	Cotter Pin 1/8" x 1"
35	4	1001-1008	Hex Head Cap Screw
36	2	1023-0316	Lock Washer
37	2	1022-0116	Reg. Nut
38	1	5026-0052	Mounting Bracket
39	2	1022-0166	Reg. Nut
40	1	5026-0025	Connecting Nut
41	1	5026-0026	Extension Push Rod
42	2	1202-0003S	Return Spring
43	1	3636	Spring Actuator
44	4	1022-0266	Jam Nut
45	2	5026-0043	Connection Bracket
46	4	1001-1216	Hex Hd Cap Screw
47	8	1001-1220	Hex Hd Cap Screw

† Tie rods are made of rolled steel

\* Quantity may vary