

## MODEL 5040-A AIR APPLIED DISC BRAKE CALIPER

The air applied model 5040 is a pneumatically operated caliper requiring only an air supply with pressure regulator. The pressure regulator can be adjusted to provide the customer with the desired torque or stopping characteristics. Two air-on actuators consisting of a double diaphragm system provide an equal force to each brake shoe when an air pressure is applied. The action of compression springs will return the caliper to the “brake-off” position when the air pressure is shut off.

Caliper 5040 is also available in a mechanically applied model. A 5400 lb. pulling force is required to drive a wedge between the two brake arm levers thereby applying the brake.

Both types employ the balancing link which ensures equal wear on both linings.

### CALIPER

Total normal force	52560 lbf (233.8 kN)
Total lining area	536 in <sup>2</sup> (3458 cm <sup>2</sup> )
Allowable lining wear	0.56 in. (14 mm)
Max. air pressure	100 psi (670 kPa)
Max. power input	768 hp (573 kW)
Assembly weight	570 lb. (259 kg)

### DISC – 4” (102 mm)

Disc Dia. inch	42.5	48.5	54.5	60.5	72.0	84.0	96.0
mm	(1079)	(1232)	(1384)	(1537)	(1829)	(2134)	(2438)
Acting Rad. ft	1.33	1.58	1.83	2.08	2.54	3.04	3.54
mm	(405)	(482)	(558)	(634)	(774)	(927)	(1079)
Max. RPM	1300	1100	1000	900	700	600	500

#### NOTE:

Specifications in metric units are shown in parentheses.

\* Figures are based on a continuous application of braking force. Allowable values will be higher for one-stop applications where disc is allowed to cool between uses.

For more technical information refer to Kobelt’s General Engineering section on disc brakes.

KOBELT BRAKES ARE PROTECTED UNDER ONE OR MORE OF THE FOLLOWING PATENTS.

U.S. Patent	Canada Patent
3722636	4164993
895693	
3815471	4121697
922603	
4013148	4108285
1069066	
4060153	4236608
1072025	

All data on this brake selection sheet are for reference and estimating purposes only. To ensure against the hazards of brake mis-application, the Customer is urged to consult with Kobelt Manufacturing for more information.

# DIMENSIONS AND PARTS LIST MODEL 5040-A

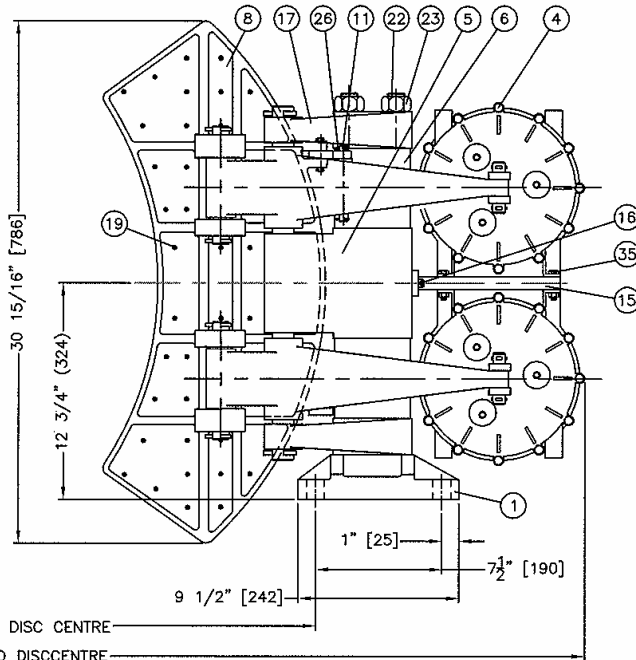
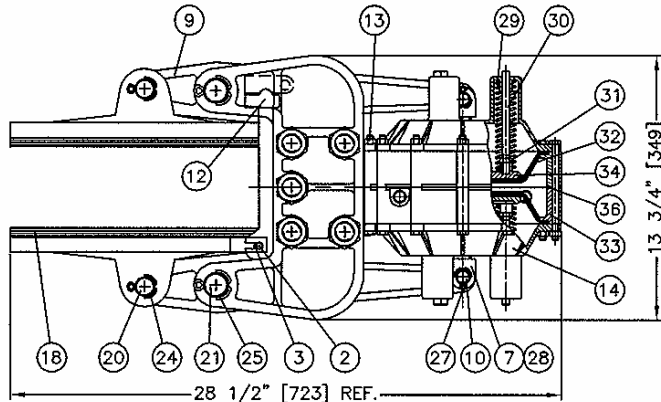

--- "E" TO DISC CENTRE  
 --- "G" TO DISCCENTRE

Item	Qty	Part No.	Description
1	1	5040-0001	Mounting foot
2	2	5040-0037	Balance link pin no. 1
3	4	1026-0510	Cotter pin
4	16	1001-1296	Hex head cap screw
5	1	5040-0005	Saddle centre
6	2	5040-0006	Saddle spacer
7	4	5040-0007	Clevis
8	2	5040-0008	Brake shoe
9	4	5040-0009	Lever
10	4	1035-1240	Pot pin
11	2	1035-0880	Balancing link pin no. 2
12	2	5040-0012	Balancing link
13	16	1022-0112	Nut
14	4	6236-0001	End cap
15	1	5040-1000	Actuator mtg. bracket
16	2	1002-1116	Socket head cap screw
17	2	5040-0017	Saddle end
18	2	5040-0018	Lining
19	104	1033-1012	Rivet
20	4	1035-16104	Shoe pin
21	2	1035-20336	Lever pivot pin
22	5	5040-0022	Tie rod
23	5	1022-0123	Nut
24	8	1026-1032	Cotter pin
25	4	1026-1140	Cotter pin
26	4	1026-0516	Cotter pin
27	8	1026-0824	Cotter pin
28	4	5040-1028	Push rod
29	12	1201-0048	Spring
30	12	6236-0004	Spring guide rod
31	12	1022-0212	Lock nut
32	4	1105-0036	Diaphragm
33	2	6236-0002	Centre Housing
34	4	6236-0003	Washer
35	8	1001-1116	Hex cap screw
35	1	1101-0270	"O" ring

All Dimensions in inches (mm)

Disc Diameter	DIM. "E"	DIM. "G"
42.5 (1080)	20.5 (521)	37.0 (940)
48.5 (1232)	23.5 (597)	40.0 (1016)
54.5 (1384)	26.5 (673)	43.0 (1092)
60.5 (1537)	29.5 (749)	46.0 (1168)
72 (1829)	35.2 (895)	51.75 (1314)
84 (2134)	41.2 (1048)	57.75 (1467)
96 (2438)	47.2 (1200)	63.75 (1619)