



U.S. Patent D593481S
European Ind. Design Reg. # 000986104-0001

MODEL 6580R Control Head (Diamond Head) – Propulsion & Steering

The 6580R Diamond Head Control was developed to provide the ultimate convenience of having steering and propulsion all in one control. With its robust design, constructed entirely in bronze and stainless steel, the 6580R Diamond Head* is complete with dual handles, membrane switches and simulated RPM and clutch indicators with a rotary base for steering control.

This unique control allows you to operate twin engines electronically via the handles or in back-up mode via the touch membrane switches. The forward, neutral and reverse switches on either side of the control allows you to operate the gear box from neutral to forward or reverse without moving the handles. In order to operate in back up mode both diamonds must be pushed simultaneously. The (+) and (-) button will increase or decrease the engine speed. The centrally located keypad consists of the Station Select, Station Lock, Throttle Override and Engine Synchronization.

The 6580R Diamond Head Control is compatible with the popular Kobelt Mighty Mariner System. The Full Follow Up steering interfaces perfectly with the Kobelt power steering system.

Note * for twin engine use only.
* not suitable for exterior applications

Options available: color – black (B), white (W)
function – basic or with back up (Z)

Ordering Information

To order state model number followed by the desired designation letter codes:
For example: product with no back up (Basic), use 6580R-TB
or product with back up feature, use 6580R-TBZ
where TB stands for twin engine and black body finish

INSTALLATION DIMENSIONS MODEL 6580R

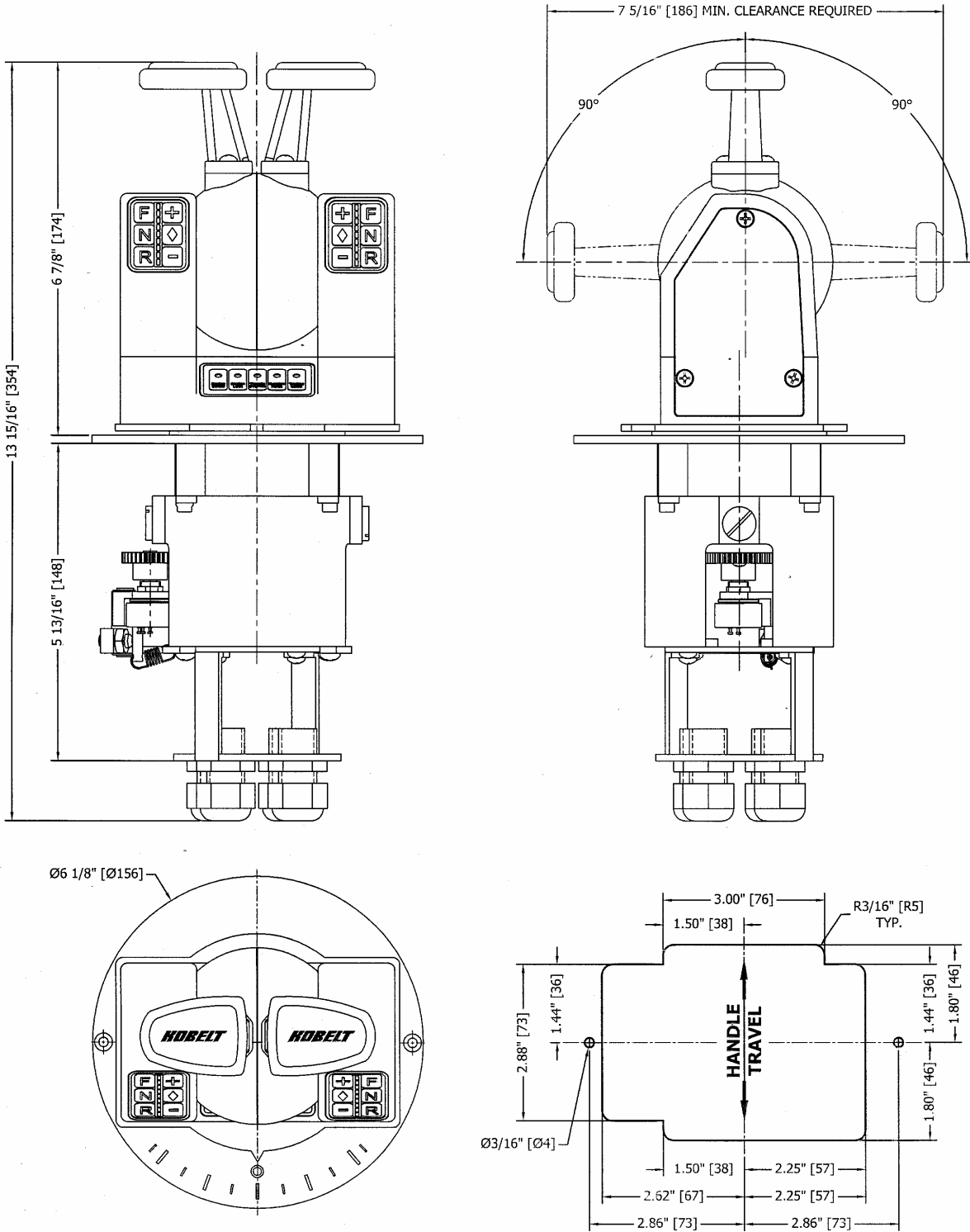

Data displayed are for information only and subject to change without notice

PARTS LIST

Item	Qty	P/N	Description	Item	Qty	P/N	Description
1	1	6580-0002	Base housing	30	2	YPB-3232	Gear
2	1	6580-0003L	Left housing	31	1	YP-3296	Gear
3	1	6580-0003R	Right housing	32	1	2009-0011	Detent
4	1	6580-0004L	Dome housing left	33	2	6580-0021	Detent
5	1	6580-0004R	Dome housing right	34	2	6580-0022	Friction
6	1	6580-0005L	Left housing cover	35	1	2542-0008	Friction pad
7	1	6580-0005R	Right housing cover	36	2	1202-0012	Spring
8	2	6580-0006	Pot holder bracket	37	2	1201-0227	Spring
9	1	6580-0007	PCB support	38	1	1201-0002	Spring
10	2	6580-0008	Cable holder	39	1	1201-0062	Spring
11	1	6580-0009L	Spring holder, left	40	2	1201-0228	Spring
12	1	6580-0009R	Spring holder, right	41	2	1025+0520	Snap ring pin
13	1	6580-0010	Bottom housing	42	12	1002-0706	Socket head cap screw
14	1	6580-0011	Rotation mounting housing	43	18	1012-0604	Pan head screw
15	1	6580-0012	Lower rotation housing	44	4	1012-0607	Pan head screw
16	1	6580-0013	Upper rotation housing	45	2	1012-0704	Pan head screw
17	1	6580-0014	Cable gland holder	46	6	1012-0706	Pan head screw
18	2	6580-0015	Lower pot holder	47	4	1012-0804	Pan head screw
19	2	6580-0016	Pot rubber holder	48	6	1009-0704	Flat head screw
20	1	6580-0017	Handle	49	2	1016-0602	Set screw
21	1	6580-0018	PCB, top	50	2	1016-1010	Set screw
22	1	6580-0019	PCB, lower	51	4	1016-1004	Set screw
23	1	Label-6580-L	Label, left	52	4	1029-1031	Snap ring
24	1	Label-6580-R	Label, right	53	2	1022-0210	Jam nut
25	1	Label-6580-M	Label, centre	54	4	6001-0249	Cable gland, ½" NPT
26	2	6580-0020	Detent plug	55	4	6639-0001	Pot washer
27	1	6652-0011L	Rubber insert, left	56	4	Pot nut	Pot nut
28	1	6652-0011R	Rubber insert, right	57	4	Pot LW	Pot lock washer
29	4	Pot-1	Potentiometer, 1K	58	2	6652-0016	Foam