

## MODEL 7096D 6" I.D. STEERING CYLINDER



### ORDERING INFORMATION

7096 - DU16 Cylinder with 16" stroke  
 7096 - DU20 Cylinder with 20" stroke  
 7096 - DU24 Cylinder with 24" stroke  
 7096 - DU30 Cylinder with 30" stroke  
 7096 - DU36 Cylinder with 36" stroke

Design pressure: 2000 psi (138 bar)

The 7096D cylinder is a further development of the 7096 model. The castings are all made in die cast silicon bronze. The steel barrel is micro-honed for fine finish. Piston rod is made of alloy steel and tie rods are of stainless steel. The spherical bearings on either end are heavy duty type and would hardly require replacement. Piston seals are made of polyurethane material for durability.

The piston rod uses "V-packing" seals and has an adjusting stop nut for stroke adjustment.

Since this cylinder is designed and only available in an unbalanced configuration, tandem cylinders are always required for all installations.

Rudder angle (RA) 35°

\*\* Torque is based on two cylinders at 2000 psi (138 bar)

**Torque		Stroke		Displacement		A		B †		C		D		E †	
lb-ft	kg-m	in.	mm	in <sup>3</sup>	cm <sup>3</sup>	in.	mm	in.	mm	in.	mm	in.	mm	in.	mm
94195	13023	16	406	792	12973	8	203	62.8	1594	13.95	354	12.7	322	57.5	1461
117735	16278	20	508	990	16217	10	254	68.8	1746	17.43	443	15.8	403	63.5	1613
141275	19532	24	610	1188	19460	12	305	74.8	1899	20.92	531	19.0	483	69.5	1765
176575	24413	30	762	1484	24325	15	381	83.8	2127	26.15	664	23.8	604	78.5	1994
211875	29293	36	914	1781	29190	18	457	92.8	2356	31.38	797	28.5	725	87.5	2223

Rudder angle (RA) 45°

**Torque		Stroke		Displacement		A		B †		C		D		E †	
lb-ft	kg-m	in.	mm	in <sup>3</sup>	cm <sup>3</sup>	in.	mm	in.	mm	in.	mm	in.	mm	in.	mm
65945	9117	16	406	792	12973	8	203	62.8	1594	11.31	287	9.7	245	57.5	1461
82420	11395	20	508	990	16217	10	254	68.8	1746	14.14	359	12.1	307	63.5	1613
98890	13673	24	610	1188	19460	12	305	74.8	1899	16.97	431	14.5	368	69.5	1765
123595	17088	30	762	1484	24325	15	381	83.8	2127	21.21	539	18.1	460	78.5	1994
148295	20503	36	914	1781	29190	18	457	92.8	2356	25.46	647	21.7	552	87.5	2223

NOTE † when order without adjusting stop nut, dimensions "B" and "E" can be reduced by 3½ inches (89 mm)

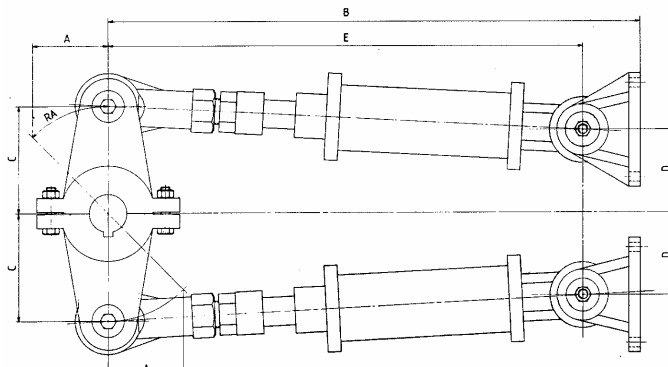

# DIAGRAM AND PARTS LIST MODEL 7096D

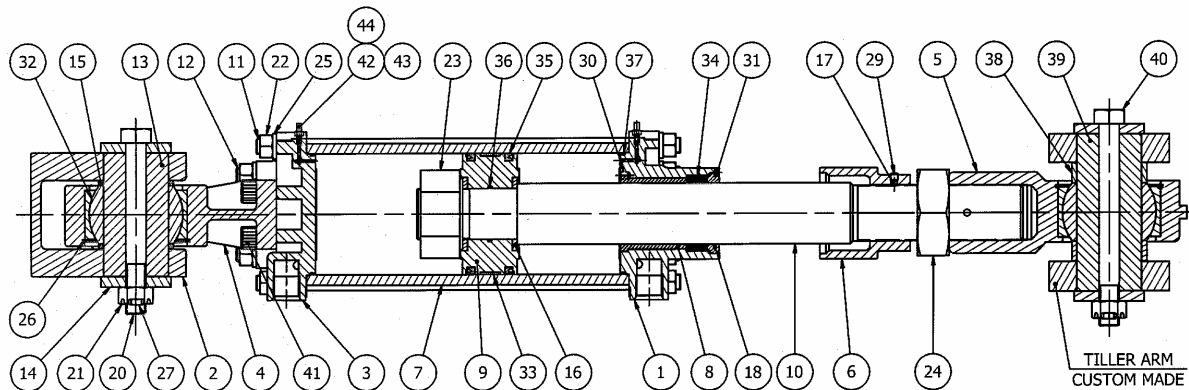
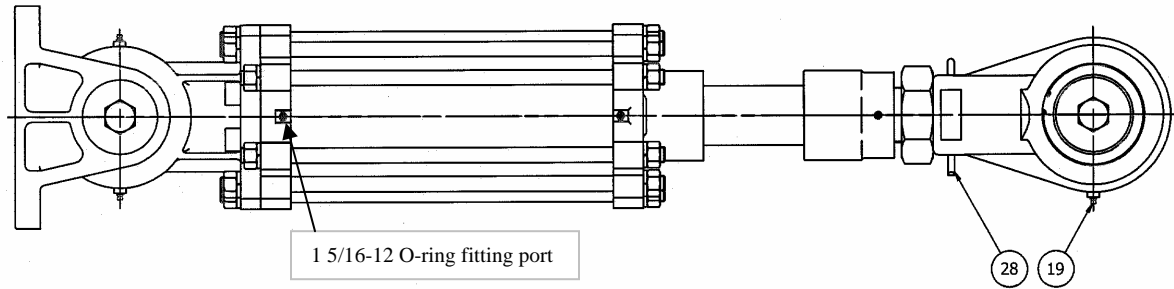

Item	Qty	Part No.	Description	Item	Qty	Part No.	Description
1	1	7096D-0001	Front end cap	23	1	7096-0022	Piston retaining nut
2	1	7096D-0002	Foot	24	1	1041-22275	Jam nut
3	1	7096D-0003	Rear end cap #1	25	20	1023-0318	Lock washer
4	1	7096D-0003B	Rear end cap #2	26	2	1029-3500	Retaining ring
5	1	7096D-0004	Rod end	27	2	1026-0832	Cotter pin
6	1	7095D-0005	Stop nut	28	1	1026-1260	Cotter pin
7	1	7096D-0006	Tube	29	2	1016-1206	Set screw
8	1	7096D-0007	Bushing	30	4	1016-1208	Set screw
9	1	7096D-0008	Piston	31	1	1016-1004	Set screw
10	1	7096D-0009	Piston rod	32	2	7096-8220	Spherical bearing
11	4	7096D-0010	Tie rod (short)	33	1	7096-0032	Wear ring
12	6	7096D-0011	Tie rod (long)	34	1	7096-0033	"V" packing
13	1	7096D-0012	Rear bearing sleeve	35	2	1102-2045	"U" cup
14	4	7096-0013	Sleeve retainer	36	1	1101-0230	"O" cup
15	2	7096-0014	Rear spacer	37	2	1101-0256	"O" ring
16	2	7096-0016	Piston washer	38	2	7096-0037	Front bearing spacer
17	2	7096D-0017	Friction pad	39	1	7096-0038	Front bearing sleeve
18	1	7096D-0018	Packing nut	40	1	1041-011610	Hex bolt, 10"
19	3	1501-0302	Grease nipple	41	4	1002-1832	Socket cap screw
20	1	1041-01169	Hex bolt, 9"	42	2	7094D-0015	Bleeder block
21	2	1041-31100	Castle nut	43	2	7040-0011	Bleeder screw
22	20	1022-0167	Hex nut	44	2	1301-0005	Ball

Some items are not shown on diagrams

Data shown are for information only and subject to change without prior notice.

