



GENERAL INSTALLATION AND ADJUSTMENT INSTRUCTIONS FOR VARIABLE PRESSURE CONTROL HEADS

Before making the cut-out for the control head on a control panel, it is important to consider the surrounding control equipment on the surface of the control panel as well as accessibility beneath the control panel for the installation of pneumatic tubing and possible adjustment or removal of the control valves.

It is important that all control heads are installed on a flat, smooth and solid surface. Bolting the control head frame onto an uneven surface will cause deformation of the main frame which in turn will result in binding of the control handle shaft in the bearing sections. In order to obtain a water tight joint between the control head and the mounting surface, a small amount of silicon or a thin gasket should be used between the two surfaces.

During installation, the control head should be kept clean and free from sawdust, metal chips and dirt as this could interfere with the longevity of the control head. The fittings on the control head must be clean and installed with a pipe sealant (Teflon tape is not recommended). Over-tightening of the pipe fittings could result in splitting of the control head castings.

The exhaust ports on our three- and four-way valves are provided with a pipe threads. The exhaust air can be piped away from the operator stand if so desired. The exhaust ports on our compensating pressure regulating valves are not threaded. A restriction at this port could cause the valve to hammer when the control air pressure is released to atmosphere. It is therefore best to leave the exhaust port unrestricted and not covered with any objects.

Tubing sizes are specified in our system drawings. Please take note of this. It is of extreme importance to keep the tubing free of foreign matter since dirt in the valves could cause leakage or inaccuracy. The control head shafts, pins, and rollers should be lubricated periodically with a good quality oil or grease.

All Kobelt control heads are equipped with adjustable detents and/or frictions which can be adjusted to the operators' requirements in the field.

The drawings on next page show locations of all adjusting screws which will affect the setting of the control head.

Adjustment No. 1 – This set screw can be adjusted to preload a valve to a minimum starting pressure.

Adjustment No. 2 – This set screw must be adjusted in conjunction with the adjusting screw at the bottom (adjustment no. 1). If the pressure range needs to be increased, the screw can be turned downwards towards the valve. If the valve responds too slowly to mechanical movements the slack can also be taken up with the set screw (adjustment no. 1).

Adjustment No. 3 – These two screws with jam nuts provide maximum handle travel stop which will result in a maximum output pressure limitation. For example, if adjustment No. 1 and 2 have been correctly made to establish a minimum pressure, the maximum pressure can now be set with these stop screws. Various springs are available as indicated in our product sheets to provide pressure ranges from 60-120 psi. Adjustment screw No. 3 should only be used for minor pressure adjustments.

Adjustment No. 4 – Adjustable nylon friction with spring and set screw. The set screw can be set to obtain the required drag on the handle to avoid creeping.

Adjustment No. 5 – Adjustable detent with stainless steel plunger, spring and set screw. This adjustment can be set to provide the required feel of the detent (roller for 2570 series).

Adjustment No. 6 – These adjusting screws should be adjusted so that one half the travel of the valve plunger will provide closing of the exhaust and the other half of the travel will open the valve to supply air to the clutch control circuit.

Adjustment No. 7 – Eccentric adjustment for the throttle cam. This adjustment provides an up and down motion for the roller contacting the main control cam and will permit adjustments of equal starting pressure in both gear engage positions. (Applies to 2540 series only).

Adjustment No. 8 – Provides supply flow control and therefore governs the volume of air to the clutch control circuit without affecting the exhaust capacity.

Adjustment No. 9 – On the 2570 series, will provide infinite adjustment of the cams controlling the pressure. Assembly screws holding the cam to the main drive spider hub must be loosened slightly. This will permit the cams to be altered, which will result in a change of mechanical movement of the pressure compensating valve leading to a change of output pressure. Several springs are available to assist in selecting the proper pressure range.

Adjustment No. 10 – Slidable adjustment for throttle arm. By sliding the roller link within the slots provided, the starting control pressure can be equalized in both directions.

It is important to assure that all screws, bolts and nuts are securely tightened.

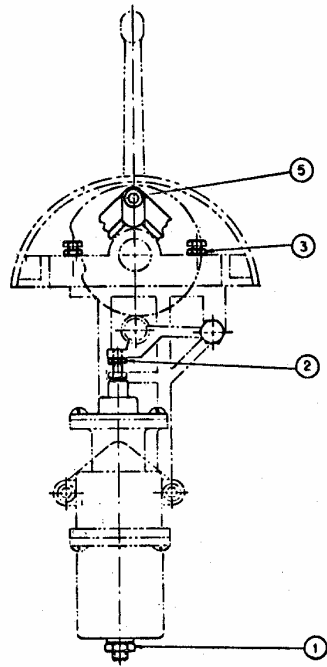

**INSTALLATION AND ADJUSTMENT
INSTRUCTIONS FOR VARIABLE PRESSURE
CONTROL HEAD 2542**

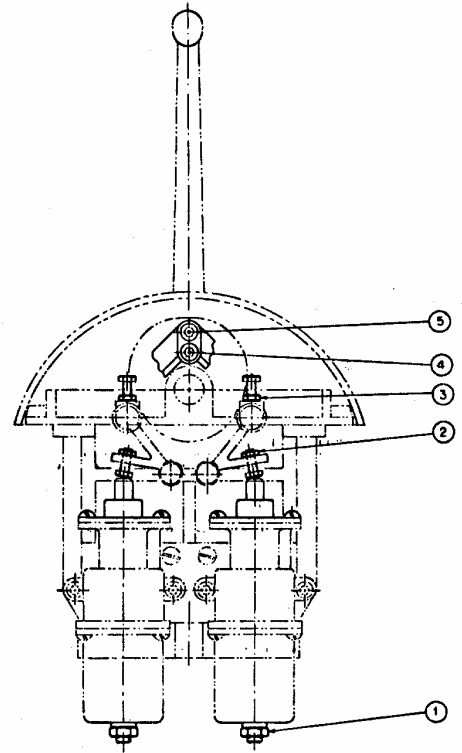

**INSTALLATION AND ADJUSTMENT
INSTRUCTIONS FOR VARIABLE
PRESSURE CONTROL HEADS
2543 - 2546 - 2547**

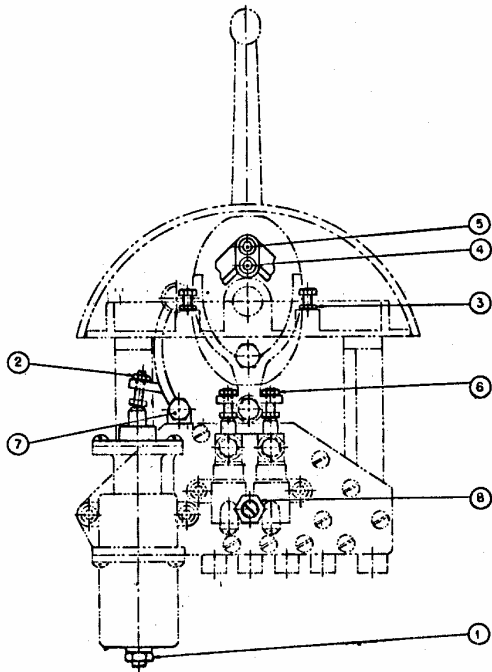

**INSTALLATION AND ADJUSTMENT
INSTRUCTIONS FOR VARIABLE
PRESSURE CONTROL HEADS
2544 - 2545 - 2543**

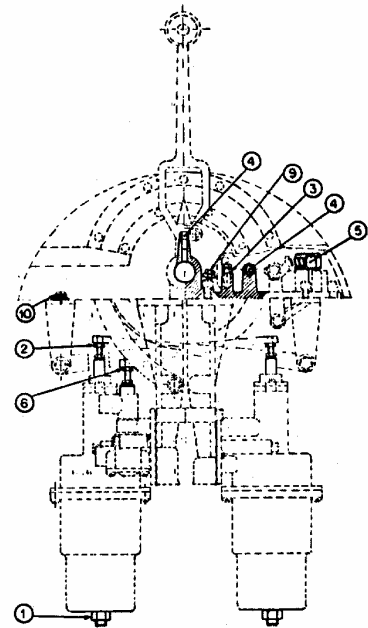

**INSTALLATION AND ADJUSTMENT
INSTRUCTIONS FOR VARIABLE
PRESSURE HEADS
2571-2572-2573-2574-2575-
2576-2577-78-79**