

KOBELT

7171 Full Follow Up (FFU) Control Lever

Owner's Operation, Installation & Maintenance Manual



March 2019

Kobelt Manufacturing Co. Ltd.

TABLE OF CONTENTS

1	Introduction	4
1.1	Contact	4
1.2	Safety	4
2	Product Description	6
2.1	Technical Data	6
3	Installation	7
3.1	Mechanical	7
3.2	Electrical	7
4	Commissioning	11
4.1	Electrical Check	11
4.2	Functional Test	11
5	Operation	12
6	Maintenance	13
6.1	Preventative Maintenance.....	13
6.2	Recommended Spare Parts.....	13
7	Troubleshooting	14
8	Warranty	15

1 INTRODUCTION

1.1 CONTACT

Kobelt Manufacturing Co. Ltd.
8238 129th Street
Surrey, British Columbia
Canada, V3W 0A6

Sales Tel: +1-604-572-3935
Fax: +1-604-590-8313
Email: sales@kobelt.com
Website: www.kobelt.com



This document is intended to clearly present comprehensive product data and provide technical information to assist the end user in design applications. Kobelt reserves the right, without notice, to change the design, or construction, of any products and to discontinue or limit distribution of any products. Kobelt also reserves the right to change, or update, without notice, any technical information contained within this document.

Kobelt recommends that customers visit our website to check for updates to this Manual. Once a product has been selected for use, it should be tested by the user to ensure proper function in all possible applications. For further instructions, please contact our distributors or visit our website.

1.2 SAFETY

1.2.1 Safety Alerts

Throughout this manual, the following symbols, and their accompanying explanation, are used to alert the user to special instructions concerning a service or operation that may be hazardous if performed incorrectly or carelessly. The associated risk levels are stated below.



 DANGER	This symbol indicates an imminently hazardous situation which, if not avoided, will result in death or serious injury.
 WARNING	This symbol indicates a potentially hazardous situation which, if not avoided, could result in death or serious injury.
 CAUTION	This symbol indicates a hazardous situation, which if not avoided, could result in minor or moderate injury.
NOTICE	This symbol informs the reader of events not related to personal injury but which there is a risk of damage to property or equipment.
SAFETY INSTRUCTIONS	This symbol informs the reader of safety-related instructions or procedures.

1.2.2 Notice to Installer

Disregarding the following safety measures can result in an accident causing severe injury to personnel and damage to material assets.

- Only use the product as directed in this manual.
- Never put the product into service if there is evidence of visible damage.
- Never put the product into service before fully completing installation and commissioning.
- Do not carry out any modifications to the product.
- Only use authentic Kobelt spare parts.
- Observe all local regulations, directives and laws during the installation of this product.
- All installation, commissioning, and maintenance work must only be conducted by qualified personnel. (For the purpose of this manual, qualified personnel are persons who are familiar with the assembly, installation, commissioning, and operation of the product and who have the qualifications necessary for their occupation.)
- Observe all specifications in this manual. If these guidelines are not followed and damage occurs, the warranty will be voided.

1.2.3 Product Hazards

 WARNING	Disconnect Power: Turn off power at distribution panel before beginning installation to protect installer from electrical hazards.
 CAUTION	Voltage and Current Compatibility: Confirm that the power source is compatible with the maximum voltage and current ratings of is product variant. Failure to do so could result in damage or fire.

2 PRODUCT DESCRIPTION

The Kobelt 7171 Full Follow Up (FFU) Control Lever is used as an input to FFU electronic steering systems. The operator can maneuver the vessel by moving the lever port or starboard to adjust its internal potentiometer. The FFU Control Lever can be used for steering applications, other marine applications, or industrial installations.

The 7171 can be purchased with electrical switches at the far port and starboard extremes to handle Non-Follow Up (NFU) mode command signals to the on-board control system.

The 7171 is designed for indoor and outdoor installation with a robust die cast bronze and stainless steel construction to provide a long service life in a harsh marine environment. The standard configuration contains an elegant polished chrome jog handle and black surface finish complements vessel control stations. Optionally, the 7171 can be configured to contain a small wheel in place of the jog handle.



Figure 1: 7171 Overview Diagram

2.1 TECHNICAL DATA

Table 1: 7171 Technical Data

MODEL	7171 SERIES	
KOBELT P/N:	7171-P, 7171-PP	7171-B, 7171-SWB
ELECTRICAL SWITCH CONTACTS	--	Form A, NO (Normally Open) (per direction)
MAX. CONTACT VOLTAGE	--	250 VAC / 32 VDC
MAX. CONTACT CURRENT	--	10 A (per switch contact)
CONTROL POTENTIOMETER	Up to 2x 1kΩ	
MAX. POTENTIOMETER POWER	1 W	
OPERATING TEMPERATURE	-13°F ... 158°F [-25°C ... 70°C]	
PRODUCT WEIGHT	5 lbs [2.2 kg]	

3 INSTALLATION

3.1 MECHANICAL

Ideally, the Full Follow Up (FFU) Control Lever should be mounted in a central location at each station on-board the vessel to control steering operation.

- Within 6 feet [1.8 m] of electrical junction box.
- Placed on horizontal or angled dash surface.
- Placed as to protect external electrical cables from damage.

The FFU Control Lever is equipped with (4) four clearance holes for #10 (M5) screws or bolts through the top surface for direct mounting to the dash. Ensure the unit is securely fastened to a suitable surface.

3.2 ELECTRICAL

The FFU Control Lever has 6 foot [1.8 m] long 3C/18 cables for external connections. Connect them to an electrical junction box and the electronic or power hydraulic steering system interface as required.

The product's 3C/18 electrical cables contains the following wires and related functions:

Table 2: 7171 Wire Connections – Potentiometer 1

7171 - Potentiometer 1				
Wire #	Wire Name	Colour	Gauge	Function
1	POT+	White	18AWG	FFU potentiometer 1 power supply connection.
2	POT WIPER	Green	18AWG	FFU potentiometer 1 signal connection.
3	POT-	Black	18AWG	FFU potentiometer 1 ground connection.

Table 3: 7171 Wire Connections – Potentiometer 2 (Dual Pot Configurations Only)

7171 - Potentiometer 2				
Wire #	Wire Name	Colour	Gauge	Function
1	POT+	White	18AWG	FFU potentiometer 2 power supply connection.
2	POT WIPER	Green	18AWG	FFU potentiometer 2 signal connection.
3	POT-	Black	18AWG	FFU potentiometer 2 ground connection.

Table 4: 7171 Wire Connections - Switches ('B' Configurations Only)

7171 - Switches				
Wire #	Wire Name	Colour	Gauge	Function
1	SWA-NO	Black	18AWG	Connects to COM when Switch A is activated.
2	SWB-NO	White	18AWG	Connects to COM when Switch B is activated.
3	COM-AB	Green	18AWG	COM connection.

The cable penetration locations shown in Figure 2 and the internal wiring connections are shown in Figure 3. Note that the internal wiring connections may differ depending on the configuration variant ordered. For example, not all variants contain two potentiometers or internal switches.

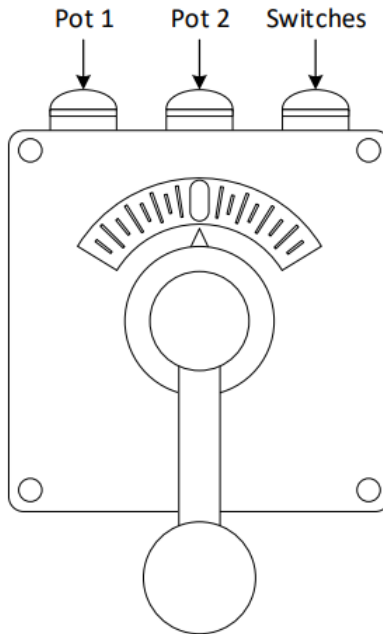

Figure 2: 7171 Cable Penetration Location

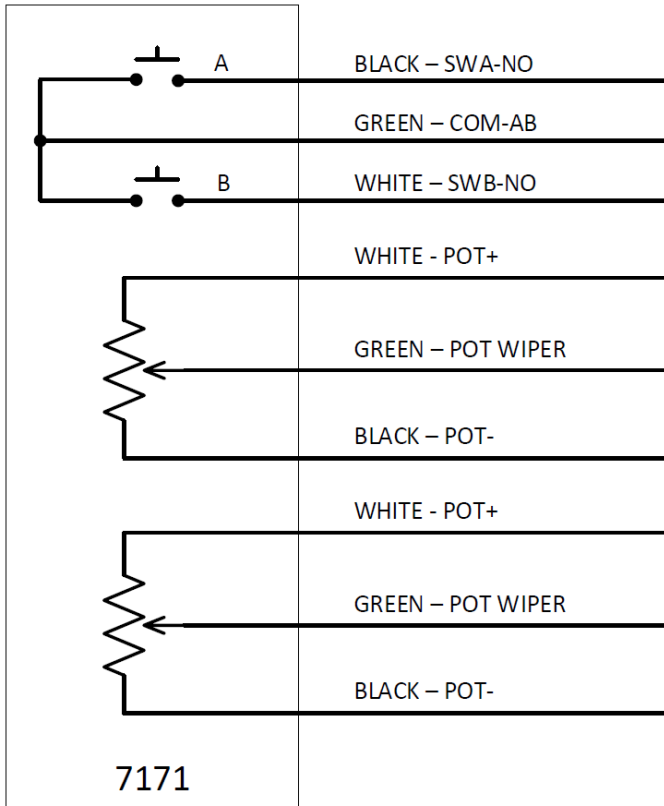

Figure 3: 7171 Internal Wiring Diagram

NOTICE

Note that the secondary potentiometer and switches may not be present on all configurations of this product. Refer to product code key for definition of internal components.

The operating direction of the Potentiometer in relation to the Full Follow Up Control Lever handle is shown in Figure 4.

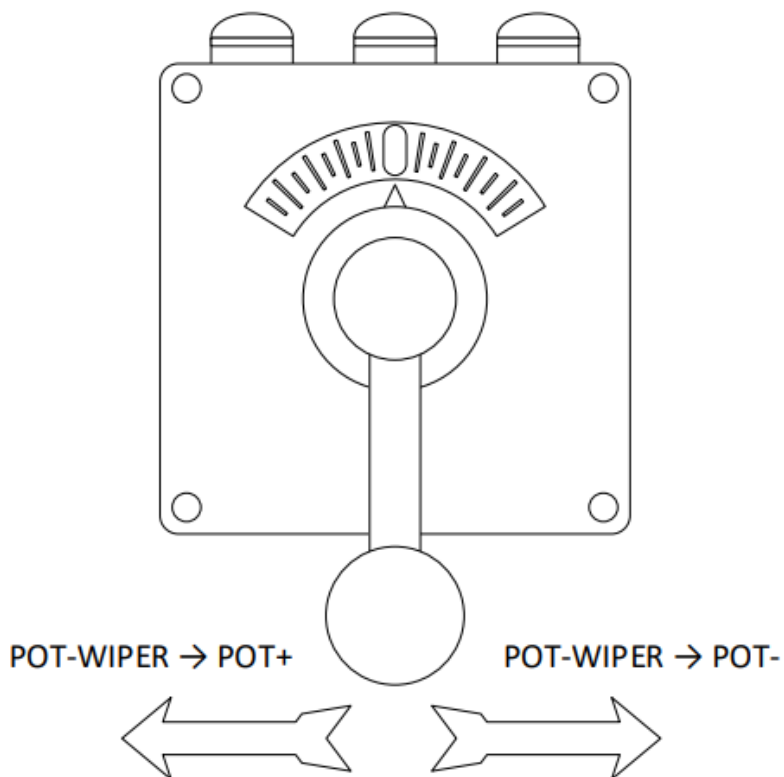

Figure 4: 7171 Potentiometer Direction Diagram

4 COMMISSIONING

4.1 ELECTRICAL CHECK



CAUTION

Ensure that the rear cover is installed and secured before powering on the 7171.

Confirm that the electrical connections to the 7171 have been made correctly and correspond to the requirements of your system installation.

4.2 FUNCTIONAL TEST



CAUTION

The Functional Test should be carried out while the vessel is still at dock and before it is taken out to sea after installation has been completed.

A complete functional test should be performed on the system that the Full Follow Up Control Lever has been installed within before entering operational use.

5 OPERATION

The Kobelt 7171 Full Follow Up (FFU) Control Lever contains one or two potentiometers and optionally a set of switches for each direction of travel. Operating the FFU Control Lever causes the steering gear to move in the desired direction. When the lever is released it stays at the set position and does not spring back to centre.

Operating the lever in either Port and Starboard, or Left and Right, directions commands motion in the system it is controlling.

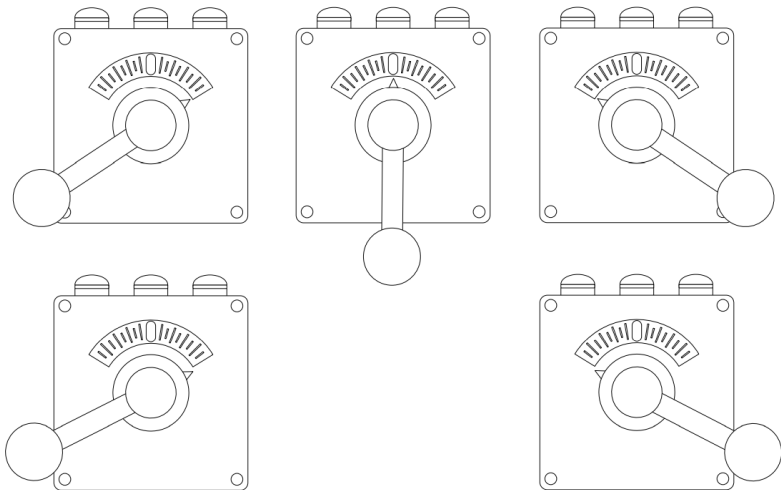

Figure 5: 7171 Positions of Operation, SWITCH LEFT, FFU LEFT, CENTRE, FFU RIGHT and SWITCH RIGHT

CAUTION

Ensure that the FFU Jog Lever is set to within a few degrees of the current rudder angle before switching into FFU mode. Not doing so will result in immediate movement of the rudder to the commanded position.

6 MAINTENANCE

6.1 PREVENTATIVE MAINTENANCE

- Quarterly (4 times per year)
 - Visually inspect wire and cable insulation for splits or damage.
 - Ensure there is no visible corrosion on the unit.
 - Conform cable glands are secured to cables.

6.2 RECOMMENDED SPARE PARTS

No spare parts are recommended for this unit.

NOTICE

It is recommended that any required service work on a Kobelt unit be performed by a factory authorized service representative. Please contact the nearest Kobelt authorized distributor for assistance.

7 TROUBLESHOOTING

If you encounter problems with the operation of your product, please refer to the troubleshooting suggestions before contacting Kobelt for assistance. If the steps below do not resolve your issue, please reach out either Kobelt directly or our Dealers in your area.

Table 5: Common Solutions

Problem (Issue encountered)	Cause (What it means)	Corrective Action (What to do)
Full Follow Up Control Lever action is reversed.	Wiring is backwards.	Swap the POT+ and POT- output wires to their respective potentiometer and system connections.
Full Follow Up Control Lever does not move rudder at all.	The rest of the system isn't hooked up correctly.	Check system wiring. Confirm wiring to Full Follow Up Control Lever.
	Broken potentiometer or contact.	Use a multi-meter to monitor the resistance of the wiring between potentiometer contacts. Check for normal operation of the potentiometer by measuring the connection while moving the Full Follow Up Control Lever. Check potentiometer directions. Replace any damaged potentiometers.
	Wiring is wrong.	Check wiring. Refer to system design drawing for proper wiring.

8 WARRANTY

Kobel Manufacturing Co. Ltd. ("Kobel") warrants the Products and Parts manufactured by Kobel to be free from defects in workmanship or material and that said products are designed mechanically and functionally to perform to specifications.

This warranty is effective providing:

- The equipment is used within the intended operating conditions and in accordance with Kobel recommendations
- The equipment is installed according to equipment diagrams, specifications and recommendations which Kobel has provided

This warranty becomes invalid if the factory supplied serial number has been removed or altered on the product. This warranty does not cover cosmetic damage or damage caused by an act of God, accident, misuse, abuse, negligence or modification of any part of the product. This warranty does not cover damage due to improper operation or maintenance, connection to inappropriate equipment or attempted repair by anyone other than an authorized Kobel representative.

Upon identification of a potential issue or defect with a Kobel Product or Part, the Warranty Applicant ("Applicant") must immediately contact Kobel and describe the issue in writing, by letter, fax, email or other electronic conveyance. Kobel will then assess the cause of the defect and determine warranty applicability and appropriate remediation.

If any part is found to be defective, Kobel will replace said part FOB the Kobel factory provided that any such defective part is returned by the Buyer with freight and applicable forwarding charges prepaid by the Buyer. Kobel's sole obligation to the Applicant will be to repair or replace the defective part with same or similar product, to a maximum value of the list price of the product or part. The Kobel warranty does not cover labour charges, travel or any other associated expenses.

All Products and Parts manufactured by Kobel, are subject to a warranty against manufacturer's defects in materials or workmanship for a period of two (2) years from the date of purchase.

Kobel will be responsible for all Products or Parts sold by Kobel but manufactured by 3rd party manufacturing companies. However, these products and parts are subject to applicable 3rd party warranties and may not be the same as the Kobel warranty.

KOBELT

Kobelt Manufacturing Co. Ltd.

8238 129th Street
Surrey, British Columbia,
Canada, V3W 0A6

Sales Tel: +1-604-572-3935

Fax: +1-604-590-8313

Email: sales@kobelt.com

Website: www.kobelt.com

Made in Canada / Printed in Canada