

KOBELT

MANUFACTURING COMPANY LIMITED
8238 - 129th Street
Surrey, B.C. Canada V3W 0A6
Telephone: (604) 572-3935
Fax: (604) 580-8313
<http://www.kobelt.com>

INSTALLATION INSTRUCTION MANUAL

FOR

KOBELT PNEUMATIC SYSTEMS



NOTES ON WARRANTY

Kobel Manufacturing provides installation and maintenance instructions for its products. If these guidelines are not followed, the warranty will be voided.

If our instructions are followed during installation and maintenance, the performance of our products will prove to be most satisfactory. There is nothing like a satisfied customer.

For further instructions, please contact our distributors or visit our website at <http://www.kobel.com>

Table of Contents

| | <u>Page</u> |
|--|-------------|
| 1. Basic Operating Principle of Kobelt Pneumatic Parts | 3 – 10 |
| 2. Basic Pneumatic Installation Instructions on Ships | 11 – 13 |
| 3. Troubleshooting Guide for Basic Pneumatic Control System | 14 – 15 |
| 4. Installation and Adjustment Instruction for Variable Pressure Control Head | 16 – 17 |
| 5. Adjustment Instruction for Constant Timing Control Panel | 18 – 19 |
| 6. Adjustment Instruction for Variable Timing Control Panel | 20 – 23 |
| 7. Overriding & Interlocked Throttle | 24 – 25 |
| 8. Pneumatic Maintenance | 26 |
| 9. Periodic Inspection | 27 |



BASIC OPERATING PRINCIPLES OF KOBELT PNEUMATIC COMPONENTS

The purpose of this section is to remove the mystery of how pneumatic components function. We feel that this will be of great benefit to all personnel involved with Kobelt pneumatic control components. All the illustrations show only the most essential parts in order to provide a better and clearer view of the basic operating principles.

The color scheme chosen is to show the pressure level in individual sections. The darker gray denotes a higher pressure and the lighter color denotes a lower pressure.

Some control systems and machinery packages can be very complex in their design. However, if the basic principles of operation for each component are understood, any person with some mechanical aptitude should be able to work their way through the system and provide a clear overview for troubleshooting and maintenance. In many instances a failure in control response could be due to a malfunction in associated equipment and a good service technician can then point out to the customer precisely where the problem lies.

3-WAY AND 4-WAY VALVES

Kobelco control valves and pneumatic devices are all designed around the poppet valve principle. The poppet valve is the least sensitive to dirt, leakage and sticking. Since our primary aim is to provide a trouble free system, we have chosen this type of valve.

3-Way Valve

The 3-way valve illustrated in Figure 1 is shown in the closed position with the control stem outward. The air entering the "IN" port is trapped behind the seat and the poppet and has no way of going past these two parts. Any accumulated air in the "OUT" line is allowed to exhaust via the hollow stem through the "EXHAUST" port to atmosphere.

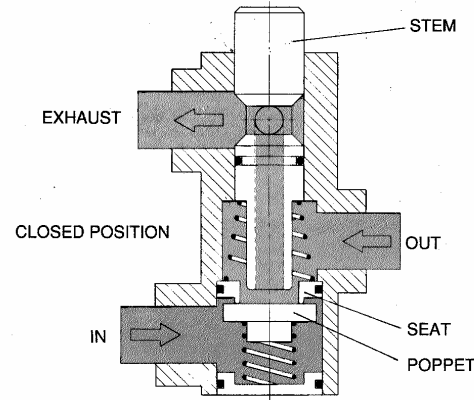

FIGURE 1

The 3-way valve illustrated in Fig. 2 is shown with the stem moved inward to an open position and permits air flow from the "IN" port to the "OUT" port therefore energizing the actuator attached to this valve. The hollow stem is seated against the inner portion of the poppet and does not permit exhaust of air to atmosphere while the valve is in this position.

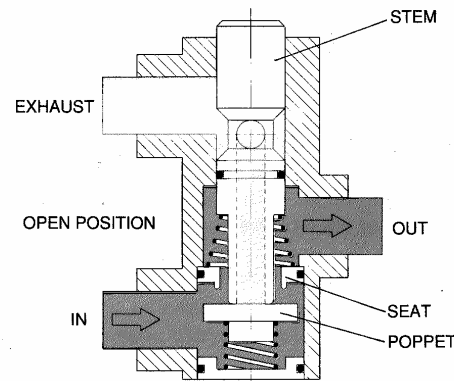

FIGURE 2

4-Way Valve

The Kobelco 4-way valve consists of two 3-way valves combined into one housing with a common supply. These valves are not pressure compensating but, are intended strictly for on/off use.

The poppet in this type of valves should provide at least 10-15 years of quality service. The "O" ring on the stem should normally last a minimum of 6 years. After dismantling this valve, be sure to re-install all components properly (refer to product sheet). It is important that no foreign matter enters the system or the valve.

SHUTTLE VALVE

The purpose of the Shuttle Valve is to provide a common resulting line from two different sources of supply. For example if two 3-way valves are used to control a common cylinder and these two units are inter-connected with an ordinary Tee fitting, the control air pressure from one control could exhaust out from the exhaust port of the second control. Consequently a device such as a 2-way check valve or Shuttle Valve is required to prevent this from happening.

Figure 1 shows the control air pressure coming in from "LINE 1" and going out the "RESULTING LINE". The air pressure causes the shuttle to slide towards "LINE 2" and seal against the "RUBBER WASHER" thus preventing air from leaking out through the device attached at the end of Line two.

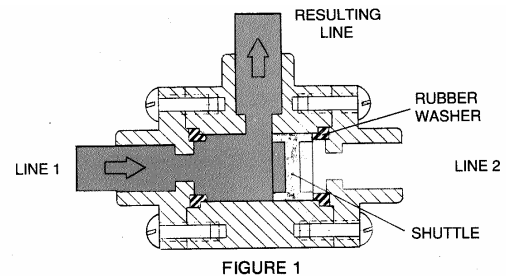

FIGURE 1

Figure 2 shows the Shuttle Valve with full line pressure entering "LINE 2" and partial line pressure in "LINE 1". The higher air pressure in "LINE 2" is capable of moving the shuttle against the "RUBBER WASHER" thus preventing air from leaking past this seal into "LINE 1".

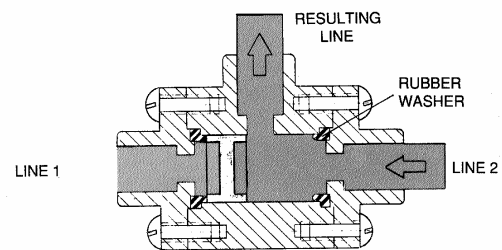

FIGURE 2

Figure 3 shows an equal air pressure coming from two sources of supply and also going downstream via a "RESULTING LINE". Please note that the cylindrical bore for the resulting line is opened up to allow air passage with the shuttle sitting mid position (Model 3010).

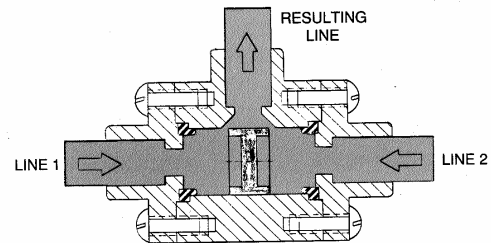

FIGURE 3

However, with a regular Shuttle Valve such as a model 3009 (without the internal relief on either side), the shuttle would seal the port of the resulting line prohibiting air flow to the controlled device.

An important factor to remember is that **the supply line to a shuttle valve should never be plugged**. Plugging of a supply line (line 1 or 2) will result in a gradual accumulation of pressure which will eventually reach maximum line pressure. This will render the Shuttle Valve inoperative and cause loss of control.

The Shuttle Valve should **always be installed with the cylindrical bore in a horizontal position**. The rubber seals are the only parts that require replacement after approximately 6-10 years of use. If the system is kept clean no metal parts should ever be required.

QUICK RELEASE VALVE

The Quick Release Valve serves as a device in a control circuit for exhausting air without returning it to the original source of supply. The name itself defines its function very clearly. Its main purpose is to dump air quickly.

In Figure 1, the valve is illustrated with high pressure coming from the control device to the "IN" port. This is causing the outer rim of the diaphragm to deflect downward, pushing the spring and retainer plate down in the same direction, which will permit air flow to the "OUT" ports.

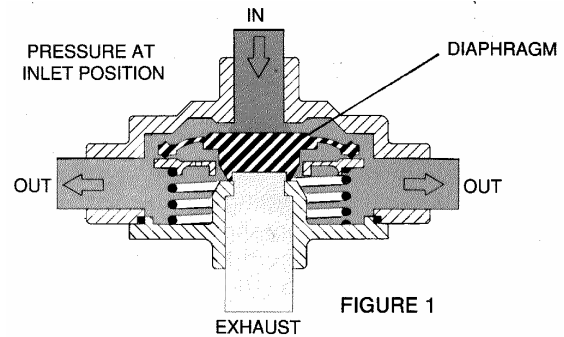

In the equilibrium position shown in Figure 2 the outgoing pressure is now equal to the supply pressure. The diaphragm is returned to its original position sealing against both the "EXHAUST" and the "SUPPLY" seat.

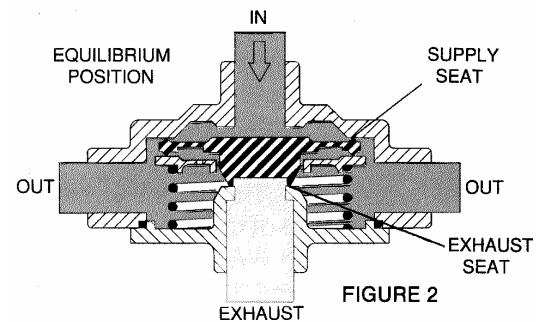

In Figure 3 the Quick Release Valve is shown with the supply pressure vented to atmosphere. The accumulated air in the system now forces the diaphragm against the "INNER SEAT" of the "IN" port, which permits venting of the system to atmosphere via the "EXHAUST" port of the Quick Release Valve.

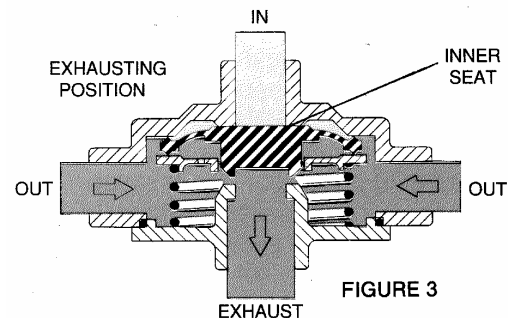

The Quick Release Valve as illustrated in Figure 2 shows its natural position. In this position the rubber diaphragm must make contact at the upper edges of the supply cavity and at the exhaust seat without deflecting the diaphragm in an upward position. There should be no clearance between the exhaust portion of the diaphragm and the Quick Release housing cap.

The Quick Release Valve should always be **installed with the exhaust port facing down** to avoid dirt entering the valve. The only replacement parts required in this valve is the diaphragm, which normally provides 6-10 years of trouble free service.

RELAY VALVE

The basic purpose of a Relay valve in pneumatic control circuitry is to provide interlocks and delays of various pneumatic actions. The pilot line, which is the control element of the relay, overcomes the adjustable spring setting to either open or close. It is important that the spring setting conforms to the requirements of the system. Setting a normally open relay valve spring too low will result in the valve remaining closed at all times. At the same time, setting a normally closed relay valve spring above the available air pressure will result in the valve not opening. A flow control valve used in conjunction with an accumulator tank will further assist the timing range of these adjustable relays.

It is recommended that the valve be mounted with the adjusting means at the top and the supply and outlet ports at the bottom.

The Relay Valve illustrated on this page is a normally open type. It is basically the same as a mechanically operated 3-way valve with its in, out and exhaust ports (as illustrated on 3-Way Valve section).

In Figure 1 the valve is shown in its open position with the spring forcing the stem down. This permits flow of air from the "IN" port to the "OUT" port. Air cannot escape out of the "EXHAUST" port since the lower part of the stem is sealed against the poppet.

Figure 2 illustrates the valve in its closed position. The pilot air pressure is accumulated under the diaphragm which causes the spring to compress and in turn retract the stem which causes the poppet to seat. This stops the flow of air from the supply to the valve. At the same time any accumulated air in the "OUT" line and attached components is permitted to enter the hollow stem and exhaust to atmosphere via the "EXHAUST" port.

It is important to remember that *the vent port must not be plugged* in order to allow the diaphragm to move without back pressure. The pressure setting screw on top of the valve will permit in-field fine adjustment of the valve pressure setting point. Several springs are available which will provide a complete range of pressure settings from 15 to 140 psi.

The synthetic rubber parts in all Kobelt Relay Valves should provide 6-10 years of service. When dismantling valves of this nature, it is important to *avoid dirt and foreign matter from entering the control system and valve.*

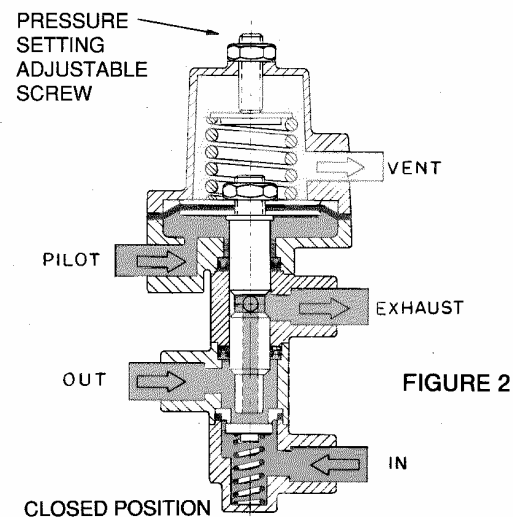
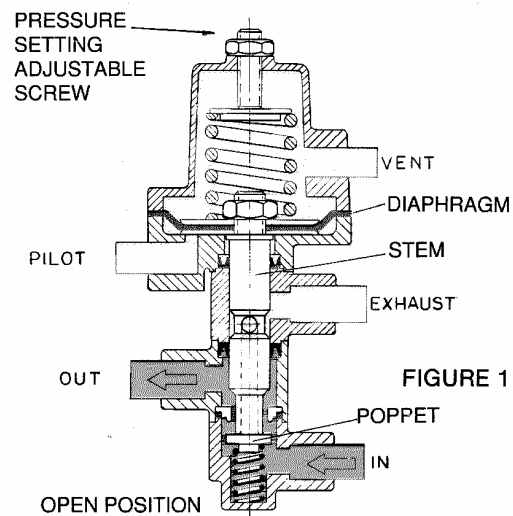

RELAY VALVE

The valve illustrated on this page is normally closed. It is basically the same as the valve shown on the preceding page but with function of the valve reversed.

Figure 1 shows the valve in its normally closed position with the spring pulling the diaphragm stem up which allows the valve stem to follow. This stops the flow of air through the valve and will permit all accumulated air in the "OUT" line to exhaust via the "EXHAUST" port.

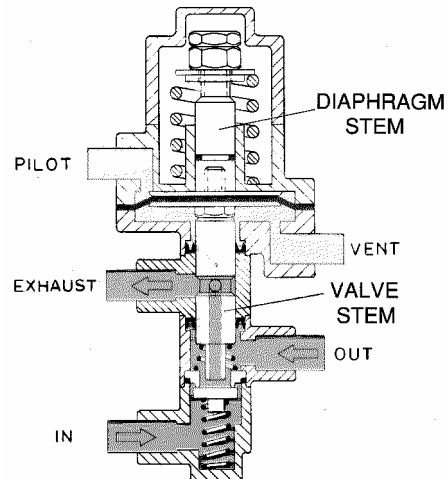

FIGURE 1

Figure 2 shows the valve with sufficient pilot pressure entering the diaphragm cavity to overcome the spring thus depressing the valve stem downward and permitting flow of air from the "IN" port to the "OUT" port. The "EXHAUST" port at this point is sealed.

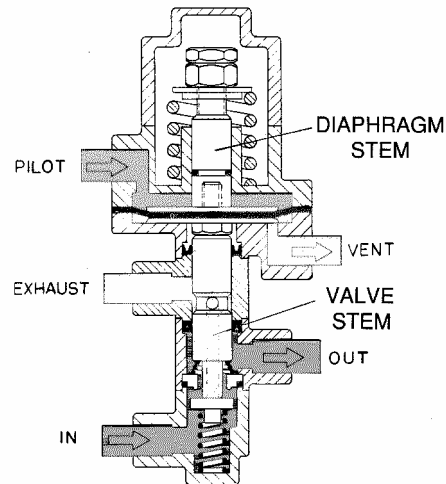

FIGURE 2

Figure 3 illustrates a normally open relay valve with two diaphragms. These relay valves are used for dual piloting and can be extremely useful in interlocking circuits. The reason for the two diaphragms is to avoid double deflection of the diaphragm which could result in premature failure. Also, in case of diaphragm failure, the pilot pressure cannot be cross-fed back into the system, since the spacer piece provides for venting to atmosphere.

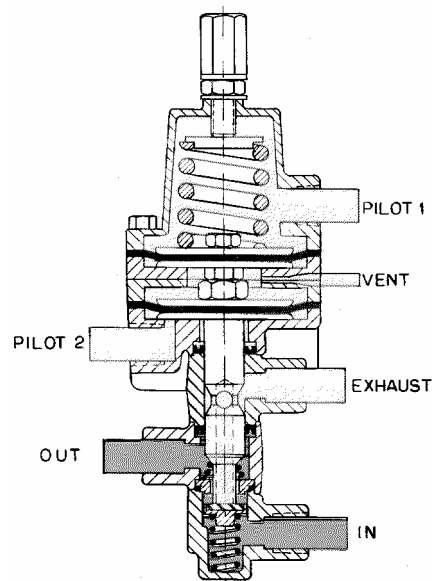

FIGURE 3

The basic operating principles of this valve are the same as the foregoing valves. It is also available in a normally closed version.

PRESSURE COMPENSATING REGULATOR VALVE

The purpose of the pressure compensating regulator is to provide an infinitely variable output pressure signal. There is a direct relation between the mechanical input stem position and the amount of accumulated air in the control system. The balance is obtained with air pressure against a reactor spring. The rolling diaphragm makes these valves very accurate due to the low friction.

The air pressure entering the "IN" port is held in check until the "STEM" is depressed downward (see Fig. 1). This downward movement will create an opening between the supply ball and the seat thus allowing air to flow to the "OUT" port (see Fig. 2). Air pressure goes to the "OUT" port and via the orifice to the piston chamber, then compresses the reactor spring at the bottom of the valve until such a point that both supply and exhaust valve balls are seated into their respective seats. This will cause an equilibrium point whereby no air flow will take place. Allowing the "STEM" to move upwards will cause the exhaust ball to lift itself from its respective seat and permit exhaust of air to atmosphere. This will allow the main reactor spring to push the seat upwards until the valve is in a balanced position again.

These valves are manufactured in three different pipe sizes, 1/8", 1/4" and 1/2" N.P.T. ***It is important to keep these valves free from dirt and foreign matter since the valve seat and the valve ball are quite sensitive to dirt.*** Caution should be taken to avoid dirt entering the pneumatic control system during installation and operation.

A filter in the supply line is essential. Steel and iron tubing are not recommended. This valve should operate for 6-10 years without problems. Only synthetic rubber parts and diaphragms will be required for overhaul.

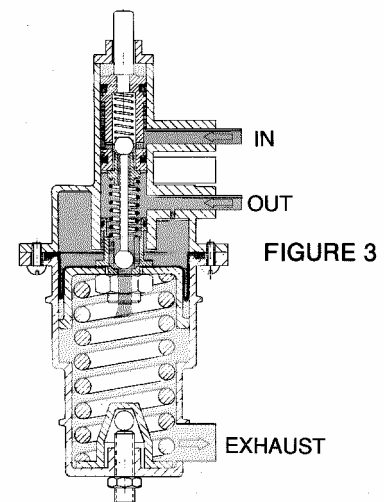
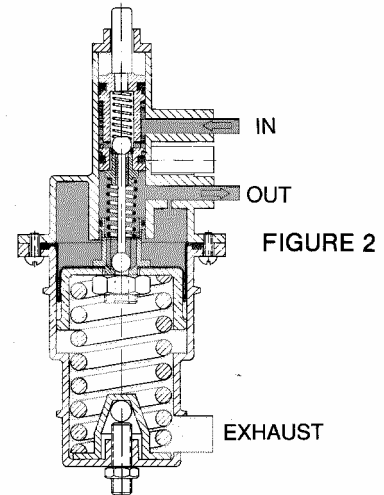
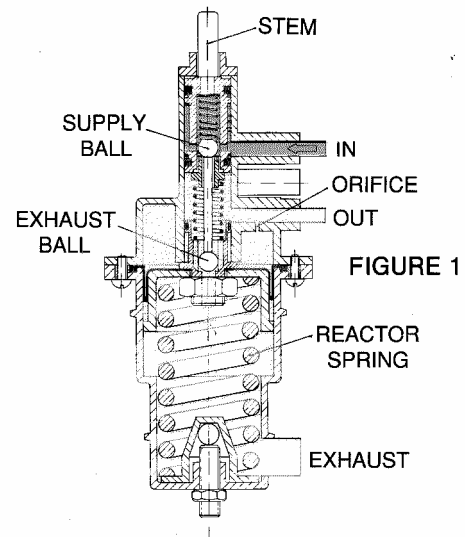

PNEUMATIC POSITIONERS

Single direction positioning units (Figures 1 and 2) are required for the control of engine speed, etc. Two direction control devices (Figures 3 and 4) are used for such applications such as variable delivery hydraulic pumps, controllable pitch propellers and many other applications where two direction positioning is required.

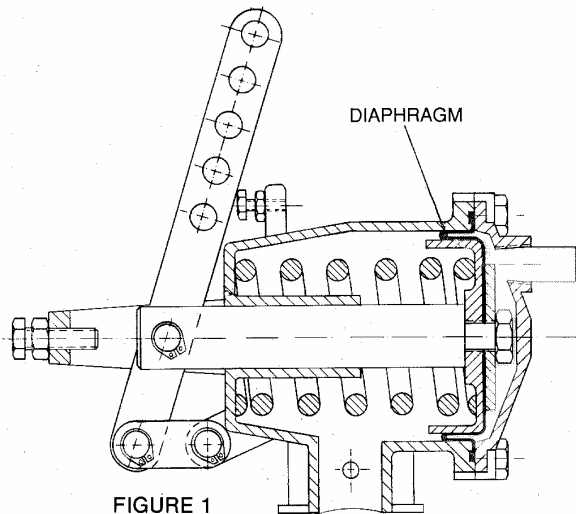
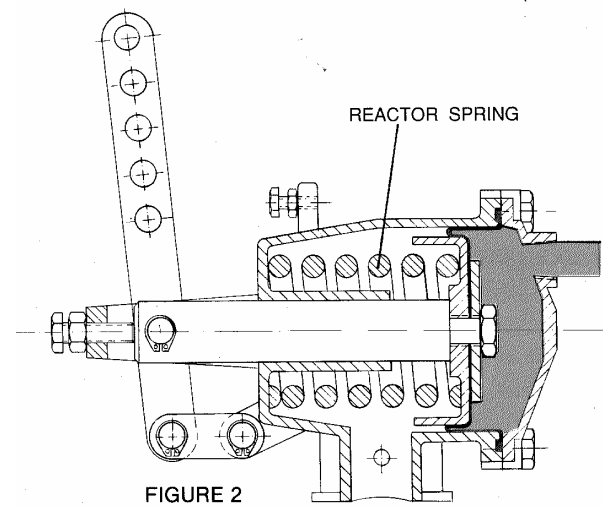

Figure 1 shows atmospheric pressure behind the spring and diaphragm assembly. The piston rod and output linkage are in their most retracted position.



In Figure 2, increasing the air pressure will cause a compression of the reactor spring, which in turn causes the piston rod and linkage to move outward proportionally to the input pressure.

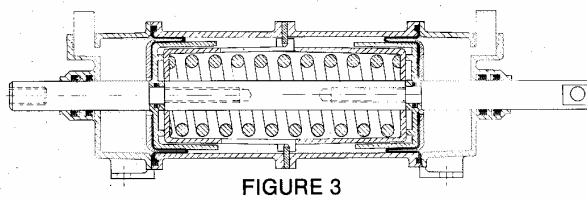

Figure 3 shows a positioning device in its neutral and relaxed position and atmospheric pressure at both ends of the cylinder.

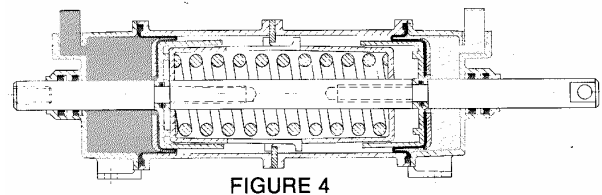

Figure 4 shows the cylinder with air pressure accumulated at the left hand side behind the diaphragm and piston assembly. This causes the piston rod to move to the right. The spring is retained by a spring housing which is caged behind a center ring. Again a rolling diaphragm and spring permits infinite positioning in both directions. In order to prevent premature damage to the diaphragm, it is recommended to maintain a 2-3 psi pressure at all times at both end of the cylinder.



BASIC PNEUMATIC PROPULSION CONTROL INSTALLATION INSTRUCTIONS FOR SHIPS

Location and Mounting of Components

It is important to first select the location for the control heads and to ensure that these units are installed in an area that is easily accessible. They should not interfere with any other moving projections or devices that could obstruct the accessibility of the control levers. The mounting surface for our controls must be smooth and flat. Details for cutout dimensions can be found on the individual product sheets.

The components on the engine must also be installed on solid brackets attached with bolts to the propulsion machinery. Badly designed bracketing can multiply basic engine vibration to a point where it can prematurely wear down control devices installed on propulsion packages. Vibrations of this nature are visually apparent and the bracketing should be reinforced or altered to avoid this from happening. Linkages connecting our control components to the governor, clutch and C.P. propeller must provide the correct stroke.

Engine timing panels must be located in the engine room and should be easily accessible for installation of the tubing and for timing adjustments. It is understood that no components on a ship are absolutely vibration-free, but timing panels again must be installed in such a way to avoid high frequency vibrations since this will prematurely damage the copper tubing. The timing panels must also be installed on a flat surface, and deformation of the panel or control box must be avoided.

Installing the Air Lines

The copper tubing connecting the components must be kept clean and free from dirt during installation. It is extremely important that the tubing size is used as per Kobelt Manufacturing's specifications. Failing to select the tubing as per our drawings may result in poor control response of the system for which Kobelt Manufacturing will not assume responsibility.

Teflon tape should not be used on pipe fittings. A liquid pipe sealant, applied at the end of the fitting, is preferable. Pipe fittings should not be over-tightened since the tapered thread can cause splitting of the control components. The table below indicates torque required for tightening tapered pipe fittings.

| | |
|-------------|----------|
| 1/8" N.P.T. | 10 ft-lb |
| 1/4" N.P.T. | 20 ft-lb |
| 3/8" N.P.T. | 30 ft-lb |
| 1/2" N.P.T. | 40 ft-lb |

A section of rubber hose must also be installed at the end of the copper tubing connecting to throttle and gear actuator. This is to take up the vibration and to avoid the transmission of electrolytic effect to the system. If a shipyard chooses to use hose for the complete installation on smaller ships, Kobelt Manufacturing has no objection to this providing that the inspection authorities accept the choice of hose material used.

The tubing sizes specified by Kobelt Manufacturing always refer to the outside diameter (O.D.).

| |
|--|
| 5/16" O.D. copper tubing must have a 1/4" I.D. |
| 3/8" O.D. copper tubing must have a 5/16" I.D. |
| 1/2" O.D. copper tubing must have a 7/16" I.D. |
| 3/4" O.D. copper tubing must have a 5/8" I.D. |

All respective fittings used with the above tubing must have the same minimum I.D. flow capacity. This is to avoid flow restrictions. Before putting to operation, air piping should be cleaned one section at a time by flushing out with the available storage tank pressure at a minimum of 100 psi. The lubricator for this operation is best kept dry. The regulator should be adjusted as per our drawings. The filter must be kept clean and dry during this operation. With the control heads disconnected, the supply line to the control heads must be flushed out first for approximately 1 minute from the engine room to the joint before the control heads. The control head(s) can then be reconnected to the air line after the flush and the corresponding lines at the control panel in the engine room are then to be disconnected. Each control head is to be activated in the clutch mode



first to flush the lines downstream for about 1 minute. After this step is completed, the lines at the engine and gear should be disconnected and flushed from one station only. Any malfunction or leakage in the Kobelt control valves caused by dirt in the system will be repaired at customer's expense.

The Air Treatment Unit

After the air lines are properly cleaned, the lubricator must be filled sparingly with SAE grade 10 hydraulic oil. Very often, lubricators get filled with the wrong fluid or improperly adjusted so no lubrication or over-lubrication results. A properly adjusted and maintained lubricator will improve the life of the control equipment. In general, the basic Kobelt control system will operate from six to twelve years without need for major maintenance. The air storage tank and air filter should be drained regularly to avoid water entering the control system. In sub-zero weather it is recommended to have an anti-freeze unit or special air drying equipment to avoid freezing in the pneumatic system.

Multi-Station Controls

In a multi-station control system, the service air supply is only available to one station at a time. The air pressure can be transferred with Kobelt palm valve 3517 and pilot operated 3403 or 3405 transfer valve. Several methods of station transfer are available in order to comply with various inspection authorities rules.

The resulting lines from the control heads must be interconnected with two-way check valves (shuttle valve P/N 3009). It is important that the shuttle valves are installed horizontally in a location that will minimize tubing runs. Shuttle valves that are installed in boats for future additional stations must be left open to the atmosphere. Plugging the unused ports will cause failure of the control system.

Quick Release Valve

Quick release valves are required on long tubing runs to exhaust the control air rapidly. For this reason, these release valves should be placed in the control circuitry at locations where they serve their purpose best. For example, if a large cylinder with a reasonably long line leading to the control valve is too slow in dumping the air through the control valve, the quick release valve should be installed near the cylinder in order to dump the large volume of air in the cylinder to atmosphere almost instantly rather than returning the air part way up the control line. If the control system has a small volume device at the end of the control line and is dumping too slowly, the quick release valve should be installed approximately one third away from the control head. Since the quick release valve is primarily intended to dump air very quickly, it would handle approximately two thirds of the line and the control head would be dumping the other one third of the line, thus giving a very fast response.

Quick release valves are not recommended in control systems with variable pressure outputs requiring a high degree of repeatability or accuracy as the quick release valve generates hysteresis. The quick release valve should always be installed with the exhaust port facing down to avoid dirt entering the valve. The ports on our quick release valves are clearly marked for all the necessary connections. If only one air outlet is required, the other port must be plugged. It is important that the exhaust port must not be plugged since this will make the valve inoperative.

INSTALLING ACTUATORS ON PROPULSION ENGINES AND GEARS

Brackets in most cases are required to adapt our actuators to the propulsion machinery. Under no circumstance must these brackets be welded on the machinery. Existing bolts as provided by the manufacturer can be used. Care must be taken that the installation of our actuators and brackets does not interfere with the accessibility of the engine and gear for regular maintenance. It is recommended that a section of rubber hose is used to connect our actuators to the copper tubing.

Kobelt Manufacturing provides two different clutch actuators, model 4204 and 4207.

Model 4204



The model 4204 provides one inch of stroke in either direction. If this clutch cylinder is attached to the control valve lever, care must be taken that the output rod is at 90 degrees to the control valve lever in the neutral position. The hole in the control valve lever must be selected to provide full engagement in both directions without over-traveling the maximum available movement of the control valve. A little free play at either extreme position is essential. The cylinder must be arranged to provide free motion throughout the whole angular operation of the valve lever without side binding. The lever to be actuated should not have a resistance of more than 40 lbs. in order to stay well within the safety limits of the cylinder forces.

Model 4207

The model 4207 is designed with an output lever which provides seven different possibilities of stroking the gear control valve. By reversing the output lever, an additional seven positions can be obtained (see product sheet). The output lever housing can be rotated at 45 degree increments. A connecting link must be provided between the output lever of the 4207 and the control valve lever. It is important that these two levers are parallel and that the connecting link is at 90 degrees to both levers in the neutral position. The linkage must be arranged so that when the cylinder is in neutral position, the gear control valve is also in neutral position. Furthermore, the linkage must be attached on the 4207 output lever to provide full gear engagement without over-stroking the valve. A little clearance on either end is essential. The connecting link between the two levers should be made of 5/16" diameter steel rod and should not exceed 18" in length. The rod end fittings should be of good quality that will provide years of trouble free service. Also, a locking nut should be provided on either end of the connecting link against the rod end fitting. These nuts should be secured to avoid wear. The rod end fitting must be installed that permits free movement without binding. Care must be taken to prevent torsional loading between the rod ends. At the longest lever position 2-3/8" stroke in either direction) the lever to be actuated should not have a resistance of more than 20 lb., and 32 lbs at mid lever position (1-5/8" stroke in either direction). At the shortest lever position (1-1/16" stroke in either direction) the lever to be actuated should not have a resistance of more than 45 lbs.

Throttle Actuators 4106 / 4107 / 4108

Three throttle actuators are available from Kobelt. It is important that these actuators match the operating pressure of the control head.

Model 4106 is designed for light duty throttles when little force is required to accelerate or decelerate engines. Model 4107 is a medium duty speed setting device and model 4108 is used to control engines with a stiff governor. It is very important that the actuator is capable of moving the throttle from the idling position to the full open position smoothly. The linkage should be substantial strong enough to withstand the vibration and the mechanical loads.

It is recommended that periodic inspections be made to all control equipment installed on engines and gears. Due to the high frequency vibration of such machinery, wear can sometimes result prematurely on actuators as described above. It is important that the control tubing leading to the engine does not create the electrolysis effect through the actuators.

TROUBLESHOOTING GUIDE FOR BASIC PNEUMATIC CONTROL SYSTEMS NOT INCLUDING THE TIME DELAY SYSTEMS

The most important factor during the installation of a pneumatic control system is to avoid dirt entering the tubing and control components. This could cause valves to leak or stick.

Troubleshooting should be done one section at a time starting from the air source right to the end of the line.

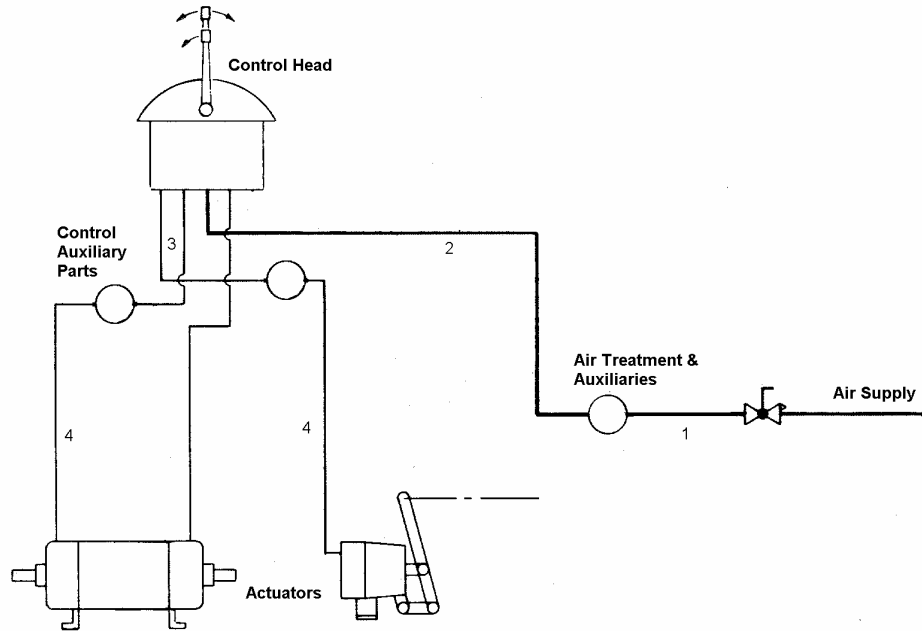

The first thing to check if control failure occurs is the air preparation unit and source of supply (filter, regulator, lubricator). It is important that the filter is kept drained and clean periodically. The regulator should be set at a minimum of 90 psi (higher pressures in some cases). The lubricator should be filled with a #10 hydraulic oil. At the end of the air preparation unit, a good flow of air should be available and an additional test gauge might be necessary to confirm the pressure regulator setting.

In order to troubleshoot the system, it is best to have full bottle(s) of compressed air available, shut down all running engines to obtain a silent ship. Place control head into forward idling position and listen for air rushing through control head downstream to actuator. Then follow control lines to the engine room and check for leaks right to the actuator. When the control head is returned to its neutral position, listen for the air exhausting through exhaust ports. Repeat same procedure for reverse direction and for engine speed section.

When the control head is placed in forward position and air leaks through the reverse side of the clutch valve, (or vice versa) the clutch actuator is leaking. Check and replace seals as necessary. On a multi-station system, if the air leaks through the actuated head, the problem lies in that same head. If air leaks through another (inactive) head, the problem lies in the shuttle valve system. This can be easily traced from either head. Once the shuttle valve is found, remove dirt or replace seals.

If no movement takes place in either clutch or throttle actuator, remove the air lines connected to same. Actuate control head to see if air pressure is available. If air pressure is available, remove and dismantle actuator to find worn or damaged seals, or dirt in the system. Repair as necessary. If rolling diaphragm needs replacing, ensure correct installation (fabric side of diaphragm is piston side, rubber side of diaphragm is pressure side). When re-assembling, ensure good lubrication of all seals and moving parts with oil or very light grease. Cleanliness during re-assembly is of utmost importance.



If the air pressure does not reach the end of the line attached to the actuator, the fault would be in the control head, or possible clogged shuttle valves or damaged tubing. Check all outgoing ports from the control head to ensure that full line pressure for the clutch actuation and variable air pressure at the throttle ports are available. Check that there are no plugs in the exhaust ports.

If no air flow for the clutch is detected, check needle valve on 2540 series heads for correct position. The needle valve should be open approximately two to three turns. Also check adjustment screws for operating valve spool so that half the mechanical movement of the cam is closing the valve and the remaining half is opening the valve.

If these screws are not properly adjusted, the valve could have very little supply capabilities and lots of exhaust volume. This would cause the clutch to engage very slowly or not at all. Turn screw down to correct problem. If the screw is turned down too far, plenty of supply air is available but the air will exhaust very slowly or not at all. Turn screw up. If no air passes through the valve, remove same and repair. If the valve poppet shows a small amount of damage, use a piece of sandpaper or emery cloth, place same on a flat surface to smoothen the seal. Replace "O" rings if necessary.

If the throttle valve is not performing to original setting, it can be adjusted with the upper or lower adjusting screw. Please see our sheet on General Installation and Adjustment Instruction for Variable Control Heads. Dirt will cause this valve to either leak or stick. Dismantle, clean and install new parts as needed. When replacing diaphragm, make sure piston side of diaphragm is facing piston.

It is also possible that a lack of supply air is caused by the station transfer system. If the control stations are far apart, it is important that the palm valve 3517 is depressed long enough to ensure a complete shift of the 3403 or 3405 station transfer valve. Improper adjustment of the screws operating the valve spool could again cause either a slow charge or discharge of the control system during station transfer. Check that half the travel is available for the charge of the control system and half for the exhaust. Again the poppet in this valve can be cleaned with sandpaper or emery cloth. Replace "O" ring if needed.

Very often linkages between our actuator and gear control valve lever and governor lever are improperly installed or matched. It is very important that a gear control valve is moved to the full gear engaged position and not beyond. It is also important that the linkage provides alignment in neutral position. The linkage must be at 90 degrees to the levers in the neutral position. The axis of rotation must be on the same plane. The actuator controlling the engine governor must have the same pressure range as the control head. Again the linkage must be installed to provide complete movement of the actuator from idle to maximum RPM without bottoming the governor lever in either direction. If the pressure range or actuator stroke does not match to the engine speed setting device, engine speed control can be very erratic.



GENERAL INSTALLATION AND ADJUSTMENT INSTRUCTIONS FOR VARIABLE PRESSURE CONTROL HEADS

Before making the cut-out for the control head on a control panel, it is important to consider the surrounding control equipment on the surface of the control panel as well as accessibility beneath the control panel for the installation of pneumatic tubing and possible adjustment or removal of the control valves.

It is important that all control heads are installed on a flat, smooth and solid surface. Bolting the control head frame onto an uneven surface will cause deformation of the main frame which in turn will result in binding of the control handle shaft in the bearing sections. In order to obtain a water tight joint between the control head and the mounting surface, a small amount of silicon or a thin gasket should be used between the two surfaces.

During installation, the control head should be kept clean and free from sawdust, metal chips and dirt as this could interfere with the longevity of the control head. The fittings on the control head must be clean and installed with a pipe sealant (Teflon tape is not recommended). Over-tightening of the pipe fittings could result in splitting of the control head castings.

The exhaust ports on our three- and four-way valves are provided with a pipe threads. The exhaust air can be piped away from the operator stand if so desired. The exhaust ports on our compensating pressure regulating valves are not threaded. A restriction at this port could cause the valve to hammer when the control air pressure is released to atmosphere. It is therefore best to leave the exhaust port unrestricted and not covered with any objects.

Tubing sizes are specified in our system drawings. Please take note of this. It is of extreme importance to keep the tubing free of foreign matter since dirt in the valves could cause leakage or inaccuracy. The control head shafts, pins, and rollers should be lubricated periodically with a good quality oil or grease.

All Kobelt control heads are equipped with adjustable detents and/or frictions which can be adjusted to the operators' requirements in the field.

The drawings on next page show locations of all adjusting screws which will affect the setting of the control head.

Adjustment No. 1 – This set screw can be adjusted to preload a valve to a minimum starting pressure.

Adjustment No. 2 – This set screw must be adjusted in conjunction with the adjusting screw at the bottom (adjustment no. 1). If the pressure range needs to be increased, the screw can be turned downwards towards the valve. If the valve responds too slowly to mechanical movements the slack can also be taken up with the set screw (adjustment no. 1).

Adjustment No. 3 – These two screws with jam nuts provide maximum handle travel stop which will result in a maximum output pressure limitation. For example, if adjustment No. 1 and 2 have been correctly made to establish a minimum pressure, the maximum pressure can now be set with these stop screws. Various springs are available as indicated in our product sheets to provide pressure ranges from 60-120 psi. Adjustment screw No. 3 should only be used for minor pressure adjustments.

Adjustment No. 4 – Adjustable nylon friction with spring and set screw. The set screw can be set to obtain the required drag on the handle to avoid creeping.

Adjustment No. 5 – Adjustable detent with stainless steel plunger, spring and set screw. This adjustment can be set to provide the required feel of the detent (roller for 2570 series).

Adjustment No. 6 – These adjusting screws should be adjusted so that one half the travel of the valve plunger will provide closing of the exhaust and the other half of the travel will open the valve to supply air to the clutch control circuit.

Adjustment No. 7 – Eccentric adjustment for the throttle cam. This adjustment provides an up and down motion for the roller contacting the main control cam and will permit adjustments of equal starting pressure in both gear engage positions. (Applies to 2540 series only).

Adjustment No. 8 – Provides supply flow control and therefore governs the volume of air to the clutch control circuit without affecting the exhaust capacity.

Adjustment No. 9 – On the 2570 series, will provide infinite adjustment of the cams controlling the pressure. Assembly screws holding the cam to the main drive spider hub must be loosened slightly. This will permit the cams to be altered, which will result in a change of mechanical movement of the pressure compensating valve leading to a change of output pressure. Several springs are available to assist in selecting the proper pressure range.

Adjustment No. 10 – Slidable adjustment for throttle arm. By sliding the roller link within the slots provided, the starting control pressure can be equalized in both directions.

It is important to assure that all screws, bolts and nuts are securely tightened.

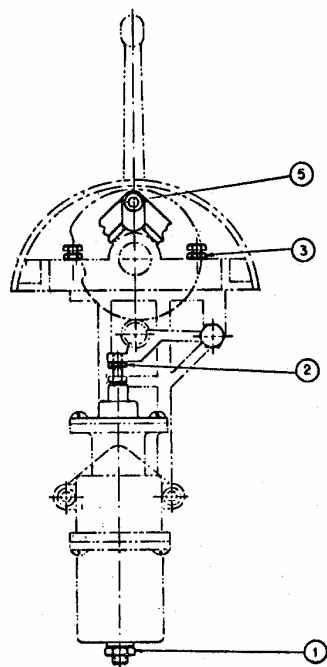

**INSTALLATION AND ADJUSTMENT
INSTRUCTIONS FOR VARIABLE PRESSURE
CONTROL HEAD 2542**

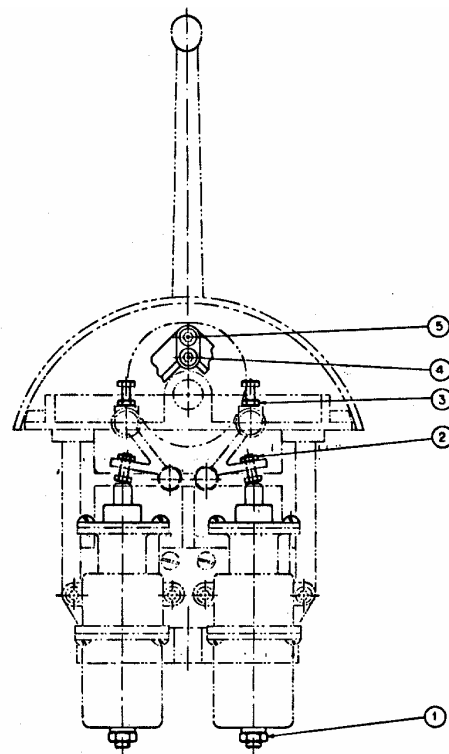

**INSTALLATION AND ADJUSTMENT
INSTRUCTIONS FOR VARIABLE
PRESSURE CONTROL HEADS
2543 - 2546 - 2547**

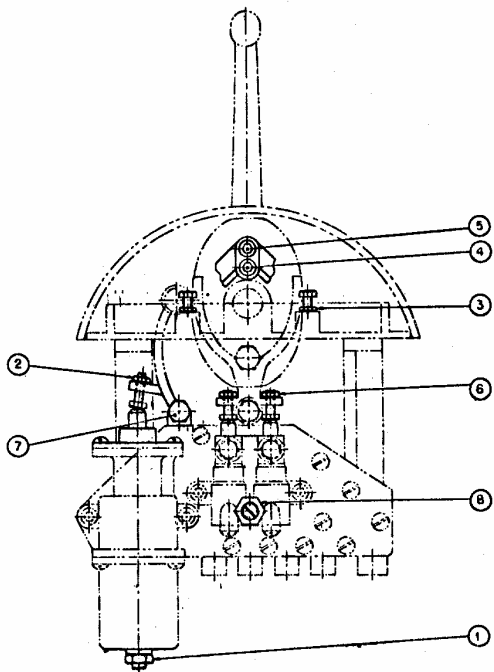

**INSTALLATION AND ADJUSTMENT
INSTRUCTIONS FOR VARIABLE
PRESSURE CONTROL HEADS
2544 - 2545 - 2534**

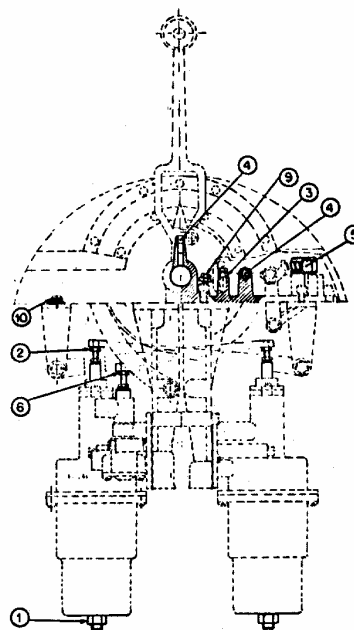

**INSTALLATION AND ADJUSTMENT
INSTRUCTIONS FOR VARIABLE
PRESSURE HEADS
2571-2572-2573-2574-2575-
2576-2577-78-79**



ADJUSTMENT INSTRUCTIONS FOR

CONSTANT TIMING CONTROL PANELS FOR HYDRAULIC GEARS

The remote control signal entering the clutch circuit via ports C1 and C2 will trip either relay valve A or B into an open position. The engine room air supply (AS) will then energize the interlock valves and clutch actuator. The adjustments on relay valves A and B should be set at approximately 30 psi. If the clutch relay A is energized, the output from this relay is permitted to enter into the accumulator tank BC immediately, therefore, locking out relay valve B. When a reverse maneuver is made, the clutch valve B is energized and the accumulated air pressure in the accumulator tank BC must exit via needle valve BC before clutch engagement can take place in the opposite direction. Closing needle valves (clockwise) prolongs the delay in the clutch neutral position. Opening the needle valves (counterclockwise) will increase the volume of air exiting through the needle valves and therefore reduces the neutral time delay. This allows for separate time delay settings for the forward and reverse clutches.

ILLUSTRATION EXAMPLE 1: 2850-1110

Constant Timing, Single Engine, Throttle Delay

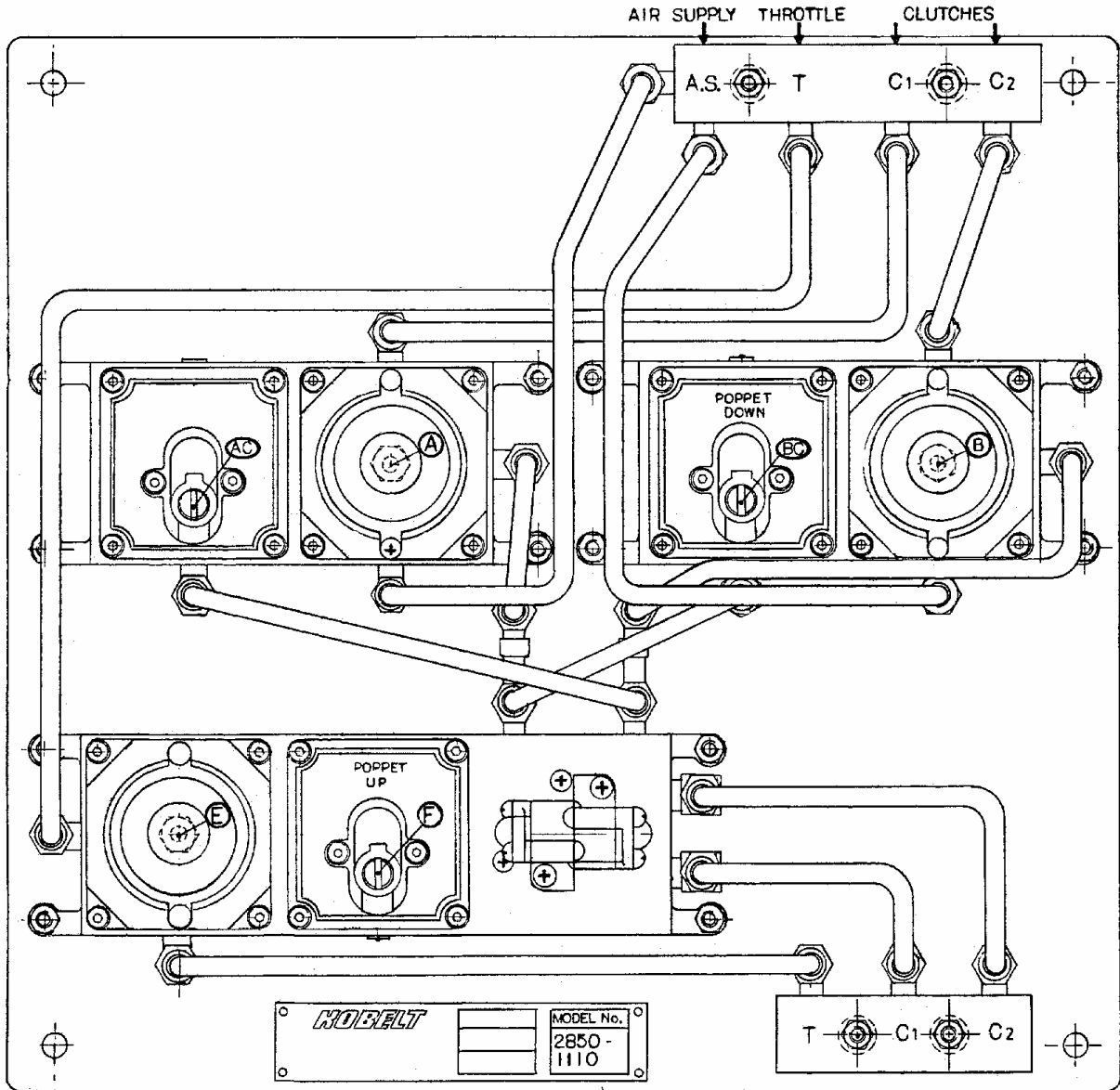

CONTROL ADJUSTMENTS FOR

VARIABLE TIMING CONTROL PANELS FOR HYDRAULIC GEARS (2850-3xxx)

The remote control clutch signals enter the variable timing panels via ports C1 and C2 into relay valves AA and BB. The remote control signals trip either one of these valves into an open position. Engine room air supply (AS) is permitted to charge the interlock valves and clutch actuator. The adjustments on relay valve AA and BB should be set at approximately 50 psi. The out-signal from the primary relay is allowed to enter into the primary variable timing manifold which consists of two relay valves (Item A and Item B), two accumulator tanks (Item AC and Item BC) and a flow control valve (mounted on Item AC). With the control in a neutral position, selecting a clutch direction, the air is allowed to pass through either relay valves and energize the clutch immediately. If the gear was previously in an engaged position and at half throttle, the throttle pressure will accumulate in both accumulator tanks via the flow control D and AC. Since the throttle pressure is in relation to the engine rpm and the speed of the ship, the throttle pressure venting is controlled by the discharge through need valve AC.

Clutch reversal is not made possible until the accumulated air has drained through needle valve AC. This demonstrates that the forward and reverse timing will vary according to engine speed. Needle valve D regulates the charge rate of the tanks. If a boat accelerates very quickly, the tanks should be fully charged in approximately 10 seconds. If a boat accelerates slowly, the accumulator tanks should be charged in 20 – 25 seconds. Gear reversal, without engine speed, will take place almost instantly. At full engine rpm, gear reversal will consequently take longer since a major amount of accumulated throttle air must exit through flow control valve AC. Adjusting flow control valve AC, turning clockwise, will prolong the neutral time delay. Turning flow control valve AC counterclockwise will shorten the neutral time delay. Adjustments for A and B, secondary regulating valves, shall be set at 30 psi.

ILLUSTRATION EXAMPLE 2: 2850-3141

Variable Timing, Single Engine, Throttle Delay, Throttle Boost, Minimum Timing, Shaft Brake

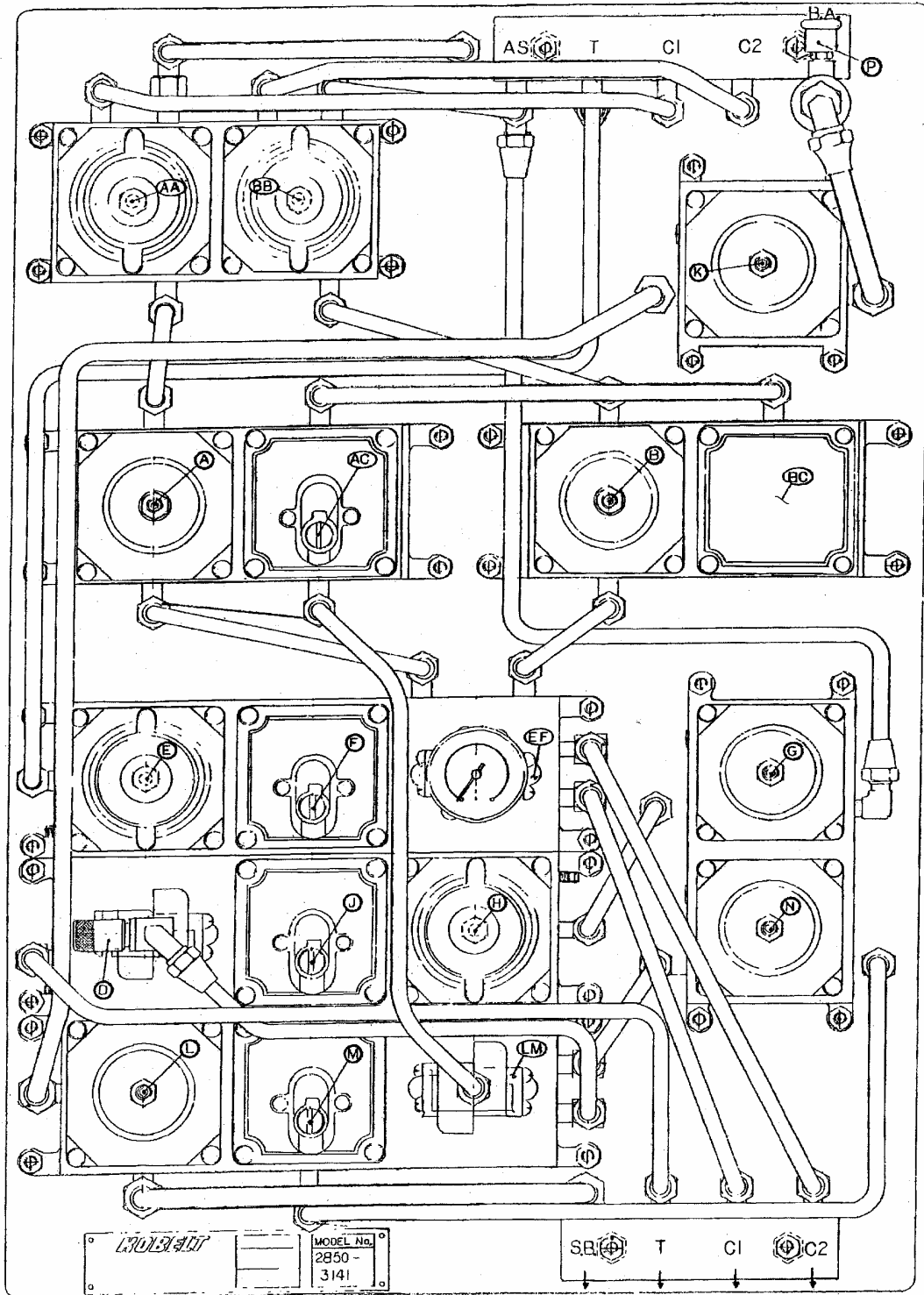

THROTTLE BOOST

The throttle boost consists of three adjustments:

- (1) Starting point of boost
- (2) Stopping point of boost
- (3) Amount of boost

Adjusting the pressure regulator (G) will control the output pressure. It is recommended that this regulator be set at approximately 25 psi. Adjustment H governs the starting point of the boost. It is recommended that the pressure setting be maintained at 25 psi. The flow control valve J regulates the cut-off point of the boost. If the boost comes in too late, adjustment H must be set lower. If the boost comes off too soon, needle valve J must be turned in clockwise. If the boost stays on too long, adjustment H must be turned out counterclockwise. If the boost is too low, adjustment G should be turned in clockwise.

THROTTLE DELAY

The shuttle valve EF give a pilot signal in either a forward or reverse running position, into the accumulator tank F. The air enters this tank via needle valve F. Turning the needle valve out, or counterclockwise, will allow the air to accumulate at a more rapid rate and therefore opens the relay valve Item E faster. Closing the needle valve Item F by turning clockwise, will prolong the accumulation of air into the tank and delay the opening of relay valve E. This in turn will delay the opening of the throttle which avoids engine acceleration during gear engagement. Relay valve E should be set at approximately 70 psi. These instructions apply to all timing panels. Any additional timing functions, such as throttle boost and shaft brake, do not affect the primary settings as given.

MINIMUM TIMING FOR HYDRAULIC GEARS

Minimum time in conjunction with variable timing will give a control minimum neutral time delay. The throttle pressure passing through flow control valve D is fed into shuttle valve LM and passes via its regulator outing into the variable timing accumulator tanks, AC and BC. The pressure regulator, with adjustment N, is fed off the clutch pilot line. Whenever gear engagement occurs, this regulator is charged with clutch pressure. Turning adjustment N in or clockwise, will prolong minimum timing. Conversely, turning adjustment N out or counterclockwise, will decrease the pressure setting and shorten the neutral time delay.

PROPELLER SHAFT BRAKE

The relay valve K provides the amount of air pressure required to stop the propeller via Kobelt disc brakes. Item L is a normally open relay valve in a neutral gear position. When clutch pressure enters the accumulator tank via shuttle valve EF, the relay valve will trip into a closed and exhaust position, releasing the brakes. A quick release valve should be installed near the brakes to allow a fast dump of the air in the brake actuators. Adjustment K should be set between 70 and 100 psi. This adjustment regulates the amount of output pressure to the brake. If the brake torque is not sufficient, the air pressure should be raised. If the brake comes on too severe, the pressure must be lowered. Turning adjustment K out or counterclockwise will lower the pressure. Adjustment L on the brake relay governs the releasing point of the brake. If the brake releases too late, adjustment L must be turned out or counter-clockwise. If the brake applies too soon, needle valve M must be turned in or clockwise. If the brake comes on too late, the needle valve must be turned out or counter-clockwise.

When setting the propeller shaft time during sea trial, it is extremely important to set the brake so that no overlapping in clutch timing or brake timing takes place. It is also important to set the brake to prevent propeller shaft rollback between clutch engagement and brake release. After all adjustments are made, it is important to secure all needle valves with the locking screws and also to lock setting screws on all relay valves and regulators with the appropriate locknuts.

OVERRIDING AND INTERLOCKED THROTTLE REF. DWG #2850-1112

The purpose of an over-riding throttle is to allow engine acceleration in a neutral gear position since it is not possible to get a throttle signal past the interlocks in normal operation.

It is necessary to employ two relay valves to divert the throttle signal past the regular timing units. At the station where an over-riding throttle is desired, a 3-way valve for each engine, Model 3514 or Model 3516 is employed. The regular air supply to these 3-way valves must be from the same source as the control head itself.

If the 3-way valve is in the closed position, no pressure signal enters the port **TP** on the timing panel. Therefore, the normally open relay **TO** is in its open position allowing the air supply to go to the regular interlocking relays. The relay valve **TC** which is normally closed, remains in the closed position not allowing any throttle signal to bypass the regular timing units. The 3-way valve, being in the closed position in the normal operating mode, does not allow over-riding throttle. If the 3-way valve is in an open position, a pilot signal enters port **TP**. This signal will, in fact, close relay valve **TO** and will, therefore, make the clutch inoperative (remain in neutral). It is not possible to engage the gear in this mode. The throttle signal entering the panel is now permitted to pass through relay valve **TC** and shuttle valve **TS**, exiting through port **T** to the engine speed control device.

The pressure setting adjustment on relay valve **TO** should be approximately 30 psi. To raise the pressure setting, loosen jam nut and turn setscrew clockwise. To lower the pressure setting, loosen jam nut and turn setscrew anti-clockwise. The pressure setting on relay valve **TC** should be set at approximately 70 psi. Remove cap and loosen jam nut (two wrenches are required). To increase pressure setting, turn the nut nearest to the spring washer clockwise and turn anti-clockwise to lower the setting.

The above system allows operation of a single lever control, eliminating the clutch function and maintaining control over the engine speed in the speed range.

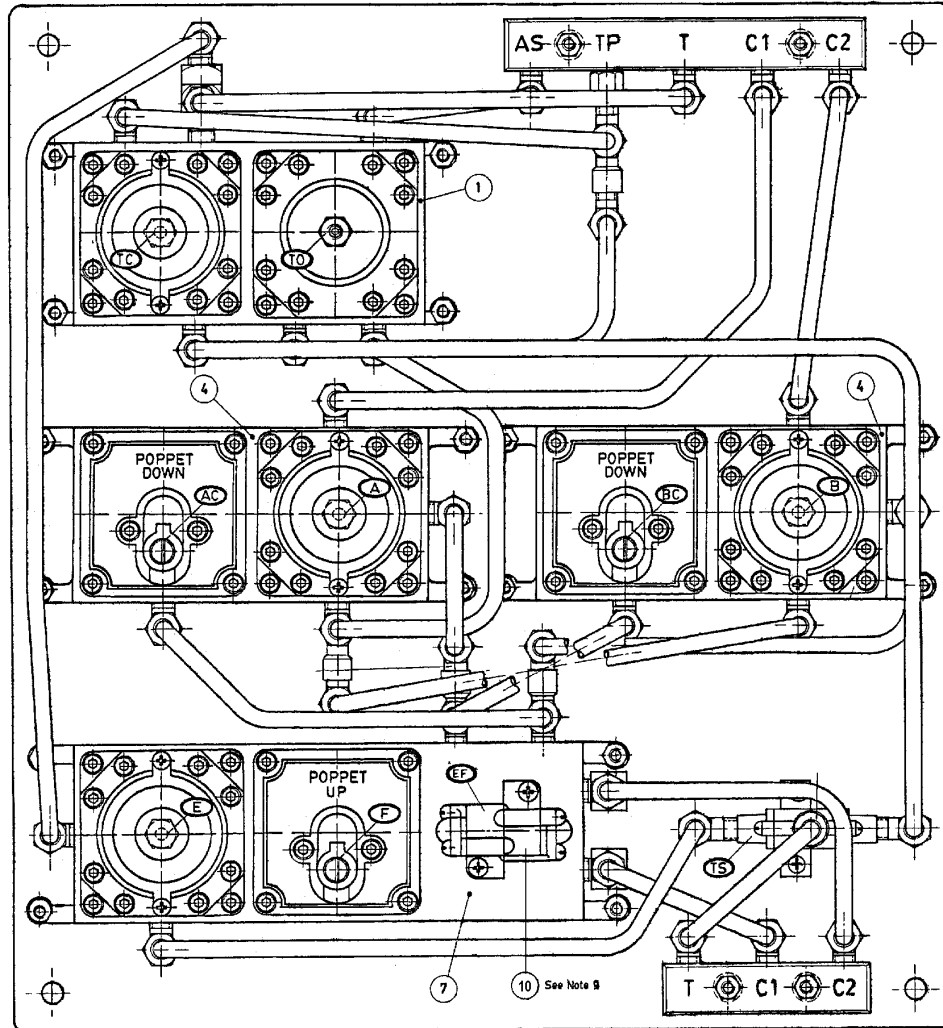

Drawing 2850-1112

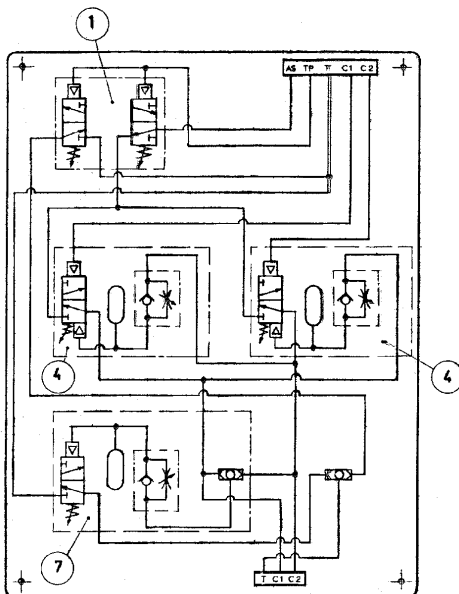

Notes:

- 1) Dimensions in inches (mm)
- 2) Header bar ports are 1/4" NPT
- 3) All lines shall be 5/16" OD copper tubing
- 4) Keep all lines and fittings free of dirt during installation
- 5) Use pipe sealant on all pipe fittings to prevent leakage (teflon tape is not recommended)
- 6) Components, piping arrangement and dimensions are for reference only and subject to change without notice unless certified
- 7) Height of assembled panel is 7 1/7" (185 mm). Clear this height to allow for valve adjustment
- 8) Air supply (AS) for control heads and air supply on panel must be from common source
- 9) If gauge is desired to read outgoing clutch pressure, shuttle valve 3008 (item 10) must be replaced with shuttle valve 3011 (with gauge port and pressure gauge) at extra cost

Schematic Diagram

BASIC PNEUMATICS MAINTENANCE PRINCIPLES

For optimum performance from a pneumatic control system it is imperative that the lines and components be free of any dirt or debris.

Ensure that the FLR (Filter, Regulator and Lubricator) unit is functioning properly. Filter drained and clean, regulator set to a minimum of 90 PSI and lubricator filled with an ISO#10 grade light hydraulic oil.

With system fully charged and engines off inspect lines and components for leaks which will emit a noticeable hissing sound where air is leaving the system.

Inspect mechanical connections for wear, fit and proper fastening.

Repair leaks or damaged components as soon as they are discovered to prevent further damage to the operating system.

A pneumatic control system will provide years of trouble free service if the above items are addressed on a regular basis.

Periodic Inspection

All mechanical and electronic components should be inspected at regular intervals, once every 6 – 12 months is recommended depending on the operating environment and frequency of use. Some Kobelt components are equipped with inspection covers which can be removed for examination of internal parts.

The following serves as a general inspection guideline for Kobelt engine control and steering control system components. All deficiencies have to be fixed and defective parts be replaced by a certified technician to ensure a reliable and safe operation.

1. Inspect all mechanical linkages for proper movement and the bolts and nuts are tight for their functions.
2. Inspect all push / pull cable connections for free movement, adjust if necessary.
3. Check for corrosion and excessive wear at all moving parts that could cause problem in normal operation.
4. Apply lubricating oil / grease to mechanical parts at all available greasing points. Make sure that no oil or grease will come into contact with any electronic parts. For gears and rotating shafts, use of graphite-base grease is recommended.
5. Check for signs of moisture ingress or condensation that could cause short-circuit or corrosion problem to electrical / electronic components. Surfaces of all electronic parts should be free from moisture, dust or foreign particles.
6. Check seals and holding screws on housings for damage and tightness.
7. Verify that primary and secondary power sources are at normal values.
8. Inspect system wiring for insulation breakdown, loose connections or potential for short-circuit failure.
9. Check limit switches for corrosion, smooth operation and correct positioning.
10. With the engine not running, perform functional test for each system – refer to individual component operating and test procedures.