

# **KOBELT**

## **HPU100 Accu-Steer Hydraulic Power Unit**

*Owner's Operation, Installation &  
Maintenance Manual*

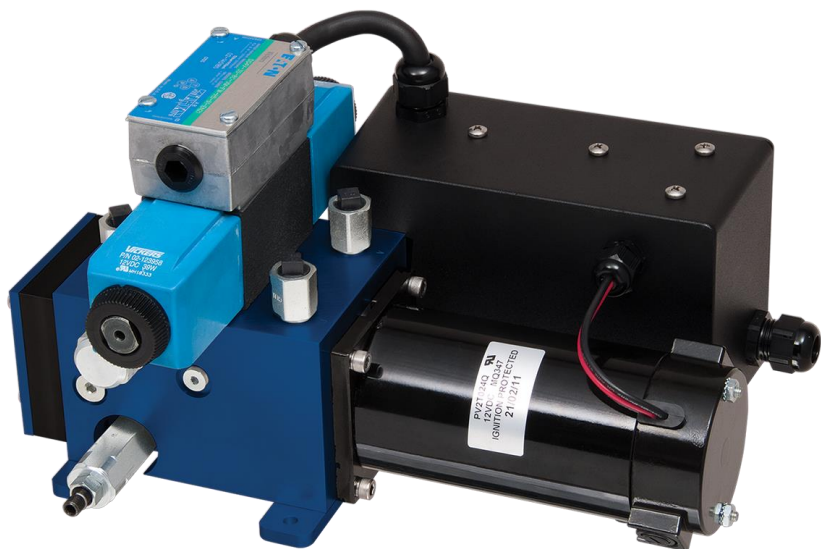

August 2019

Kobel Manufacturing Co. Ltd.



# TABLE OF CONTENTS

---

<b>1</b>	<b>Introduction .....</b>	<b>4</b>
1.1	Contact .....	4
1.2	Safety .....	4
<b>2</b>	<b>Product Description .....</b>	<b>6</b>
2.1	Components .....	7
2.2	Technical Specifications .....	7
<b>3</b>	<b>Installation .....</b>	<b>10</b>
3.1	Mechanical .....	10
3.2	Hydraulic.....	10
3.3	Electrical .....	11
<b>4</b>	<b>Commissioning .....</b>	<b>17</b>
4.1	Hydraulic Fill & Bleed .....	17
4.2	Electrical Check .....	17
4.3	Functional Test .....	18
<b>5</b>	<b>Operation.....</b>	<b>19</b>
<b>6</b>	<b>Maintenance .....</b>	<b>20</b>
6.1	Preventative Maintenance.....	20
6.2	Recommended Spare Parts.....	21
<b>7</b>	<b>Troubleshooting .....</b>	<b>22</b>
<b>8</b>	<b>Warranty.....</b>	<b>23</b>
<b>9</b>	<b>Appendix A: Installation Dimensions.....</b>	<b>24</b>
<b>10</b>	<b>Appendix B: Parts List .....</b>	<b>25</b>
<b>11</b>	<b>Appendix C: Manifold Assembly Parts .....</b>	<b>27</b>
<b>12</b>	<b>Appendix D: Electrical Box Assembly Parts .....</b>	<b>29</b>
<b>13</b>	<b>Appendix D: Typical System Arrangement.....</b>	<b>31</b>
<b>14</b>	<b>Appendix E: Brush Replacement .....</b>	<b>32</b>
<b>15</b>	<b>Appendix F: Shaft Seal Replacement .....</b>	<b>33</b>

# 1 INTRODUCTION

## 1.1 CONTACT

**Kobel Manufacturing Co. Ltd.**  
8238-129th Street  
Surrey, British Columbia  
Canada, V3W 0A6

Sales Tel: +1-604-572-3935  
Fax: +1-604-590-8313  
Email: [sales@kobelt.com](mailto:sales@kobelt.com)  
Website: [www.kobelt.com](http://www.kobelt.com)



This document is intended to clearly present comprehensive product data and provide technical information to assist the end user in design applications. Kobelt reserves the right, without notice, to change the design, or construction, of any products and to discontinue or limit distribution of any products. Kobelt also reserves the right to change, or update, without notice, any technical information contained within this document.

Kobel recommends that customers visit our website to check for updates to this Manual. Once a product has been selected for use, it should be tested by the user to ensure proper function in all possible applications. For further instructions, please contact our distributors or visit our website.

## 1.2 SAFETY

### 1.2.1 Safety Alerts

Throughout this manual, the following symbols, and their accompanying explanation, are used to alert the user to special instructions concerning a service or operation that may be hazardous if performed incorrectly or carelessly. The associated risk levels are stated below.





 <b>DANGER</b>	This symbol indicates an imminently hazardous situation which, if not avoided, will result in death or serious injury.
 <b>WARNING</b>	This symbol indicates a potentially hazardous situation which, if not avoided, could result in death or serious injury.
 <b>CAUTION</b>	This symbol indicates a hazardous situation, which if not avoided, could result in minor or moderate injury.
<b>NOTICE</b>	This symbol informs the reader of events not related to personal injury but which there is a risk of damage to property or equipment.
<b>SAFETY INSTRUCTIONS</b>	This symbol informs the reader of safety-related instructions or procedures.

### 1.2.2 Notice to Installer

Disregarding the following safety measures can result in an accident causing severe injury to personnel and damage to material assets.

- Only use the product as directed in this manual.
- Never put the product into service if there is evidence of visible damage.
- Never put the product into service before fully completing installation and commissioning.
- Do not carry out any modifications to the product.
- Only use authentic Kobelt spare parts.
- Observe all local regulations, directives and laws during the installation of this product.
- All installation, commissioning, and maintenance work must only be conducted by qualified personnel. (For the purpose of this manual, qualified personnel are persons who are familiar with the assembly, installation, commissioning, and operation of the product and who have the qualifications necessary for their occupation.)
- Observe all specifications in this manual. If these guidelines are not followed and damage occurs, the warranty will be voided.

### 1.2.3 Product Hazards

 <b>WARNING</b>	<p><b>High Pressure Operation:</b> This HPU unit generates high pressure hydraulics. Ensure all power sources are locked out prior to performing work.</p>
 <b>WARNING</b>	<p><b>Equipment Starts Automatically:</b> HPU units are controlled remotely and may activate suddenly causing bodily harm. Ensure all power sources are locked out prior to performing work.</p>
 <b>WARNING</b>	<p><b>Disconnect Power:</b> Turn off power at distribution panel before beginning installation to protect installer from electrical hazards.</p>
 <b>CAUTION</b>	<p><b>Voltage and Current Compatibility:</b> Confirm that the power source is compatible with the maximum voltage and current ratings of is product variant. Failure to do so could result in damage or fire.</p>

## 2 PRODUCT DESCRIPTION

The Accu-Steer HPU100 pumpset is a continuous running pumpset designed to interface hydraulic steering systems with electric or autopilot control. As described, the motor runs continuously when started and the output oil is directed to the port or starboard line by operating the four-way solenoid valve mounted on the pumpset. Its compact and rugged construction provides ease of installation along with long life operation. This unit is available in both 12 VDC and 24 VDC configurations.

This pumpset is suitable for vessels with steering actuators up to 40 cu in (820 cc) or vessels up to 50 ft (15 m) in length. Proper pump selection and application is very important to optimize steering performance and pump longevity.

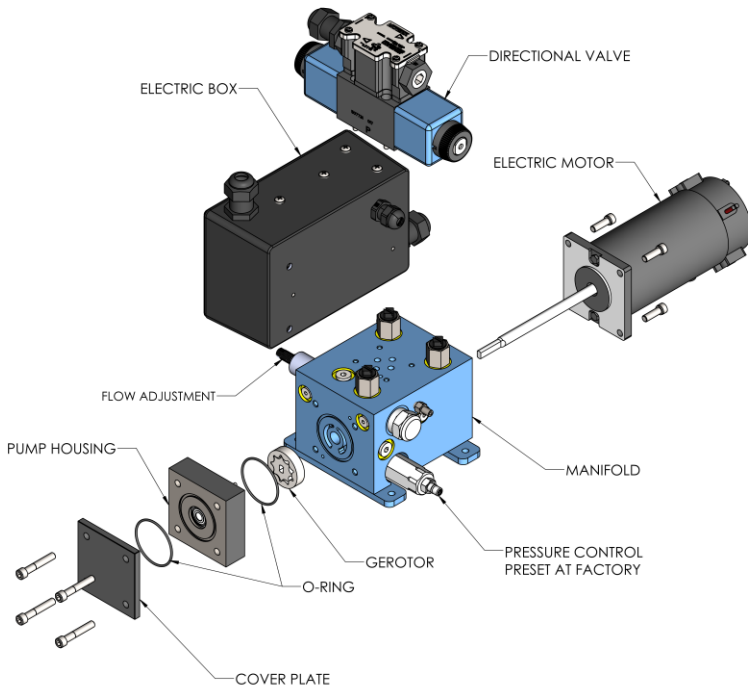

Figure 1: HPU100 Overview Diagram

## 2.1 COMPONENTS

The Accu-Steer HPU100 is a complete pump assembly consisting of a gerotor style pump, adjustable flow control, adjustable pressure release valve and an electric permanent magnet motor terminated in an electrical junction box. As the pump set is self-contained, installation involves connecting the unit to the steering lines and the electric control and adjusting the unit to the requirements of the steering system.

### 2.1.1 Electric Motor

The electric motor is a permanent magnet style D.C. motor featuring ball bearing supports and replaceable brush gear. The motor is directly coupled to the pump unit by a machined face. The electric motors are available in both 12 VDC and 24 VDC voltages.

### 2.1.2 Pump

The pump is a gerotor style gear unit with extremely quiet operation. Hydraulic flow control and pressure relief are adjustable. The pressure relief valves are factory set for 500 psi. and should not be altered in the field as it will change the electric motor current draw.

### 2.1.3 Hydraulic Manifold

The hydraulic manifold includes directional valve, flow control, pressure relief and by-pass valve. it also acts as a base to hold motor and pump. All adjustment and hydraulics line connected to manifold.

## 2.2 TECHNICAL SPECIFICATIONS

Table 1: HPU100 Technical Specifications

MODEL	HPU100-12	HPU100-24	HPU100S-24
KOBELT P/N:	600-031	600-032	600-032SS
NOMINAL VOLTAGE	12 VDC	24 VDC	
MOTOR CURRENT	No Load: 10 A Full Load: 30 A	No Load: 5 A Full Load: 15 A	
SOLENOID MAX. CURRENT	Direction: 2.5 A Speed: 1.7 A	Direction: 1.3 A Speed: 0.9 A	
MAX. OUTPUT	1.0 GPM [3.7 Lit. /min.]		
MAXIMUM ALLOWABLE PRESSURE	1000 PSI [70 bar] 50 PSI [3.4 bar]		
<ul style="list-style-type: none"> <li>• A &amp; B PORTS</li> <li>• T PORT</li> </ul>			
RELIEF PRESSURE	500 PSI [34 bar]		
VALVE WITH SOFT SHIFT	NO		YES
SERVICE DUTY	Intermittent: 20% ON / 80% OFF		
RECOMMENDED FLUID	ISO VG 32, VI 60 Hydraulic Oil		
PORT SIZE AT MANIFOLD BODY	-06 SAE ORB		
PORT ADAPTERS	-06 SAE ORB TO 1/4" NPT		
OPERATING TEMPERATURE	14... 122°F [-10... 50°C]		
PRODUCT WEIGHT	30 lbs [13.6 kg]		

### 2.2.1 Temperature Limits

The motor temperature has a maximum limit of 248°F [120°C]. Allowing the temperature to exceed this limit will permanently damage the motor windings. The maximum oil temperature limit is 149°F [65°C].

Observe the operating temperature range limits as presented in Table 1. Do not operate the unit if the ambient temperature where the unit is located exceeds these limits.

## **NOTICE**

Exceeding these temperatures may result in reduced operational life or damage to the product.

### 2.2.2 Pressure Range

The normal operating pressure of the unit is 0 to 500 psi. Avoid operating the unit against the rudder stops for prolonged periods of time.

### 2.2.3 Duty Cycle

The HPU100 is designed as an intermittently operated unit for normal steering applications. High demand applications will over work the motor and cause over heating.



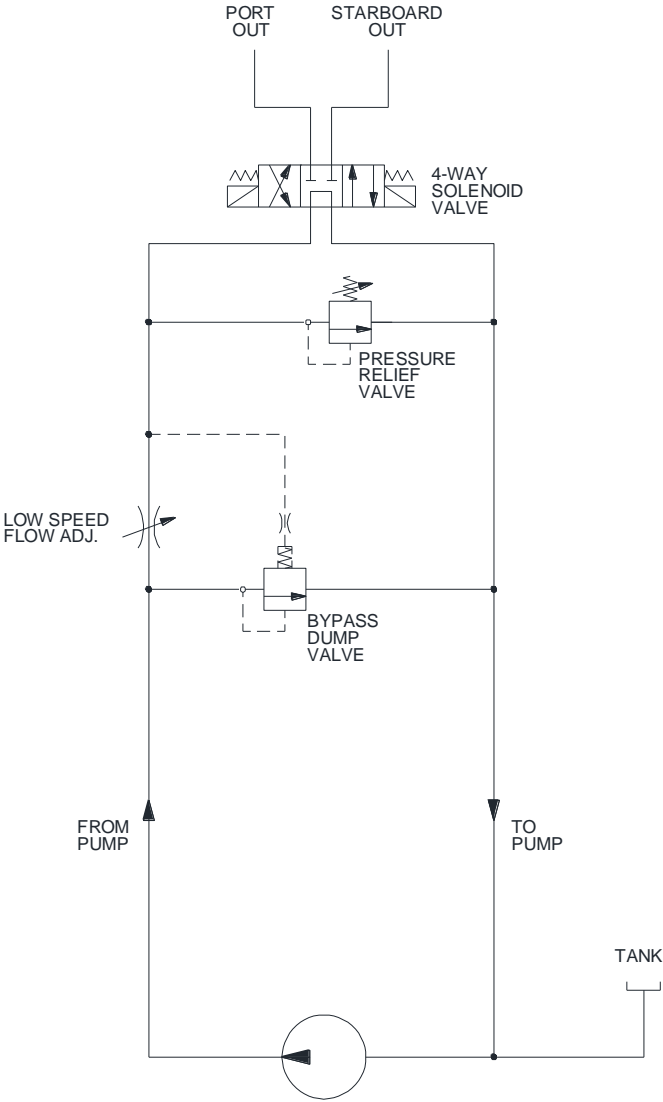

Figure 2: Hydraulic Schematic

## 3 INSTALLATION

---

### 3.1 MECHANICAL

The pumpset must be placed on a horizontal bracket with a solid foundation. It should be close to and below the steering lines for ease of connections and bleeding.

The HPU is equipped with (4) four holes for 1/4" bolts through the mounting feet. Ensure that the unit is securely fastened to a suitable foundation.

### 3.2 HYDRAULIC

Before connecting the hydraulic lines to the pumpset ensure all the hydraulic lines in the steering system have been flushed and that the hydraulic oil is free of any contamination, which may enter the pumpset and cause it to fail.

Most steering manufacturers have recommended hydraulic oils to be used in their systems. The HPU100 is compatible with these oils. Most manufacturers use an ISO #32 oil.

Three hydraulic connections are required to the pumpset. Two lines connect the main steering lines. The third line, which is the interconnect/fill line, connects the pumpset to the header tank or helm pump. This third line is critical as it provides make up oil and allows the pumpset to vent any air, which may enter the pumpset from the steering lines. It is recommended that flexible hose be used for all three lines to prevent any pump noise from being transmitted to the steering system. The two steering lines should have pressure rating of 1000 psi, where the third interconnection line is a non-pressure line. Shut off or isolation valves for all three lines are recommended. If the pumpset failed, the isolation valves can be shut, and manual steering regained.

#### **NOTICE**

Ensure the plugs remain in place until the unit is ready for connection.

#### **NOTICE**

All piping and hoses must be flushed prior to connection. Failure to do so can result in damaged components and seals.

The three hydraulic connections 9/16-18 UNF (-06) ORB with optional 1/4" NPT (National Pipe Thread) adaptor. If NPT adaptor is being used, a pipe thread sealant such as Teflon paste must be applied. When installing the hydraulic fittings, a pipe thread sealant such as Teflon paste must be used.

#### **NOTICE**

All hoses and piping must also be plugged or capped until ready for connection.

The piping to the steering cylinder should be minimum 1/4" nominal size with a suitable wall thickness to safely withstand the operating pressure. The Port and Starboard steering lines should have a pressure rating of 1000 psi minimum. Secure the piping against vibration with pipe clamps spaced every 3 feet [1 m].

The connections to the hydraulic manifold must be made by hoses of suitable rating to accommodate any movements, vibration or thermal strain.

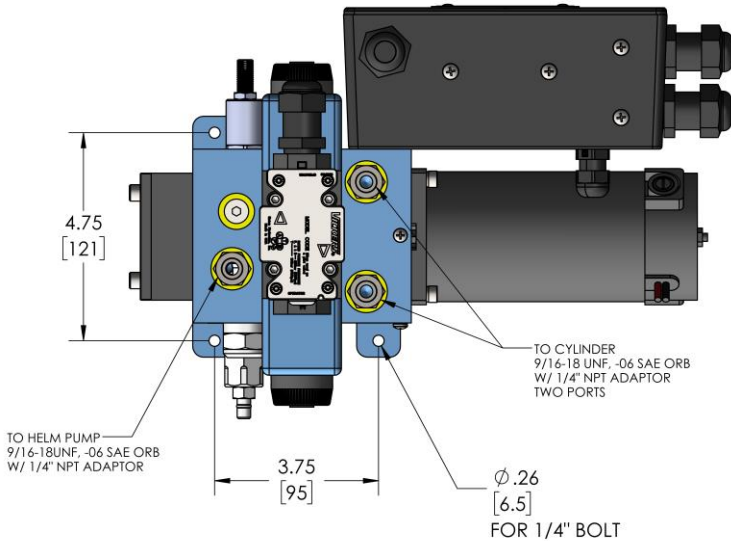

Figure 3: Connections in Top Face of Hydraulic Manifold

Three (3) hydraulic connections are required:

- Connect two "Cylinder ports" to the two steering cylinders. It is not critical to identify which of the steering lines is Port or Starboard as most new autopilots will determine the pump direction and program the drive outputs to suit.
- Connect the the third port to Header tank or helm pump case port.

### 3.3 ELECTRICAL

The pumpset units are manufactured for operation from either 12 VDC or 24 VDC dependent on the model number ordered. The Electrical Junction Box contains a remote start relay (voltage dependent), a thermal overload breaker, and a terminal strip for external connections. The DC start relay can be activated with a positive or negative switched signal.

Ensure that the electrical cable used to feed the main power to the motor of the HPU150 is sized properly to prevent voltage drop. Refer to ABYC or local boat electrical standards for applicable rating recommendations.

The solenoids use a common connection (Terminal 5) on the terminal strip and can be activated by a positive or a negative control signal. The Port and Starboard solenoid coils are connected to Terminals 6 and 7 respectively.

Some autopilots have a switched output or clutch/relay output that may be optionally used to operate the start relay.

 <b>CAUTION</b>	<b>DO NOT</b> energize these solenoid coils detached from the valve.
--	--

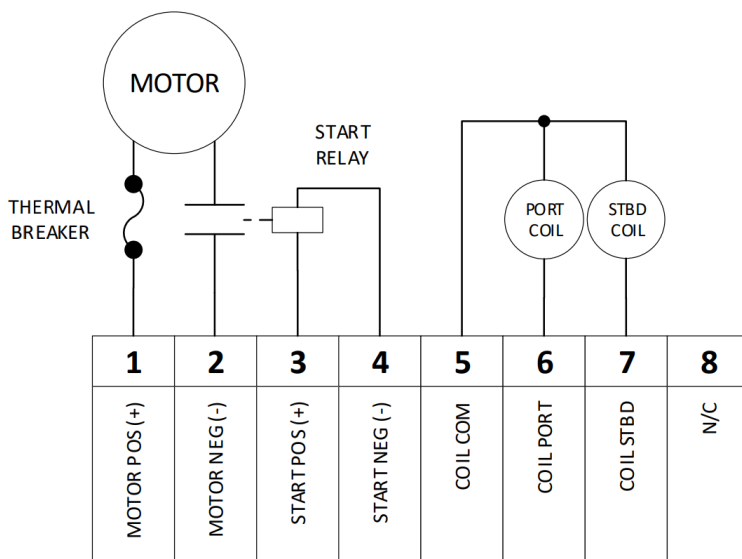

Figure 4: HPU100 Electrical Junction Box Internal Wiring

HPU100-12 contains a 30A Thermal Breaker.

HPU100-24 contains a 15A Thermal Breaker.

Table 2: HPU100 Terminal Block Wiring Connections

HPU100 Series			
Terminal #	Wire Name	Wire Colour	Function
1	MOTOR POS (+)	Red	Positive power supply to motor
2	MOTOR NEG (-)	Yellow (or Black)	Negative power supply to motor.
3	START POS (+)	Red	Positive control signal to starter relay to active motor and pump.
4	START NEG (-)	Yellow (or Black)	Control signal common (negative) to start relay to active motor and pump.
5	COIL COM	Green	Common Positive or Negative signal for solenoids coil control.
6	COIL PORT	Red	Positive or Negative signal for PORT direction solenoid coil.
7	COIL STBD	Black	Positive or Negative signal for STBD direction solenoid coil.
8	N/C	--	No Connection (N/C)

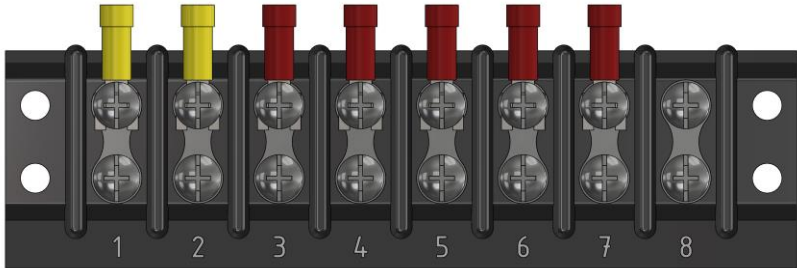

Figure 5: HPU100 Terminal Block Diagram

### 3.3.1 Example Connection Diagrams

The following section contains various example methods for connection of the HPU.

NOTICE	It is recommended that installation work is carried out by a Kobelt Partner, authorized service representative, or trained installation technician. Please contact the nearest Kobelt authorized distributor for assistance.
--------	--

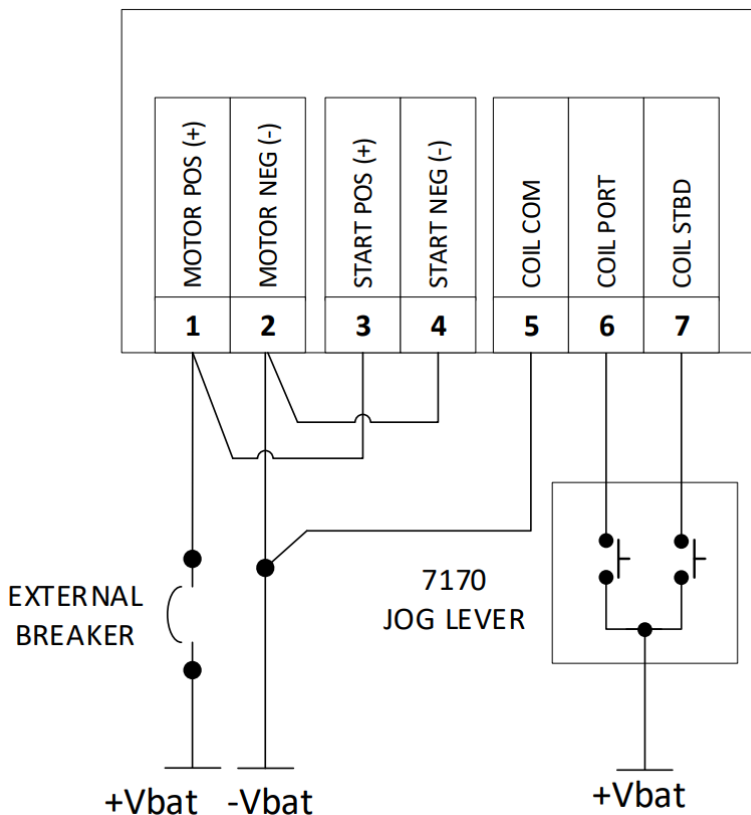

Figure 6: HPU100 Jog Control Diagram, Common Negative

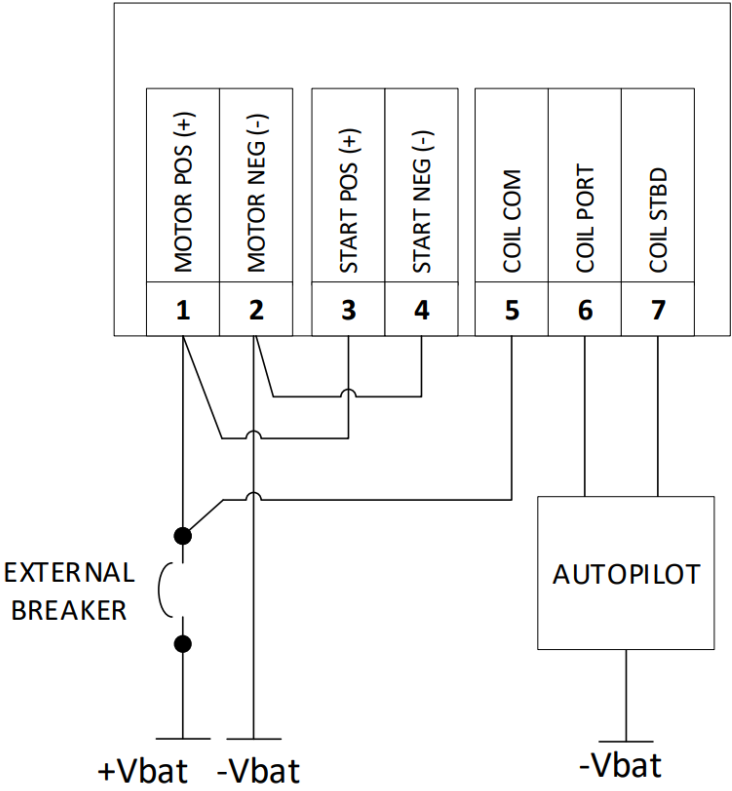

Figure 7: HPU100 Autopilot Wiring Diagram, Common Positive

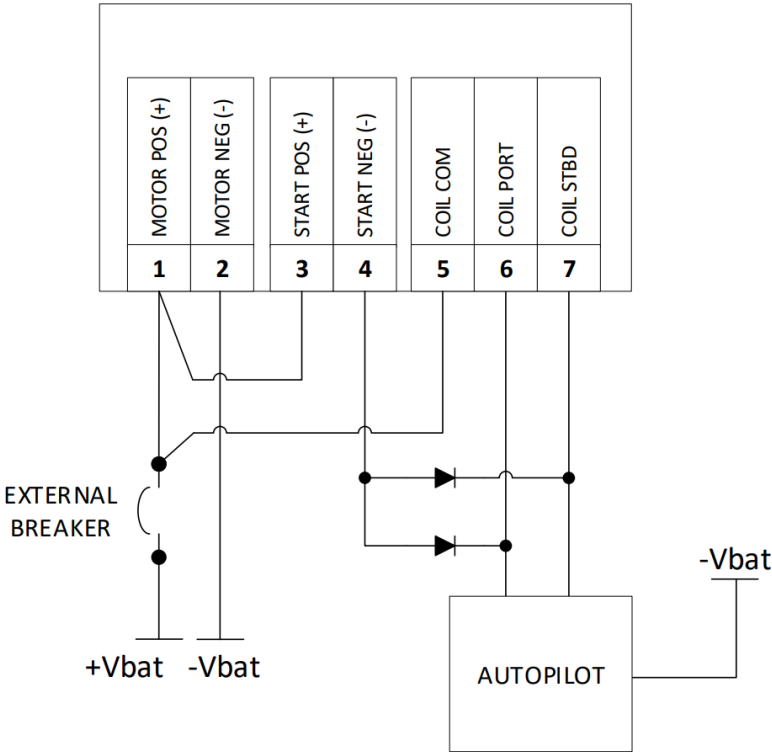

Figure 8: HPU100 Autopilot Connection Option with Starter Connections



## 4 COMMISSIONING

---

### 4.1 HYDRAULIC FILL & BLEED

After the hydraulic and the electrical connections have been completed, open all isolating valves and allow enough time for the pump and lines to fill with oil. Start the pump and operate the 4-way solenoid valve to check that the port and starboard directions are correct. If they are wrong, reverse connections to Terminals 6 and 7. Check the hard over to hard over speed of the rudder and adjust the flow for the appropriate speed. Clockwise to decrease and counter clockwise to increase.



#### **CAUTION**

The pressure relief is factory set at 500 psi and should not require adjustment.

### 4.2 ELECTRICAL CHECK



#### **CAUTION**

Ensure that the cover is installed and secured on the valve junction enclosure and all pigtail connections have been properly terminated and enclosed before powering on the HPU100.

Confirm that the electrical connections to the HPU100 have been made correctly and correspond to the requirements of your system installation.

### 4.3 FUNCTIONAL TEST



#### CAUTION

The Functional Test should be carried out while the vessel is still at dock and before it is taken out to sea, after installation has been completed.

After installation and filling, perform the following function tests:

1. Power ON the autopilot (or electronic jog lever).
2. Activate the autopilot (or electronic jog lever) to command motion.
3. Verify that the rudder position changed.
4. Set the autopilot to the manual mode and operate the pump-set to determine if the Port and Starboard directions are correct.
5. If the rudder goes the opposite way than expected.
  - a. Reverse the two electrical leads between the coils and the autopilot.

#### NOTICE

Most new autopilot systems will perform this test during their dockside set-up procedures.

6. Operate the pump-set and note the "hard-over" to "hard-over" (HO to HO) time.
7. Verify that it is in the range of 10 to 16 seconds. Times outside of this range indicate a mismatched pump-set for the steering system.

---

## 5 OPERATION

---

The HPU100 operates as follows:

- Manifold receives oil from pump, and outputs to steering lines. Output flow determining the speed of the rudder.
- Output flow is controlled by flow control valves.
- Pressure relief valve is factory set to approximately 500 psi.
- Excess flow is returned to tank via bypass valve.
- By energizing related solenoid on directional valve, flow will be sent to port or starboard.

---

## 6 MAINTENANCE

---

### 6.1 PREVENTATIVE MAINTENANCE

The brushes on the electric DC motor can be easily checked by removing the caps and visually inspecting the brushes. Replace the carbon brushes as required and check the internal condition of the motor. (see appendix E)

- Monthly (12 times per year)
  - Inspect connections for leaks.
- Quarterly (4 times per year)
  - Verify adequate oil level.
  - Visually inspect wire and cable insulation for splits or damage.
- Every (2) two years
  - Sample and analyze the oil in the steering lines.
  - Drain reservoir and clean out.

## 6.2 RECOMMENDED SPARE PARTS

As a minimum Kobelt recommends the following spare parts are on-hand:

*Table 3: Recommended Spares*

RECOMMENDED SPARES		
QTY	DESCRIPTION	KOBELT PART #
1	HPU100 REPAIR KIT (12 VDC / 24 VDC) <ul style="list-style-type: none"> <li>• Shaft Seal, O-rings, Motor Brushes and Caps</li> </ul>	600-031-RK

When purchasing spare parts refer to Appendix B: Parts List at the back of this manual for Kobelt component Part Numbers.

Instructions for installation of replacement components in Appendix E: Brush Replacement and Appendix F: Shaft Seal Replacement.

### NOTICE

It is recommended that any required service work on an Accu-Steer unit be performed by a factory authorized service representative. Please contact the nearest Kobelt authorized distributor for assistance.

## 7 TROUBLESHOOTING

If you encounter problems with the operation of your product, please refer to the troubleshooting suggestions before contacting Kobelt for assistance. If the steps below do not resolve your issue, please reach out either Kobelt directly or our Dealers in your area.

Table 4: Common Solutions

<b>Problem (Issue encountered)</b>	<b>Cause (What it means)</b>	<b>Corrective Action (What to do)</b>
<b>Steering gear goes hard over</b>	Short circuit in electrical wiring to solenoid	Test wiring and solenoid valve coils.
	Solenoid valve contaminated	Isolate lines, clean and/or repair the solenoid valve as required.
<b>Steering gear does not respond</b>	Solenoid not being energized	Manually operate the solenoid valve.
	Bypass valve is open	<ol style="list-style-type: none"> <li>1. Check if bypass valve opens due to contamination.</li> <li>2. Check if flow valve open</li> <li>3. Check drive coupling</li> </ol>
<b>Pump is noisy</b>	Air is in the system	Fill and bleed the hydraulic system to remove air.
<b>Motor is running but not making pressure</b>	Motor direction is not correct	Reverse motor wires.

---

## 8 WARRANTY

---

Kobelt Manufacturing Co. Ltd. ("Kobelt") warrants the Products and Parts manufactured by Kobelt to be free from defects in workmanship or material and that said products are designed mechanically and functionally to perform to specifications.

This warranty is effective providing:

- The equipment is used within the intended operating conditions and in accordance with Kobelt recommendations
- The equipment is installed according to equipment diagrams, specifications and recommendations which Kobelt has provided

This warranty becomes invalid if the factory supplied serial number has been removed or altered on the product. This warranty does not cover cosmetic damage or damage caused by an act of God, accident, misuse, abuse, negligence or modification of any part of the product. This warranty does not cover damage due to improper operation or maintenance, connection to inappropriate equipment or attempted repair by anyone other than an authorized Kobelt representative.

Upon identification of a potential issue or defect with a Kobelt Product or Part, the Warranty Applicant ("Applicant") must immediately contact Kobelt and describe the issue in writing, by letter, fax, email or other electronic conveyance. Kobelt will then assess the cause of the defect and determine warranty applicability and appropriate remediation.

If any part is found to be defective, Kobelt will replace said part FOB the Kobelt factory provided that any such defective part is returned by the Buyer with freight and applicable forwarding charges prepaid by the Buyer. Kobelt's sole obligation to the Applicant will be to repair or replace the defective part with same or similar product, to a maximum value of the list price of the product or part. The Kobelt warranty does not cover labour charges, travel or any other associated expenses.

All Products and Parts manufactured by Kobelt, are subject to a warranty against manufacturer's defects in materials or workmanship for a period of two (2) years from the date of purchase.

Kobelt will be responsible for all Products or Parts sold by Kobelt but manufactured by 3<sup>rd</sup> party manufacturing companies. However, these products and parts are subject to applicable 3<sup>rd</sup> party warranties and may not be the same as the Kobelt warranty.

# 9 APPENDIX A: INSTALLATION DIMENSIONS

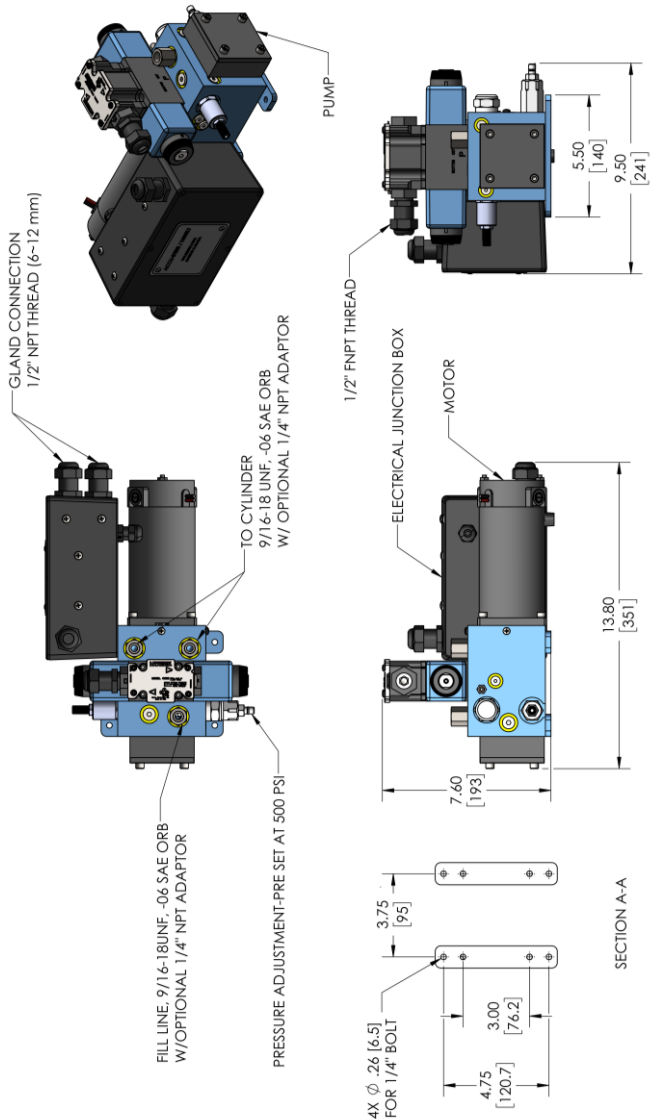

Figure 9: HPU100 Installation Dimensions



# 10 APPENDIX B: PARTS LIST

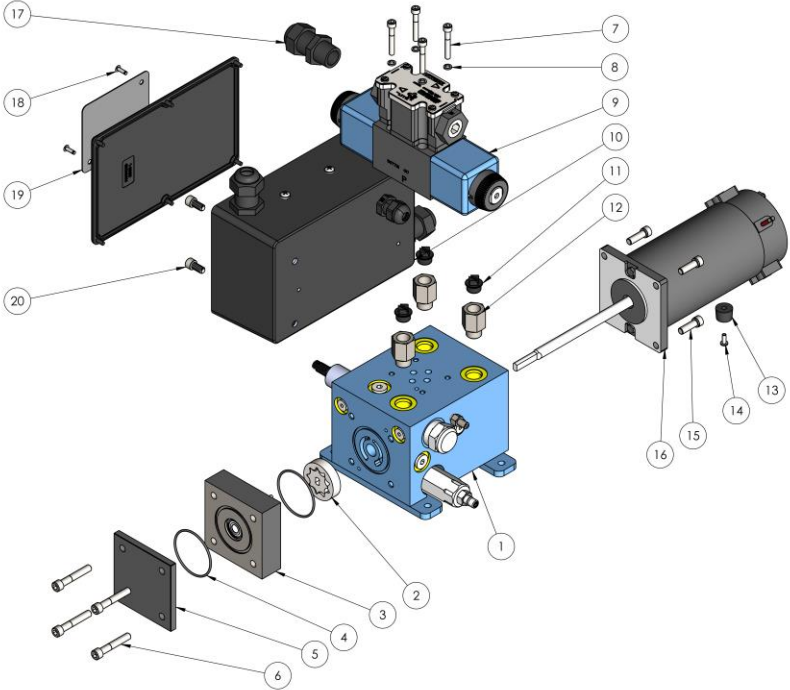

Figure 10: HPU100 Parts Diagram

Table 5: HPU100 Parts List

			Model No.:	HPU100-12	HPU100-24
			Part No.:	600-031	600-032
ITEM	QTY	DESCRIPTION			
1	1	MANIFOLD	502-110		
2	1	GEROTOR	7250-0004		
3	1	PUMP HOUSING SUB ASSEMBLY	502-115		
4	2	O-RING	600-031-RK*		
5	1	PUMP END COVER PLATE	7001-0042		
6	2	SCREW CAP SKT HD, 1/4-20 X 1 1/2	1002-1024		
7	4	SCREW SKT HD SS, 10-24 x 1-1/4	1002-0820		
8	4	LOCK WASHER, HIGH COLLAR, #10, SS	1023-0408		
9	1	DIRECTIONAL VALVE	7036-0012	7036-0013	
10	1	ELECTRICAL BOX; HPU 100, 12VDC/30A	503-017	503-018	
11	3	PLASTIC PLUG, 1/4 NPT	7039-3042		
12	3	FITTING, -06 ORB M x 1/4 NPT F	7039-0141		
13	1	RUBBER FOOT	7056-0052		
14	1	SCREW, PAN HD, PHL, #6-32 x 3/8	1012-0606		
15	4	SCREW CAP SKT HD 1/4UNC X3/4 GR	1002-1012-2		
16	1	ELECTRIC MOTOR, 1/2HP, DC	7070-0013	7070-0014	
17	1	CABLE GLAND, 1/2 NPT, .27 - .48 CORD, NYLON	6009-7840		
18	2	RIVET 1/8 IN, NAIL TYPE BLIND	1032-0420		
19	1	HPU NAMEPLATE	7001-100		
20	2	FLAT HD SOCKET CS, 1/4-20 x 1/2	1015-1008		
21	3	WIRE JOINT, NYLON INS 2#22 - 2#16AWG	6009-6601		

\* Part included in standard repair kit. Not sold separately.

# 11 APPENDIX C: MANIFOLD ASSEMBLY PARTS

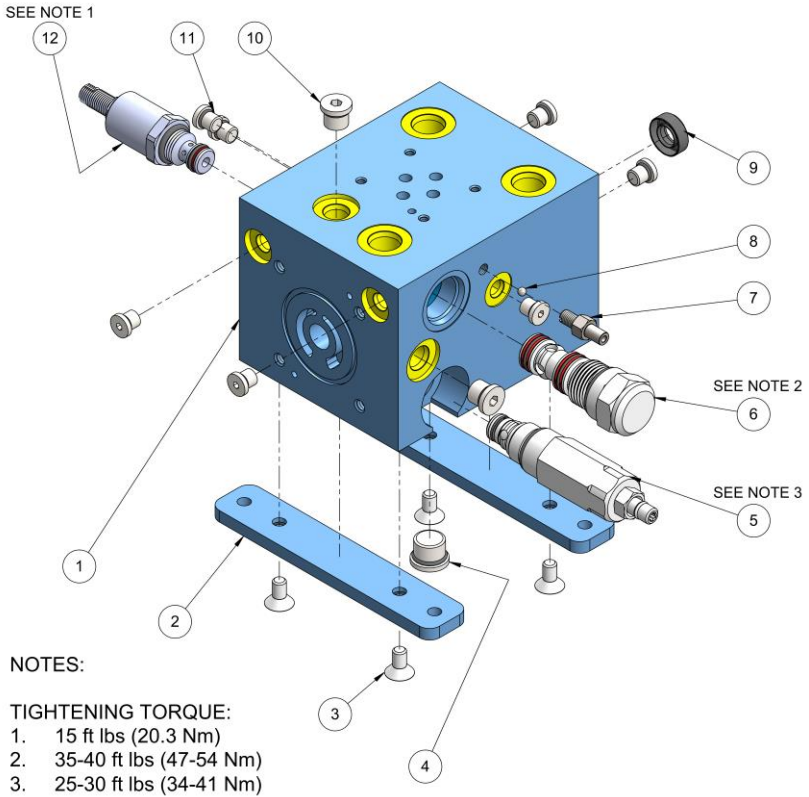

Figure 11: 502-110 Manifold Parts Diagram

Table 6: HM100 Manifold Parts Table

			Part No.:	502-406
ITEM	QTY	DESCRIPTION		
1	1	HPU100 BLOCK		220-335
2	2	HRP 35 FOOT MOUNT BRACKET		7057-0014
3	4	FLAT HD SOCKET CS, 1/4-20 x 1/2		1015-1008
4	1	PLUG, -06 ORB		7039-0662
5	1	RELIEF VALVE		7043-0008
6	1	DIFFERENTIAL PRESSURE SENSE VALVE		7046-0002
7	1	BLEEDER SCREW		7040-0011
8	1	BALL		1301-0005
9	1	SHAFT SEAL		600-031-RK*
10	2	PLUG, -04 ORB		7039-0661
11	7	PLUG, -02 ORB		7039-0660
12	1	FLOW CONTROL		7044-0012

\* Part included in standard repair kit. Not sold separately.

# 12 APPENDIX D: ELECTRICAL BOX ASSEMBLY PARTS

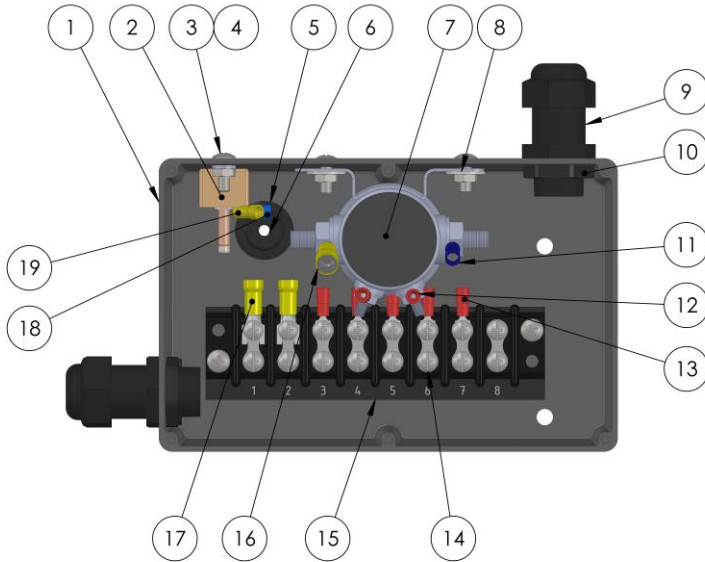

Figure 12: ELECTRICAL BOX

Table 7: Electrical Box HPU 200-12VDC Parts Table

			Part No.:		503-019	
ITEM	QTY	DESCRIPTION				
1	1	JUNCTION BOX; HPU 200	300-010-5			
2	1	CIRCUIT BRKR. 30 AMPS AT 12 VDC	301-030	6009-8108		
3	6	SCREW, PAN HEAD, #10 UNC X ½, GR 18-8	1012-0808			
4	4	NUT, HEX, #10-24, 18-8 SS	1022-0108			
5	1	NUT, CABLE GLAND, 3/8NPT	302-063			
6	1	CABLE GLAND, 3/8 NPT, 3.5-8mm CABLE, PA	302-053			
7	1	RELAY STARTER SPST 12VDC 85ADC CONT. BRACKET MOUNT	6010-1607	6010-1608		
8	2	WASHER FLAT 1/4IN 18-8	1023-0110			

<b>9</b>	3	CABLE GLAND, 1/2 NPT, .27 - .48 CORD, NYLON	6009-7840
<b>10</b>	3	NUT, CABLE GLAND, 1/2 NPT	302-064
<b>11</b>	1	TERMINAL - RING; INS VYL; 5/16in; 14-16 AWG; BLUE	6009-6415
<b>12</b>	2	TERM RING INS VYL #10 18-22AWG RED	6009-6403
<b>13</b>	6	TERM FORK INS VYL #8 18-22AWG RED	6009-6452
<b>14</b>	1	TERM BLOCK 8POS 30A 250V	6009-0014
<b>15</b>	1	TERM LABEL 8POS	6009-0015
<b>16</b>	1	TERM RING INS VYL 5/16IN, 10-12 AWG	6009-6425
<b>17</b>	2	SPADE TERMINAL #10 YEL, 10-12AWG	6009-6473
<b>18</b>	1	TERM RING INS VYL #10 14-16AWG BLU	6009-6413
<b>19</b>	1	TERM RING INS VYL #10 10-12AWG YEL	6009-6423
<b>20</b>	18*	CABLE; 4C/18AWG, SOW EXT CABLE	302-105

\*Cable unit expressed in inches

# 13 APPENDIX D: TYPICAL SYSTEM ARRANGEMENT

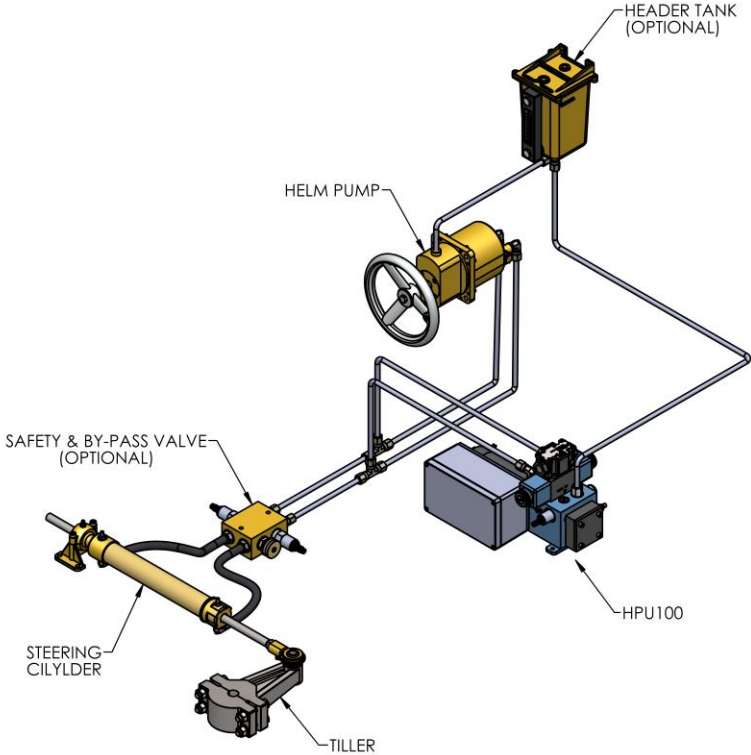

Figure 13: Typical System Arrangement

## 14 APPENDIX E: BRUSH REPLACEMENT

### Steps for Replacement of Motor Brushes:

1. Remove the brush caps. (Replacement kit includes new caps for installation).
2. Remove the brushes.
3. Inspect the brushes for wear.
4. If replacement required.
  - a. Remove them with consideration to the direction of brushes.
  - b. Install new brushes in proper orientation.
  - c. Put the brush caps in right place.
5. If replacement not required.
  - a. Re-assemble using new brushes and caps from repair kit.

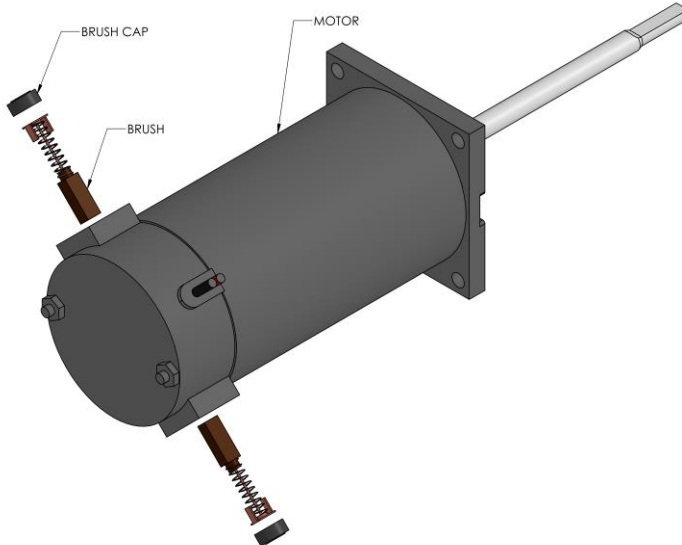

Figure 14: Motor Brush Diagram



## 15 APPENDIX F: SHAFT SEAL REPLACEMENT

### Steps for Replacement of Motor Shaft Seal:

1. Clean both the Bore and Seal thoroughly with Methyl Hydrate or Similar Degreaser
2. Apply thin film of Loctite 567 (Liquid Teflon) to the Bore and Seal
3. Using moderate force, drive Seal into bottom of Bore using seating tool.

**Note:** Installation force is often provided solely by hand-operated arbor presses or soft-faced mallets (used in conjunction with strike plates).

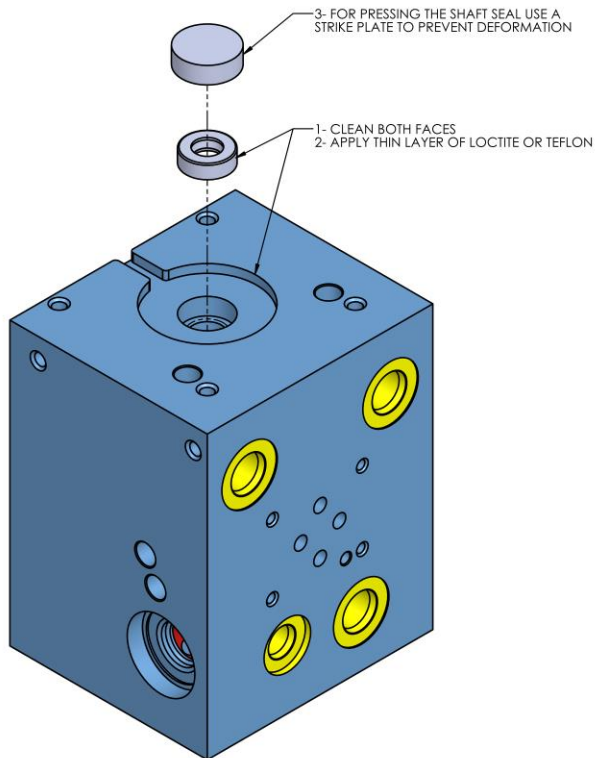

Figure 15: Motor Shaft Seal Diagram

# ***KOBELT***

**Kobelt Manufacturing Co. Ltd.**

8238 129th Street  
Surrey, British Columbia,  
Canada, V3W 0A6

Sales Tel: +1-604-572-3935

Fax: +1-604-590-8313

Email: [sales@kobelt.com](mailto:sales@kobelt.com)

Website: [www.kobelt.com](http://www.kobelt.com)

Made in Canada / Printed in Canada