KOBELT

5430 SERIES ENCLOSED
BRAKE
AIR APPLIED VERSION

*Owner's Operation, Installation &
Maintenance Manual*

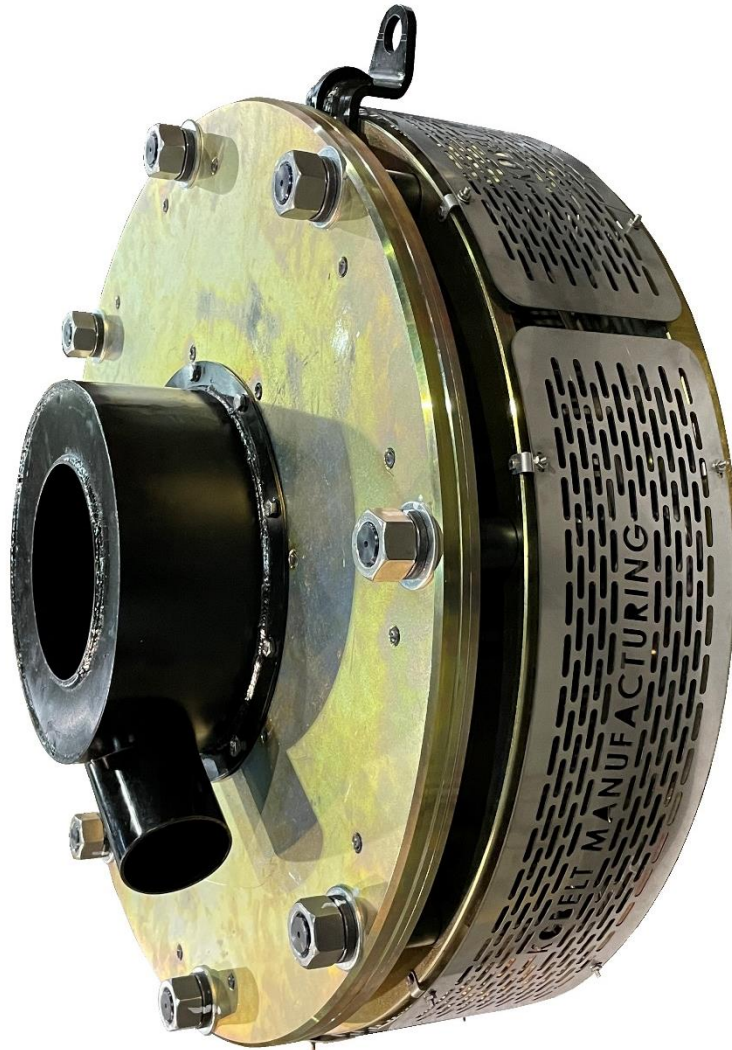

Table of Contents

1	Introduction	4
1.1	Contact Information.....	4
1.2	Safety Information	4
1.2.1	Safety Instructions	4
1.2.2	Hazards	5
1.3	Product Description	6
1.4	Technical Data.....	7
1.5	Model Code Key	7
2	Installation	8
2.1	Preparation	8
2.2	Brake Hub.....	8
2.3	Brake	8
2.3.1	Mechanical.....	8
2.3.2	Piping	9
2.4	Cooling Fan.....	9
3	Commissioning	10
3.1	Function Test.....	10
3.2	Burnishing	10
3.3	Torque Test	11
4	Operation	12
4.1	Functional Requirements.....	12
4.1.1	Pressure Supply	12
4.2	Service Limits	12
4.2.1	Disc Temperature	12
4.2.2	Ambient Temperature	12
4.2.3	Pressure	12
4.2.4	Disc speed.....	12
5	Maintenance	13
5.1	Preventative Maintenance.....	13
5.2	Inspection.....	13
5.2.1	Pad Wear	13
5.2.2	Seals.....	13
5.2.3	Brake Disc	13
5.3	Service.....	14
5.3.1	Tool List.....	14
5.3.2	Brake Linings.....	14
5.3.3	Actuators	15
5.4	Recommended Spares	17

6	Warranty	18
7	Appendix A: Technical Drawings.....	19
8	Appendix B: Parts List Drawings	20

1 INTRODUCTION

1.1 CONTACT INFORMATION

Kobelt Manufacturing Co. Ltd.
8238 129th Street
Surrey, British Columbia
Canada, V3W 0A6

Sales Tel: +1-604-572-3935
Fax: +1-604-590-8313
Email: sales@kobelt.com
Website: www.kobelt.com

For further instructions, please contact our distributors or visit our website.

1.2 SAFETY INFORMATION

1.2.1 Safety Instructions

Notice to Installer:

Disregarding the following safety measures can result in an accident causing severe injury to personnel and damage to material assets:

- Only use the product as directed in this manual.
- Never put the product into service if there is evidence of visible damage.
- Never put the product into service before fully completing installation and commissioning.
- Do not carry out any modifications to the product.
- Only use authentic Kobelt spare parts.
- Observe all local regulations, directives and laws during the installation of this product.
- All installation, commissioning and maintenance work must only be conducted by qualified personnel. (For the purpose of this manual, qualified personnel are persons who are familiar with the assembly, installation, commissioning, and operation of the product and who have the qualifications necessary for their occupation.)
- Observe all specifications in this manual. If these guidelines are not followed and damage occurs, the warranty will be voided.

1.2.2 Hazards

Throughout this publication, Warnings and Cautions accompanied by the International Hazard Symbol  is used to alert the user to special instructions concerning a particular service or operation that may be hazardous if performed incorrectly or carelessly.

 DANGER	Equipment Starts Automatically: Brake systems frequently are controlled remotely and may activate suddenly causing bodily harm. Ensure all power sources are locked out prior to performing work.
---	---

 WARNING	Pinch Points: Brakes contain numerous pinch points which can cause serious injury. Ensure all power sources are locked out prior to performing work.
--	--

 WARNING	High Pressure Fluids: Kobelt brakes use compressed air. Ensure all pressure is exhausted and the pressure source locked out prior to performing work.
--	---

 WARNING	Hot Surfaces: Disc brakes are capable of making the surfaces of the brake disc dangerously hot when burnishing or during braking events. Ensure the disc is adequately guarded to prevent inadvertent contact with the disc.
--	--

SAFETY INSTRUCTIONS	Airborne Dust: Brake linings contain fibers that may become airborne during cutting or sanding operations. Over exposure to these dusts should be considered hazardous. Use NIOSH approved respirators when working with brake linings. Request a MSDS for further information.
----------------------------	---

1.3 PRODUCT DESCRIPTION

The diagram below shows a typical Kobelt enclosed brake with all the major components identified.

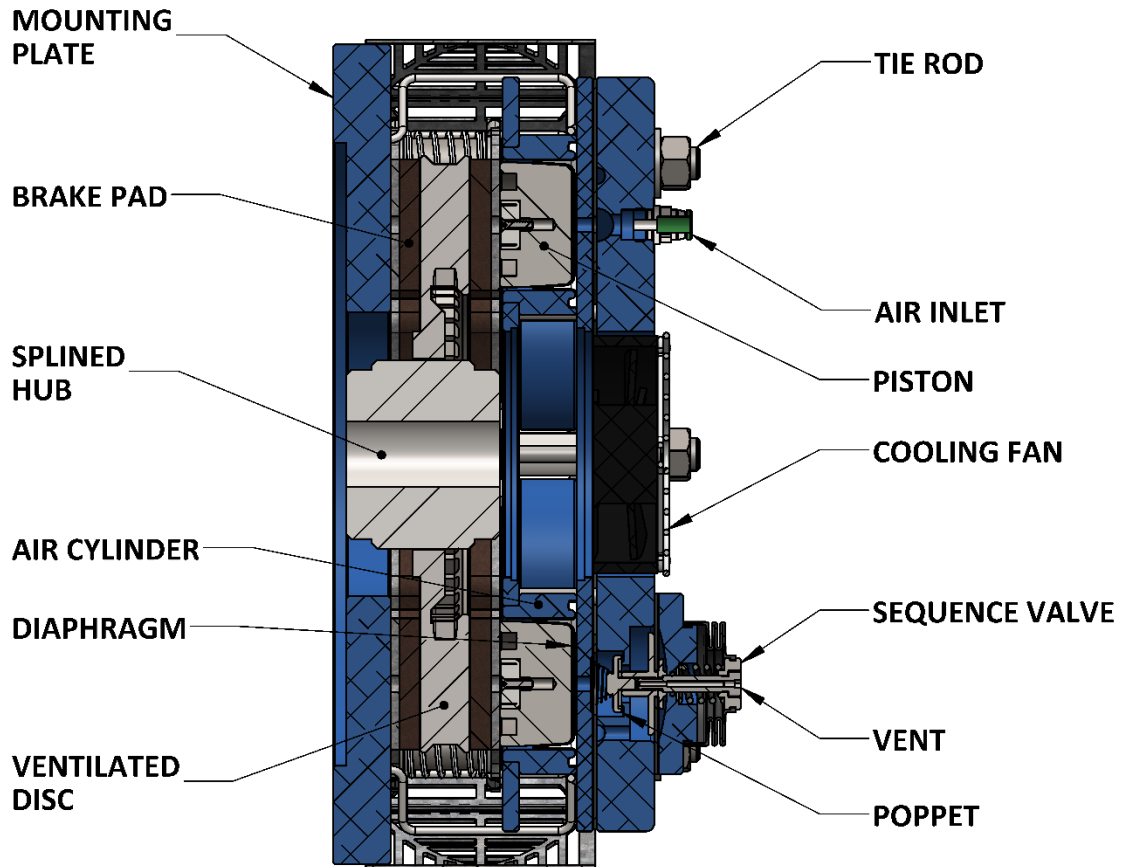

Figure 1: Tension Brake Nomenclature

1.4 TECHNICAL DATA

For technical data and specifications refer to the relevant data sheets from www.kobelco.com or the technical drawings in Appendix A if provided.

Model no.:	5430-A-G	
1. Maximum Torque:	20,500 ft-lbs	[27.8 kNm]
2. Pad Life:	78,800 hp-hr	[58,800 kw-hr]
3. Maximum Speed:	875 rpm	
4. Thermal Performance:		
4.1. Cooling:	80 hp	[60 kw]
4.2. Required Air Flow:	840 cfm	[1427 cmh]
4.3. Heat Sinking:	55 hp-sec/F	[74 KJ/C]
5. Maximum pressure:	100 psi	[6.9 bar]
6. Volume:		
6.1. Normal:	70 in ³	[1.1 L]
6.2. Maximum:	255 in ³	[4.2 L]
7. Weight:	1512 lbs	[686 kg]
8. Rotating Inertia:	339 lbs-ft ²	[4.3 kgm ²]

1.5 MODEL CODE KEY

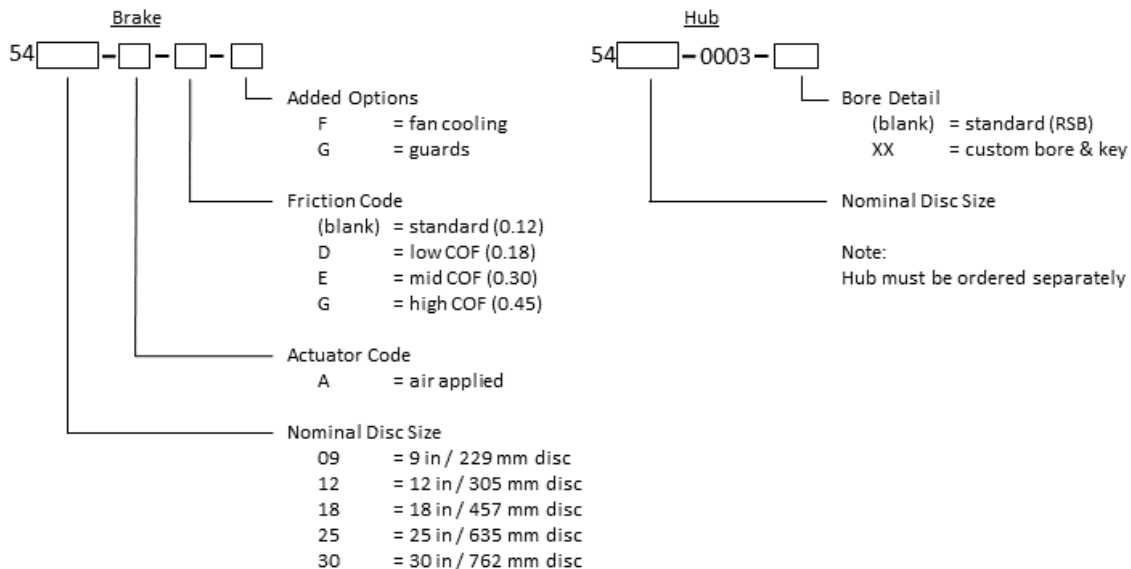

2 INSTALLATION

2.1 PREPARATION

The mounting bracket to support the brake must be designed to withstand the maximum braking forces generated by the brake. The bracket must meet the following requirements:

Flatness:	.005 in [.13 mm] ⁽¹⁾
Pilot fit:	27.369/27.361 in [695.1/694.9 mm] ²

- (1) Allowable deviation from flatness is proportional to the bolt circle diameter with an IT8 tolerance grade. See Appendix A for key installation dimensions.
- (2) The locating pilot on the mounting plate should provide the brake with an LC7 fit (H10/e9).

The rotating element should have bearings suitably rated to carry the weight of the disc and hub. The run-out of the shaft must not exceed .012 in [.30 mm] TIR.

Actuator ports are plugged to prevent contamination. Remove the plugs prior to connection to the piping.

For cases where a guard or some protective cover is required ensure that the guard does not compromise the performance. An improperly designed cover or shield may cause air recirculation through the disc or radiant heat reflection, which could result in the disc overheating. The cooling air pumped through the disc must be exhausted away from the outer diameter of the disc to allow fresh, cool air to enter the inner vent opening of the disc.

2.2 BRAKE HUB

The brake hub must be installed onto the shaft before installing the brake. Insert the shaft key and tighten the two set screws to 500 in-lbs [57 Nm] using a 1/4 inch hexagon key.

2.3 BRAKE

2.3.1 Mechanical

Perform the following steps to properly install a 5400 series brake:

1. Ensure that both mounting faces of the brake and the mating surfaces on the bracket are clean.
2. Lubricate the hub splines with a light coat of EP grease containing 4% MoS₂
3. Align the splines on the disc with those on the hub and insert the brake over the hub.
4. Install the SAE grade 5 mounting bolts. It is recommended to use a thread locking product such as Loctite® to ensure a vibration resistant and secure joint.
5. Tighten the mounting bolts to 113 ft-lbs [153 Nm].

2.3.2 Piping

The piping to the brakes must be adequately sized to ensure appropriate response times. The piping must be selected to safely withstand the pressures required to operate the brakes. Secure the piping every 3 ft [0.9 m] against vibration with pipe clamps.

All piping must be cleaned prior to connection to the brake. Welded carbon steel piping must be pickled to remove the scale produced by welding.

The brake is equipped with a 3/4 NPT pressure port. The connections to the brake actuators must be made by hoses of a suitable rating to accommodate deflection of the brake.

NOTICE

Do not over tighten the fitting in the actuator port as damage to the actuator may occur.

For operation in sub-zero temperatures down to a minimum of 0°F [-20°C] the air must be dried to a dew point of -50°F [-44°F]

WARNING

Failure to adequately dry the compressed air supply may result in the brake valve freezing and rendering the brakes inoperable in sub-zero weather conditions.

2.4 COOLING FAN

The brake may be supplied with a cooling fan. The supplied cable length is 51 in [1.3 m] – ensure that a motor feed junction box is placed within reach. Connect the motor leads as shown in the diagram below. Ensure that the motor voltage is correct and that a starting capacitor is installed for single phase fan motors.

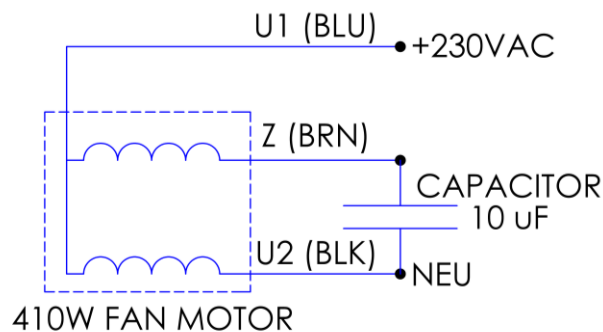

Figure 2: 230VAC Fan Wiring

3 COMMISSIONING

3.1 FUNCTION TEST

Before burnishing the brakes perform a quick inspection and function test of the brakes:

- (1) Ensure that all mounting bolts are properly installed.
- (2) Ensure the brake disc surface is clean. Remove all contamination from the disc with cleaning solvent.
- (5) Check that the pressure source is within the specified pressure range.
- (6) Check that all bolts are tight.
- (7) Cycle the brakes and ensure that the brakes are operational

3.2 BURNISHING

Burnishing is required to achieve rated brake torque. The process of burnishing removes minor contaminants from the rubbing surfaces and improves the degree of contact between the brake pad and disc.

If present, safety interlocks of the drive mechanism should be temporarily defeated to allow the disc to be driven with the brake partially applied.

Extreme care must be taken not to overheat the disc during the process.

 WARNING	Disc temperature must not exceed 700°F (371°C) or permanent degradation of the lining may occur.
--	--

Burnishing is best achieved by applying the maximum torque and minimum speed that the drive can tolerate. Depending on the configuration of the brake system it may be necessary to reduce the burnishing torque by;

- a) Partially applying the brake with fluid pressure to a level that the drive can tolerate, or
- b) In systems with more than one brake, isolate all but one brake and burnish one brake at a time.

Three important points to consider when burnishing is;

- i. The temperature of the disc must be closely monitored. Excessive heat will damage the friction linings.
- ii. The duration of burnishing varies with each application.
- iii. Burnishing is not complete until the brake is producing rated torque. This will be indicated by the motor current while burnishing.

**WARNING**

Failure to properly burnish will not allow the brake to produce adequate torque for the intended duty.

3.3 TORQUE TEST

Before putting equipment into service, confirm that full rated braking torque has been achieved through load testing or a torque test against the drive motors. If full brake torque has not been achieved, continue burnishing.

4 OPERATION

4.1 FUNCTIONAL REQUIREMENTS

4.1.1 Pressure Supply

It is necessary to size air compressors and storage tanks to provide sufficient air for the intended duty of the brakes.

The main supply line to the brake system should be equipped with a filter, and regulator. The filter's function is to remove moisture and dirt in the system and the regulator will provide a constant air pressure to the control system. If the brake system is operating in sub-zero temperatures, it is recommended to have an air dryer in the system to remove all moisture. Alternatively, a lubricator can be filled with methyl hydrate (wood alcohol) to prevent freezing of the air system.

4.2 SERVICE LIMITS

4.2.1 Disc Temperature

The Kobelt brake lining achieves maximum friction at 300°F. Over 300°F the brake begins to fade or experience diminishing friction. The maximum operating temperature of the brake linings is 700 °F [371° C]. Temperatures in excess of this limit will permanently damage the linings and require replacement.

4.2.2 Ambient Temperature

The operating temperature range of the brake is -35°C [-31°F] to 50°C [122°F]

4.2.3 Pressure

Do not allow the supply pressure to exceed 100 psi. If the available supply pressure exceeds the maximum allowable working pressure, then some form of a pressure regulator is required. The pressure supply system must be equipped with a safety relief valve.

4.2.4 Disc speed

The potential imbalance in the ventilated disc could be detrimental to rotating equipment at high speeds. For running speeds greater than the values listed in the technical data section the discs must be balanced. Under no circumstances must the running speed exceed this value.

5 MAINTENANCE

5.1 PREVENTATIVE MAINTENANCE

Maintenance Schedule

Maintenance Item	Daily	Monthly	Annually	5 years
Inspect for leaks		✓		
Determine pad life		✓		
Inspect brake disc				✓
Service Actuators				✓

5.2 INSPECTION

5.2.1 Pad Wear

The maximum allowable pad life has been reached when the brake pad has worn down to 1/16" [1.5 mm] thick. The lining must be replaced before the backing plate makes contact with the brake disc.

5.2.2 Seals

The actuator seals should be inspected on a periodic basis. Apply air pressure to the actuators and listen for any hissing sound that would indicate a torn or ruptured diaphragm.

5.2.3 Brake Disc

The brake disc must be inspected periodically to monitor the condition of the braking surface. When the condition of the braking surface has deteriorated to the point that the quality requirements below are no longer met the disc must be removed and resurfaced or replaced.

Axial Run out:	.020 in [.50 mm] TIR
Flatness:	.010 in [.25 mm]
Surface Finish:	63 micro inches [1.6 micrometers] RMS

Follow the minimum thickness allowances in the table below as a guideline for when a disc must be replaced.

Table 1: Brake Disc Minimum Thickness Allowances

Brake Disc Minimum Thickness		
Disc Series	Original Thickness in [mm]	Minimum Thickness in [mm]
4.00-07-XX	4.00 [101.2]	3.88 [98.6]

NOTICE

When re-machining the disc surface, equal amounts must be taken off of each face.

5.3 SERVICE

5.3.1 Tool List

The following tools are required for servicing the 5430-A tension brake:

- | | |
|--------------------------------|----------------------------------|
| 1. 1-7/8 inch socket or wrench | actuator removal / installation |
| 2. Pliers | brake pad removal / installation |
| 3. 3/8 inch hex bit | actuator disassembly / assembly |
| 4. 11/32 inch wrench | guard removal / installation |
| 5. Torque wrench, | brake assembly |

5.3.2 Brake Linings

The linings must be replaced before the backing plate makes contact with the disc. When replacing the brake pads follow these steps;

1. Remove the guards by removing the four hex nuts using a 11/32 wrench.



2. Starting with the mounting flange side pads first, push the pad retainer out of engagement with the backing plate. It may be necessary to use a brake spring plier or a screw driver.

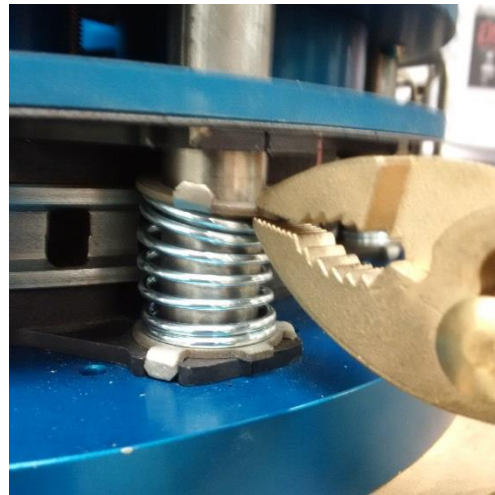

3. While holding the return spring compressed, slide the shoe radially outward. Repeat with the other retainer and lift the pad away.

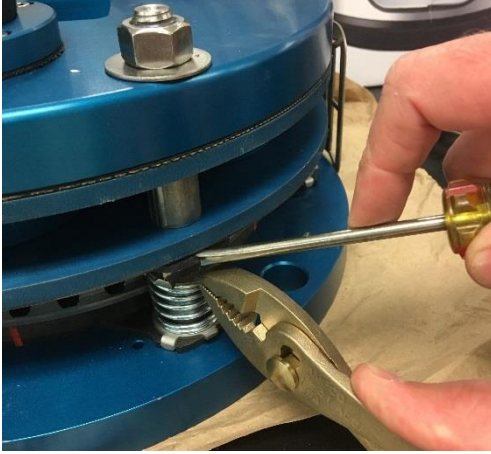

4. Remove all six pads on the mounting flange side.
5. Slide the disc towards the mounting face of the brake.
6. Repeat steps 2 & 3 with the actuator side pads.
7. Install the new brake pads by starting with the actuator side first. Ensure that all pad retainers are engaged with the backing plate.

5.3.3 Actuators

To replace the actuator diaphragms and seals the actuator sub-assembly must be removed from the brake assembly. Follow the steps below:

1. Place the manifold plate top side down and install the two large O-rings.
2. Place the actuator cover on top. Ensure that the cylinder recesses are facing upwards, and the stud holes are aligned.

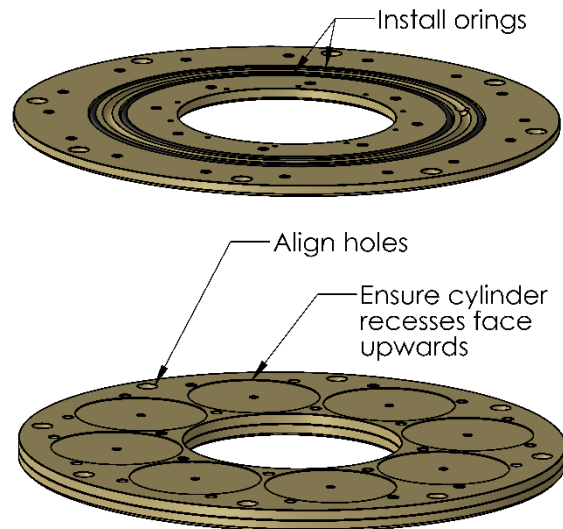

3. Install the eight cylinders with the O-ring seal centered in the recesses.

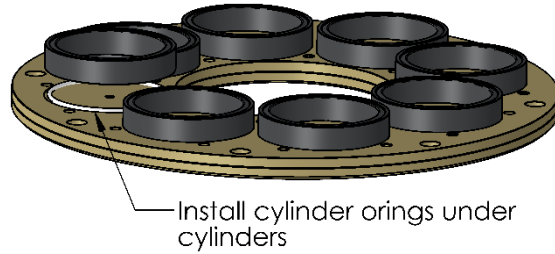

4. Install the piston assemblies ensuring that the diaphragm bead sits fully in the groove on the cylinder end face.

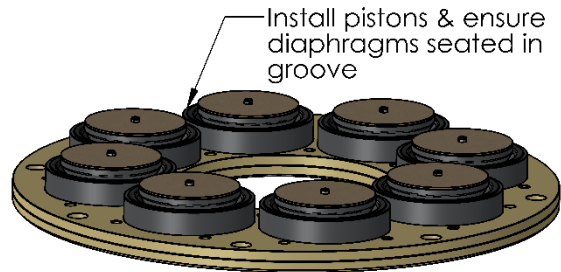

5. Carefully lower the magazine plate over top of the piston assemblies. Ensure all the screw holes are aligned. Install the flat head screws finger tight.

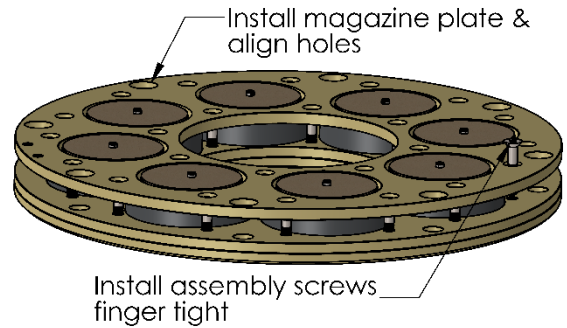

6. Tighten the twenty-four flat head screws using a 3/8 inch hex bit;
 - a. Follow the pattern noted below:

Set	Bolts
1	1 -> 9 -> 19
2	23 -> 5 -> 13
3	3 -> 11 -> 18
4	22 -> 15 -> 7
5	12 -> 4 -> 20
6	24 -> 6 -> 14
7	2 -> 10 -> 17
8	21 -> 8 -> 16

- b. Progress to the final torque value in two steps starting with 56 ft-lbs [76 Nm].
 - c. Final torque value for the assembly screws is 112 ft-lbs [152 Nm].

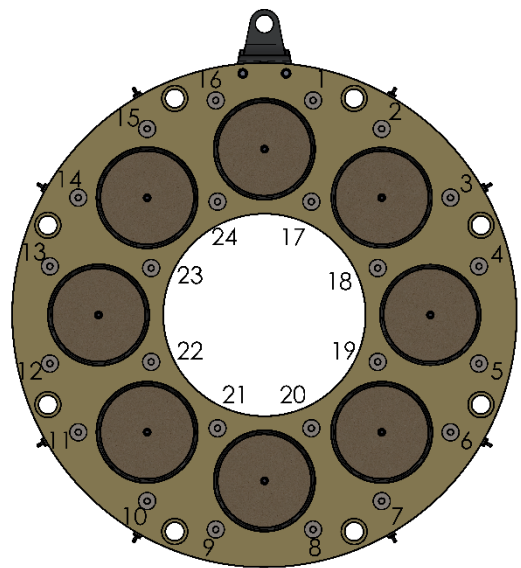

-
7. Install the actuator onto the brake and tighten the eight nuts to 750 ft-lbs [1017 Nm].

5.4 RECOMMENDED SPARES

The spare parts kept on hand will depend on the severity of the service. As a minimum Kobelt recommends keeping the following parts for each brake in service:

1. One Lined set of brake shoes
 - a. See below
2. One complete set of diaphragms and seals
 - a. 5430-RK

Refer to the parts list drawings in [Appendix B](#) for a complete list of parts.

The table below itemizes which kit/spare part numbers change with the various brake configuration options. Please reference this table to ensure you receive the correct parts.

Table 2: Configuration Kit Numbers

Configuration Kit Numbers		
Friction Code	Lined Shoe	Friction Material
(blank)	5430-LSC	low COF (.12-.15)
-D	5430-LSD	low COF (.17-.20)
-E	5430-LSE	mid COF (.25-.28)
-G	5430-LS	high COF (.40-.45)

6 WARRANTY

Kobelt Manufacturing Co. Ltd. (“Kobelt”) warrants the Products and Parts manufactured by Kobelt to be free from defects in workmanship or material and that said products are designed mechanically and functionally to perform to specifications.

This warranty is effective providing:

- The equipment is used within the intended operating conditions and in accordance with Kobelt recommendations
- The equipment is installed according to equipment diagrams, specifications and recommendations which Kobelt has provided

This warranty becomes invalid if the factory supplied serial number has been removed or altered on the product. This warranty does not cover cosmetic damage or damage caused by an act of God, accident, misuse, abuse, negligence or modification of any part of the product. This warranty does not cover damage due to improper operation or maintenance, connection to inappropriate equipment or attempted repair by anyone other than an authorized Kobelt representative.

Upon identification of a potential issue or defect with a Kobelt Product or Part, the Warranty Applicant (“Applicant”) must immediately contact Kobelt and describe the issue in writing, by letter, fax, email or other electronic conveyance. Kobelt will then assess the cause of the defect, and determine warranty applicability and appropriate remediation.

If any part is found to be defective, Kobelt will replace said part FOB the Kobelt factory provided that any such defective part is returned by the Buyer with freight and applicable forwarding charges prepaid by the Buyer. Kobelt’s sole obligation to the Applicant will be to repair or replace the defective part with same or similar product, to a maximum value of the list price of the product or part. The Kobelt warranty does not cover labour charges, travel or any other associated expenses.

All Products and Parts manufactured by Kobelt, with the exception of brake discs and pads, are subject to a warranty against manufacturer’s defects in materials or workmanship for a period of two (2) years from the date of purchase. Brake discs are subject to a one (1) year warranty period, and brake pads and linings are not covered by warranty.

Kobelt will be responsible for all Products or Parts sold by Kobelt but manufactured by 3rd party manufacturing companies. However, these products and parts are subject to applicable 3rd party warranties, and may not be the same as the Kobelt warranty.

7 APPENDIX A: TECHNICAL DRAWINGS

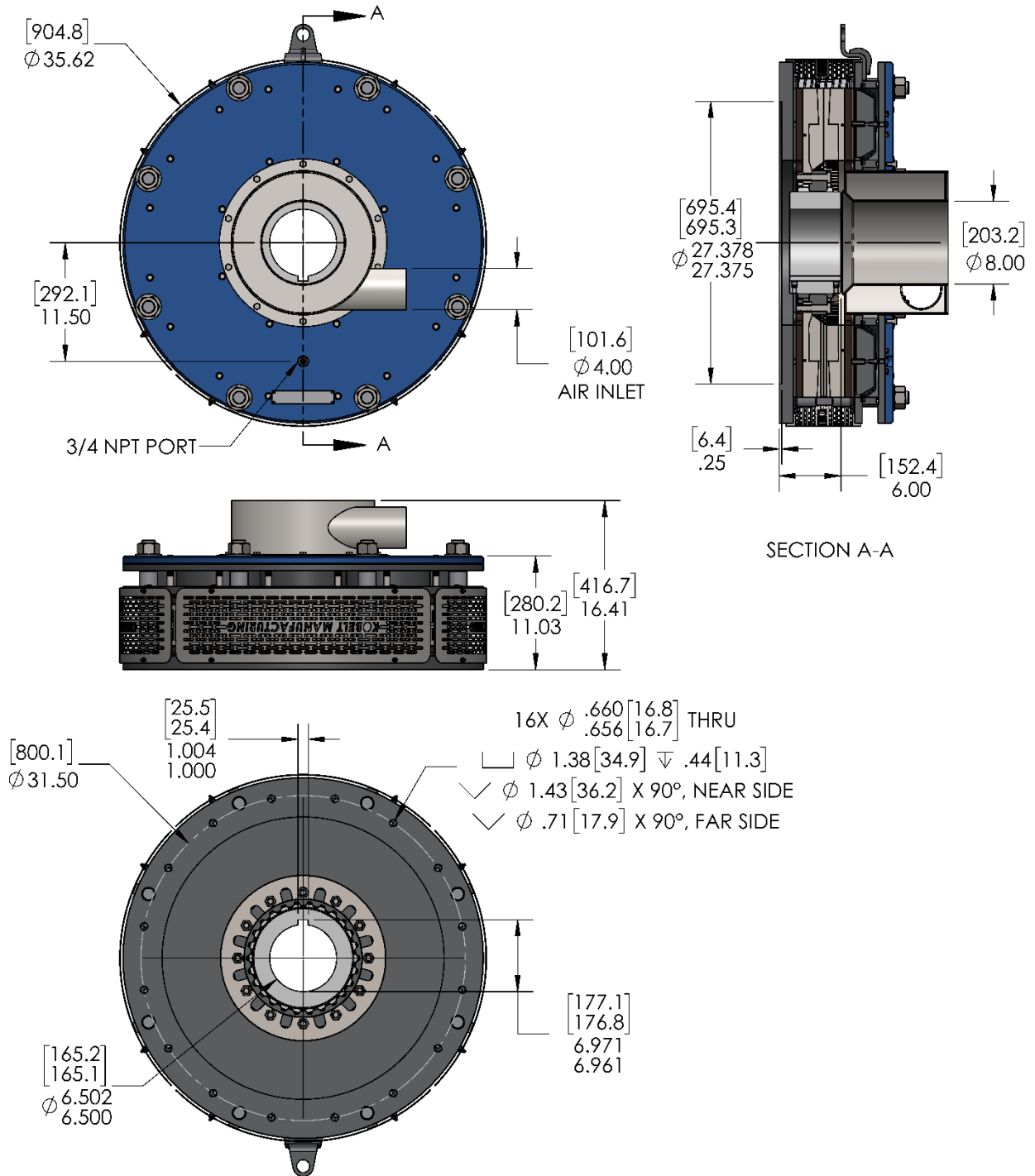

8 APPENDIX B: PARTS LIST DRAWINGS

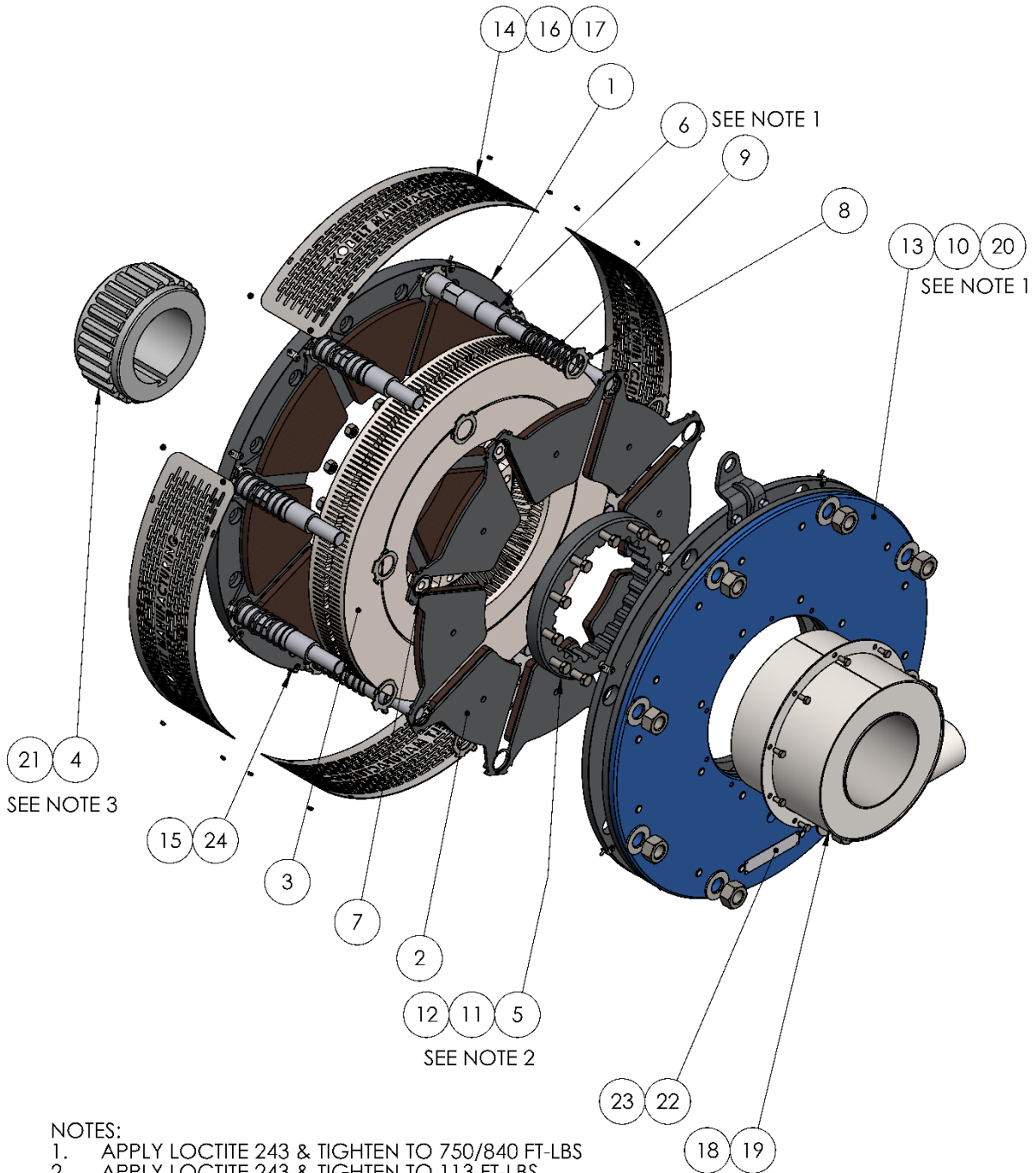

ITEM	QTY	PART NUMBER	DESCRIPTION
1	1	5430-0101	MOUNTING FLANGE
2	16	5430-LS	BRAKE PAD; HIGH COF / 30IN BRAKE
3	1	4-07-30-05	VENTILATED DISC- 4X7X30; DRILLED & BORED
4	1	5430-0103	HUB; 26T SPLINE X 6.5 KEYED BORE
5	1	5430-0020	ADAPTER RING - SPLINED;
6	8	5430-0023	REACTION PIN; 30 IN BRAKE
7	8	1029-1175	RETAINING RING, EXTERNAL, 1-3/4
8	16	5430-0013	PAD RETAINER
9	8	1201-0282	SPRING - COMPRESSION; 2.13OD X .16 WIRE X 6.0 LG
10	8	1022-0125	HEX NUT, 1-1/4-7 UNC, 18-8
11	12	1001-1648	SCREW, HX HD CAP, 5/8 UNC X 3, BUMAX 88
12	12	1022-0116	HEX NUT - REGULAR; 5/8-11 UNC GR 18-8
13	1	5430-1000	ACTUATOR ASSEMBLY; 30IN BRAKE
14	4	5430-0114	GUARD; 5430
15	8	1001-0804	CAP SCREW - HX HD; #10 UNC X 1/4 LG / 18-8
16	16	1023-0108	WASHER, FLAT, #10, 7/16 OD, 18-8 SS
17	16	1022-0108	NUT, HEX, #10-24, 18-8 SS
18	10	1001-1212	SCREW, HX HD, 3/8-16 UNC X 3/4, 18-8
19	1	5430-0115	AIR DUCT; 30 IN BRAKE
20	8	1041-60125	FLAT WASHER; 1-1/4 SAE / ZP
21	2	1016-1410	SET SCREW - CP PT; 1/2 UNC X 0.63 LG / 18-8
22	1	2850-PL	TAG 3/4 X 1-3/4 .04THK ALUMINUM
23	4	1032-0304	SCREW, U-DRIVE, #4 X 3/16, SS
24	8	5430-0016	GUARD BRACKET

5430-1000

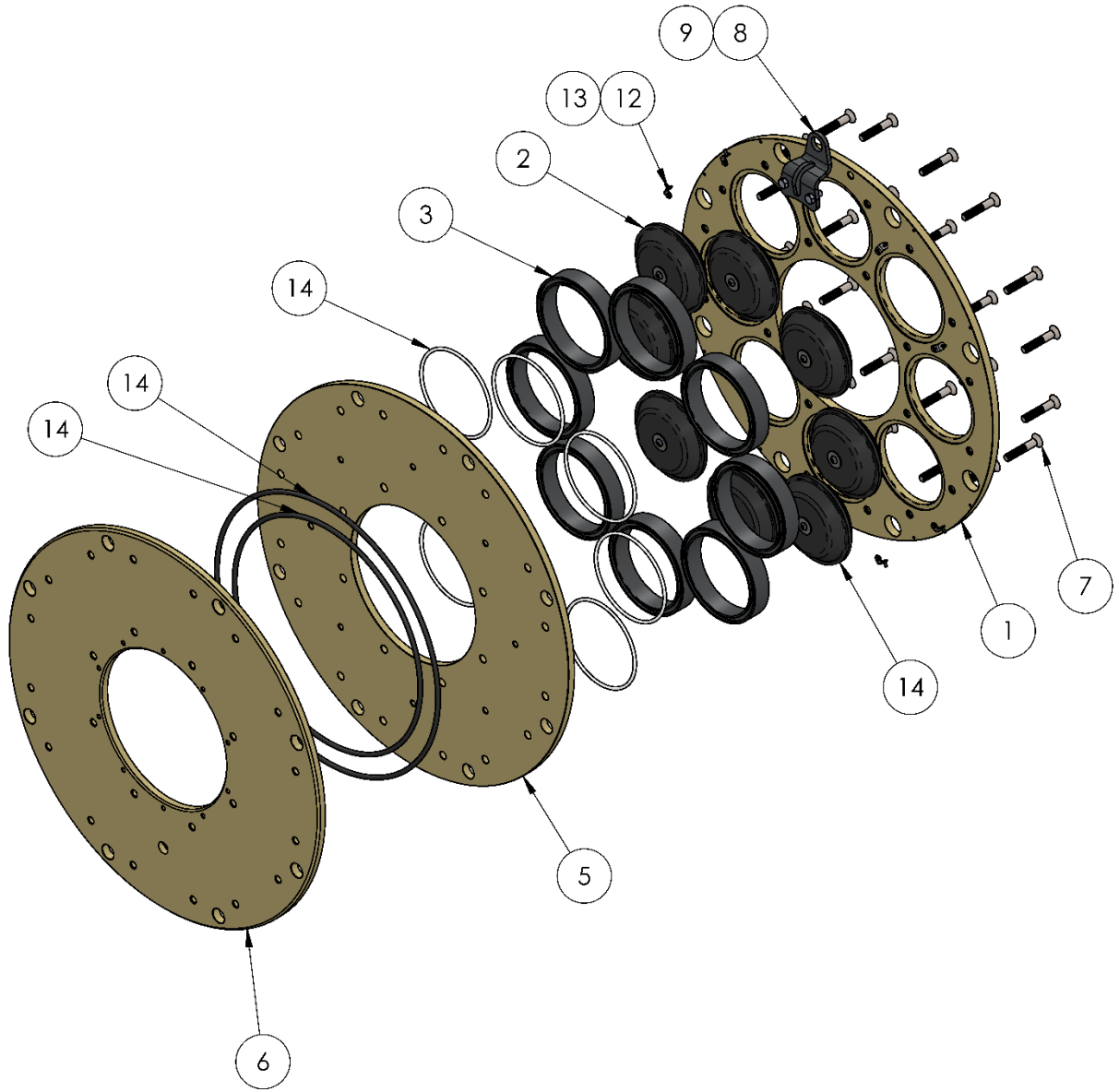

ITEM	QTY.	PART NUMBER	DESCRIPTION
1	1	5430-0104	DIAPHRAGM MAGAZINE, 30IN BRAKE
2	8	5430-0012	PISTON ASSEMBLY; SIZE 30 / INSULATED
3	8	5430-0011	CYLINDER - 30IN BRAKE
4	8	1101-0443	O-RING, 7-3/4IN X 1/4IN, NBR70
5	1	5430-0006	ACTUATOR COVER; 30IN BRAKE
6	1	5430-0002	COVER, 30IN BRAKE
7	24	1015-1656-B	CAP SCREW - FLT HD SKT; 5/8 UNC X 3-1/2 LG / F835 BO
8	1	5430-0018	LIFTING BRACKET; 30IN BRAKE
9	2	1001-1416	HEX HD CAPSCREW, 1/2-13 X 1
10	6	1101-3375	ORING CORD; 3/8 DIA / NBR70
11	6	1101-3375	ORING CORD; 3/8 DIA / NBR70
12	8	5430-0016	GUARD BRACKET
13	8	1001-0804	CAP SCREW - HX HD; #10 UNC X 1/4 LG / 18-8
14	1	5430-RK	REPAIR KIT; 30IN BRAKE