

# ***KOBELT***

## **6503 Electronic Engine Interface**

*Owner's Operation, Installation &  
Maintenance Manual*



June 2025

Kobel Manufacturing Co. Ltd.



# TABLE OF CONTENTS

---

<b>1</b>	<b>Introduction .....</b>	<b>5</b>
1.1	Contact .....	5
1.2	Safety .....	5
1.2.1	Safety Alerts .....	5
1.2.2	Notice to Installer .....	6
1.2.3	Product Hazards .....	6
<b>2</b>	<b>Product Description .....</b>	<b>7</b>
2.1	Technical Data .....	8
<b>3</b>	<b>Installation .....</b>	<b>9</b>
3.1	Receipt .....	9
3.2	Mechanical .....	9
3.2.1	Synchronizer Pickups .....	10
3.3	Electrical .....	11
3.3.1	Power Connection .....	13
3.3.2	Communication Bus Connection .....	13
3.3.3	Electronic Throttle Output Connection .....	14
3.3.4	Electric Clutch Relay Connection .....	15
3.3.5	Tachometer Connection .....	16
3.3.6	Shaft Brake/ Neutral Safety Relay .....	16
<b>4</b>	<b>Commissioning .....</b>	<b>18</b>
4.1	System Configuration .....	18
4.1.1	DIP Switch Settings .....	19
4.1.2	Jumper Settings .....	20
4.1.3	Electronic Throttle Output Adjustment .....	21
4.2	Functional Test .....	22
4.2.1	System Timing Adjustment .....	23
<b>5</b>	<b>Operation .....</b>	<b>25</b>
5.1.1	Throttle and Clutch Control .....	25
5.1.2	Shaft Brake/Neutral Relay Connection .....	25
5.1.3	Synchronizer Function .....	25
5.1.4	Crash Stop Operation .....	25
<b>6</b>	<b>Maintenance .....</b>	<b>27</b>
6.1	Preventative Maintenance .....	27
<b>7</b>	<b>Troubleshooting .....</b>	<b>28</b>
<b>8</b>	<b>Warranty .....</b>	<b>30</b>
<b>9</b>	<b>Revision History .....</b>	<b>31</b>

---

**10    Appendix A: Installation Dimensions..... 32**

**11    Appendix B: Parts List ..... 33**

# 1 INTRODUCTION

## 1.1 CONTACT

**Kobelt Manufacturing Co. Ltd.**  
8238 129th Street  
Surrey, British Columbia  
Canada, V3W 0A6

Sales Tel: +1-604-572-3935  
Fax: +1-604-590-8313  
Email: [sales@kobelt.com](mailto:sales@kobelt.com)  
Website: [www.kobelt.com](http://www.kobelt.com)



This document is intended to clearly present comprehensive product data and provide technical information to assist the end user in design applications. Kobelt reserves the right, without notice, to change the design, or construction, of any products and to discontinue or limit distribution of any products. Kobelt also reserves the right to change, or update, without notice, any technical information contained within this document.

Kobelt recommends that customers visit our website to check for updates to this Manual. Once a product has been selected for use, it should be tested by the user to ensure proper function in all possible applications. For further instructions, please contact our distributors or visit our website.

## 1.2 SAFETY

### 1.2.1 Safety Alerts

Throughout this manual, the following symbols, and their accompanying explanation, are used to alert the user to special instructions concerning a service or operation that may be hazardous if performed incorrectly or carelessly. The associated risk levels are stated below.

 <b>DANGER</b>	This symbol indicates an imminently hazardous situation which, if not avoided, will result in death or serious injury.
 <b>WARNING</b>	This symbol indicates a potentially hazardous situation which, if not avoided, could result in death or serious injury.
 <b>CAUTION</b>	This symbol indicates a hazardous situation, which if not avoided, could result in minor or moderate injury.
<b>NOTICE</b>	This symbol informs the reader of events not related to personal injury but which there is a risk of damage to property or equipment.
<b>SAFETY INSTRUCTIONS</b>	This symbol informs the reader of safety-related instructions or procedures.

### 1.2.2 Notice to Installer

Disregarding the following safety measures can result in an accident-causing severe injury to personnel and damage to material assets.

- Only use the product as directed in this manual.
- Never put the product into service if there is evidence of visible damage.
- Never put the product into service before fully completing installation and commissioning.
- Do not carry out any modifications to the product.
- Only use authentic Kobelt spare parts.
- Observe all local regulations, directives and laws during the installation of this product.
- All installation, commissioning, and maintenance work must only be conducted by qualified personnel. (For the purpose of this manual, qualified personnel are persons who are familiar with the assembly, installation, commissioning, and operation of the product and who have the qualifications necessary for their occupation.)
- Observe all specifications in this manual. If these guidelines are not followed and damage occurs, the warranty will be voided.

### 1.2.3 Product Hazards

 <b>WARNING</b>	<b>Disconnect Power:</b> Turn off power at distribution panel before beginning installation to protect installer from electrical hazards.
--	---

 <b>CAUTION</b>	<b>Voltage and Current Compatibility:</b> Confirm that the power source is compatible with the maximum voltage and current ratings of this product variant. Failure to do so could result in damage or fire.
--	--

---

## 2 PRODUCT DESCRIPTION

---

The 6503 Electronic Engine Control Interface provides electronic throttle control signals and clutch solenoid control signals. It is a component of the Mighty Mariner system.

The 6503 Electronic Control Interface Unit contains a microprocessor and performs the following functions:

- Monitoring input information from the control heads and associated switch panels
- Monitoring clutch and throttle positions. Monitors shaft speed input pulses.
- Controls the electronic throttle and electric clutch based on Control Head lever movement
- Provides feedback to the control stations through panel lights and sonalerts.
- Provides shaft speed synchronization when requested.

The purpose of the 6503 Electronic Engine Interface is to command the electronic throttle signal and operate the clutch solenoid via dry contacts based on the Control Head lever positions. All system adjustments can be made through adjustable trim pots and DIP switches. All connections to the 6503 Electronic Engine Interface are hard wired into pluggable connectors on the board.

The 6503 Electronic Engine Interface is capable of three types of electronic throttle output:

- 4-20mA
- 0-5VDC
- PWM (Pulse Width Modulation).

These outputs change proportionately with the station control head lever positioning.

The Synchronizer System is adjustable to designate either the Port or the Starboard engine as the Main Engine.

The 6503 Electronic Engine Interface is housed in a heavy-duty bronze enclosure designed to prevent dust and moisture ingress.

## 2.1 TECHNICAL DATA

Table 1: 6503 Technical Data

<b>MODEL</b>	<b>6503</b>
<b>KOBELT PART #</b>	6503
<b>SYSTEM COMPATIBILITY</b>	Mighty Mariner
<b>POWER REQUIREMENT</b>	24 VDC (18...29 VDC) <sup>1</sup> MAX 300 mA
<b>OUTPUTS</b>	ANALOG: 40-20mA / 0-5 VDC / PWM RELAY: 1x NEUTRAL SAFETY 2x CLUTCH
<b>SWITCHING CAPACITY</b>	NEUTRAL SAFETY: MAX 1 A CLUTCH: MAX 4 A (PER OUTPUT)
<b>TERMINALS</b>	SCREW TYPE 3.5MM PITCH 26AWG TO 16AWG
<b>EMC</b>	EMMISSIONS: PER IEC60945 IMMUNITY: AS PER IEC60945
<b>FINISH TYPE</b>	Bronze
<b>OPERATING TEMPERATURE</b>	-13°F ... 131°F [-25°C ... 55°C] 95% HUMIDITY
<b>VIBRATION RESISTANCE</b>	0.7 G

Notes:

1. Control systems using the 6652 control head must maintain a minimum of 22 VDC to avoid triggering a low voltage alarm.

## 3 INSTALLATION

### 3.1 RECEIPT

Upon receipt of the device ensure that the model number and serial number, as indicated on the enclosure, are noted in table on page 2 of this manual. This model number will determine what spare parts are applicable.

### 3.2 MECHANICAL

The location of the 6503 Electronic Engine Interface must meet the following conditions:

- The location must be accessible for service
- The unit must not be exposed to excessive vibrations.
  - Do not mount on the engine or the clutch
- This unit must not be mounted in areas exposed to washdown.
- The unit must not be exposed to excessive heat.

The electronic engine interface enclosure must be mounted on a flat surface. The enclosure is equipped with (4) four clearance holes for #10 [M4]. Tighten the fasteners to 23 in-lbs [4 Nm] with an anaerobic thread locker such as Loctite 243.

#### NOTICE

The 6503 Control Unit must be mounted so that the enclosure is completely isolated from the vessel's structure.

Use the supplied insulating bushings to prevent any metal-to-metal contact between the 6503 assembly and the vessel.

#### WARNING

##### **Vibration Damage:**

Do Not Mount the 6503 on the Engine or the Clutch. Damage from vibration may occur.

#### WARNING

This enclosure is not waterproof. Do not immerse or wash down.

#### WARNING

Do not mount this unit near sources of heat.



Do not mount this unit near high power devices such as motors, heaters, radio transmitters or other sources of electro-magnet interference.

### 3.2.1 Synchronizer Pickups

The Synchronizer Pickups are mounted near the propeller shafts. These are proximity sensors that send one pulse per shaft revolution to the 6503 Electronic Engine Interface. A metal target must be mounted to the shaft to trigger the Synchronizer Pickup on each rotation. The proximity switches must be mounted within the sensing range of the shaft mounted target.

Table 2: Synchronizer Target Sizing Guide

SYNCHRONIZER TARGET SIZING	
<b>SUGGESTED DIMENSIONS</b>	2-3" X 1" X 1/8" [50-75mm X 25mm X 3.175mm]
<b>RECOMMENDED MATERIAL</b>	Mild Steel
<b>MAXIMUM SENSING GAP (MILD STEEL)</b>	0.050" [1.3mm]
<b>MAXIMUM SENSING GAP (STAINLESS STEEL)</b>	0.035" [0.9mm]

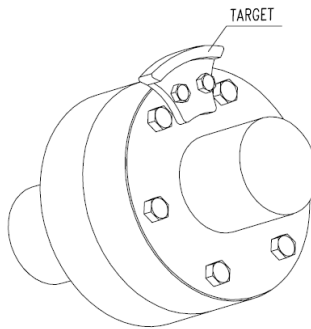

Figure 1: Example Synchronizer Target Location

Proper sizing and alignment of the pickup and target is required for operation. The target material should be mild steel, however stainless steel can be used with a reduced sensing gap.

- The size of the target can be increased if necessary. Some installations may require larger targets for proper operation.
- The target outer radius must be concentric with the shaft.
- The target should be a minimum of 12mm or ½" away from any other solid metal object to avoid interference.
- The target must also be securely installed so that it does not become dislodged.
- The Synchronizer Pickup must be mounted on a vibration-free bracket that allows for adjustment of the sensing gap.

Review the instructions that come with the sensor for additional installation information. If the Synchronizer Pickup and target are mounted correctly, a red LED on the Synchronizer Pickup should flash when the target is detected ([see section 3.3.5](#)).

## NOTICE

### Additional Instructions:

Please review the instructions that come with the sensor for additional installation information.

## NOTICE

### Additional Instructions:

If the target is not concentric with the shaft, a double pickup might occur.

## WARNING

### No Interference between Sensor and Target:

If the proximity switch comes in contact with the rotating target, it will be destroyed.

## 3.3 ELECTRICAL

The 6503 Electronic Engine Interface features eight cable glands for making electrical connections. Use cables with an outer diameter between 0.28 inch [7 mm] and 0.47 inch [12 mm] and refer to the section below for the recommended wire gauge. Use ferrules on the cable ends for all wire connections.

Plug connectors are supplied on the board inside the enclosure. Use these connectors for making the connections to the control board.

## NOTICE

**Shielding and Grounding Connections:** All shield and ground connections for the Kobelt Electronic Control System must be terminated at the 6503 Control Unit only. The 6503 is internally grounded and must not be connected to the vessel's grounding system.

**WARNING**

**Disconnect Power:** Turn off power at distribution panel before beginning installation, or removing the cover, to protect installer from electrical hazards.

Electrical installation of the 6503 Electronic Engine Interface should proceed as follows:

1. Remove the cover of the die-cast bronze enclosure.
2. Connect electrical cables and power wires, as per details in this section of the manual and according to relevant drawings.
3. Visually inspect all wiring is correctly installed.
4. Replace the cover of the die-cast bronze enclosure.

**WARNING**

**Do Not Coil Cables:** Cut the cables if they are too long, do not coil them. Coiled cables can cause fires.

**NOTICE**

**Check All Connections:** Improper wiring connections may result in damage to the 6503 Electronic Engine Interface Unit.

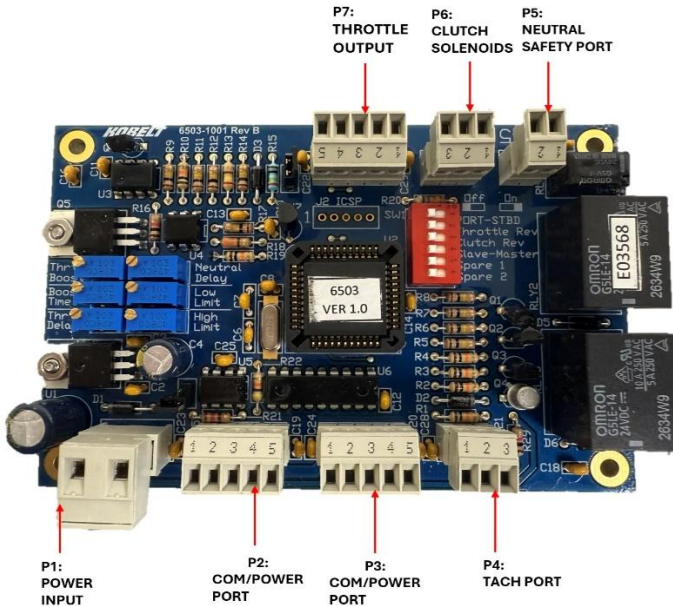

*Figure 2: Internal 6503 Enclosure Connections*

Connectors P1, P2, and P7 are mandatory and required for operation of the 6503 Electronic Engine Interface. Connectors P3, P4, P5, and P6 are optional depending on system configuration.

### 3.3.1 Power Connection

*Table 3: Power Input Connector*

<b>P1 POWER INPUT</b>			
<b>Pin #</b>	<b>Pin Name</b>	<b>Pin Type</b>	<b>Function</b>
<b>1</b>	VDC+	Power	Main Power Input (from power switch)
<b>2</b>	COM	Power	Main Ground

The recommended power cable is single-pair, 12 AWG, and it is recommended to connect two power sources with one serving as the primary and the other as a secondary backup.

### 3.3.2 Communication Bus Connection

Terminate the communication bus to connector P2. The circuit board has an internal resistor that can be switched in (see section 4.1.2) therefore, no external resistor is required at P2. If the 6503 Engine Interface is not the last node on the control bus, the outgoing cable will be terminated at connector P3. Use two-pair, 18 AWG shielded cable for the communication cable.

*Table 4: Primary COM/POWER Port Connector*

<b>P2 COM/POWER PORT</b>			
<b>Pin #</b>	<b>Pin Name</b>	<b>Pin Type</b>	<b>Function</b>
<b>1</b>	VDC+	Power	Bus Supply
<b>2</b>	COM	Power	Bus Common
<b>3</b>	DATA+	Data	Bus Data (differential pair)
<b>4</b>	DATA-	Data	
<b>5</b>	Shield	Shield	Cable Shield Connection

*Table 5: Secondary COM/POWER Port Connector*

<b>P3 COM/POWER PORT</b>			
<b>Pin #</b>	<b>Pin Name</b>	<b>Pin Type</b>	<b>Function</b>
<b>1</b>	VDC+	Power	Bus Supply
<b>2</b>	COM	Power	Bus Common
<b>3</b>	DATA+	Data	Bus Data (differential pair)
<b>4</b>	DATA-	Data	
<b>5</b>	Shield	Shield	Cable Shield Connection

### 3.3.3 Electronic Throttle Output Connection

Terminate the throttle control cable at connector P7. Use two conductor (1 pair) shielded cable with a minimum cross section of 22 AWG. The shield must be connected at the 6503 board.

Wiring arrangements for different throttle outputs are shown below:

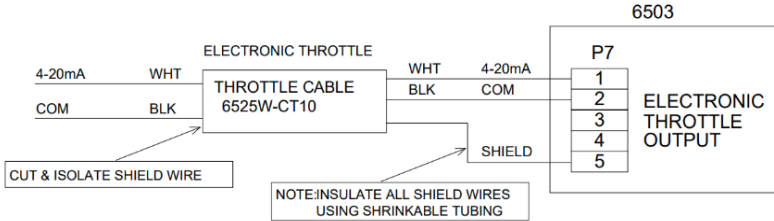

Figure 3: 4-20mA Throttle Wiring Diagram

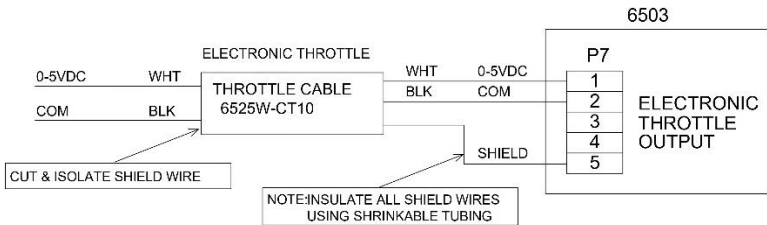

Figure 4: 0-5VDC Electronic Throttle Wiring Diagram

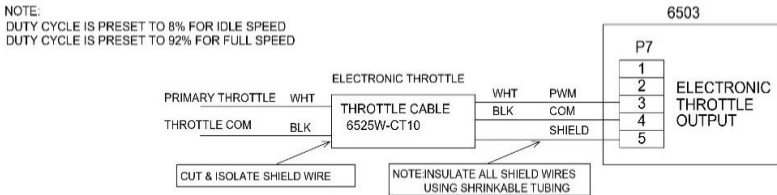

Figure 5: PWM Electronic Throttle Wiring Diagram

Table 6: Electronic Throttle Connector

P7	THROTTLE OUTPUT
----	-----------------

Pin #	Pin Name	Pin Type	Function
1	0-5VDC, or 4-20mA	Output	Electronic Throttle Analog Output
2	COM	Power	Electronic Throttle Analog Common
3	PWM	Output	Electronic Throttle PWM Output
4	COM	Power	Electronic Throttle PWM Common
5	Shield	Shield	Electronic Throttle Shield

## NOTICE

The shield must not be connected to the engine side.

### 3.3.4 Electric Clutch Relay Connection

Terminate the clutch control cable at connector P6. Use 3 conductor, 18 AWG cable. Pin 1 is for forward, Pin 3 is for reverse, and Pin 2 is solenoid common.

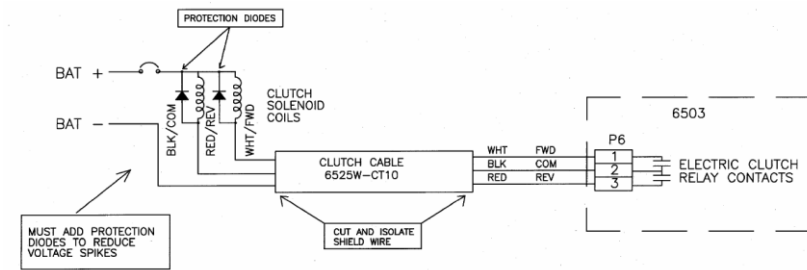

Figure 6: 6503 Clutch Wiring Diagram

Table 7: Electric Clutch Solenoid Connector

P6 CLUTCH SOLENOIDS			
Pin #	Pin Name	Pin Type	Function
1	FWD	Output	Clutch Forward Solenoid Output
2	COM	Power	Clutch Solenoid Common
3	REV	Output	Clutch Reverse Solenoid Output

## NOTICE

Clutch solenoids could be wired to switch positive instead of switching to ground, if so reverse protection diodes.

**WARNING**

Protection diodes must be installed to reduce voltage spikes.  
Protection diode P/N 1N4005 or 1N4007 are recommended.

### 3.3.5 Tachometer Connection

The tachometer proximity switch connects directly to the 6503 P4 connector using a 3-conductor, 18AWG cable as shown in Figure 7. The Kobelt 6001-3708 proximity sensor is recommended.

Table 8: Synch Port Connector

P4 TACH PORT			
Pin #	Pin Name	Pin Type	Function
1	VDC+	Power	Synchronizer Sensor Power
2	PULSE OUTPUT	switch	Synchronizer Signal
3	COM	Common	Synchronizer Sensor Common

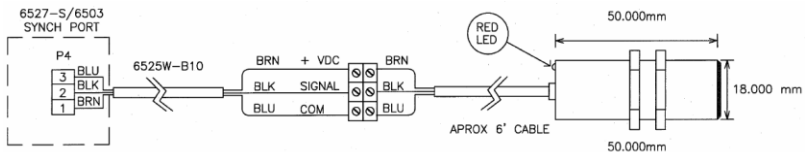

Figure 7: Synchronizer Pickup Wiring Diagram

### 3.3.6 Shaft Brake/ Neutral Safety Relay

Connector P5 is used for controlling shaft brakes or as an engine start interlock. Use 2 conductor #18 AWG cable for this purpose. The output is a dry contact so polarity coordination is not required.

Table 9: Shaft Brake/ Neutral Safety Port Connector

P5 SHAFT BRAKE/ NEUTRAL SAFETY PORT			
Pin #	Pin Name	Pin Type	Function
1	N/O	Output	Relay Contact, N/O
2	COM	Power	Relay Contact, Common

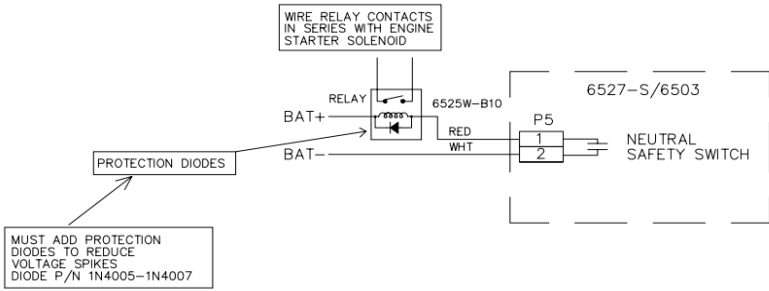

Figure 8: Neutral Safety Switch Wiring Diagram

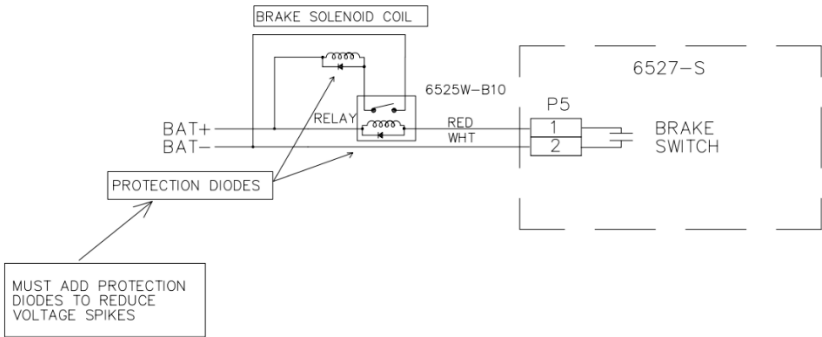

Figure 9: Brake Switch Wiring Diagram

**WARNING** When using output to control a shaft brake, the relay switching limit must be observed.

**WARNING** **Neutral Safety Switch Bypass:** A bypass for the neutral safety switch must be provided to permit starting the engine if the control system has failed.

**NOTICE** **Relay Current:** Relay contacts must be able to handle starter solenoid current. Relay is customer supplied.  
**Protection Diodes:** Protection diodes must be used on all external relays to avoid damaging the system.

## 4 COMMISSIONING

### 4.1 SYSTEM CONFIGURATION

- Turn OFF the power to the 6503 prior to adjusting the trim pots or DIP switches.
- Use a **non-conductive** flathead screwdriver to adjust the trim pots or DIP switches.
- Make the required adjustments as noted in the relevant sections below.
- Turn ON power.
- Test the system to verify desired response.
- Repeat as necessary, until the unit functions as desired.
- Replace the enclosure cover.



#### **WARNING**

**Turn off the engine:** Engine must not be running during system calibration.



#### **CAUTION**

The following adjustments must only be performed by qualified personnel, and only while the vessel is at dock.



#### **CAUTION**

To adjust these trim pots and DIP switches, the enclosure may need to be open while the unit is powered, creating an electrical short/shock hazard.



#### **CAUTION**

To reduce the potential for electrical shock and to avoid damaging the electronics, use a **non-conductive** screwdriver, or other equivalent tool, to adjust the trim pots and DIP switches.



#### **CAUTION**

Exercise caution when reaching in with the screwdriver. Do not let it touch any components other than the trim pots and DIP switches.

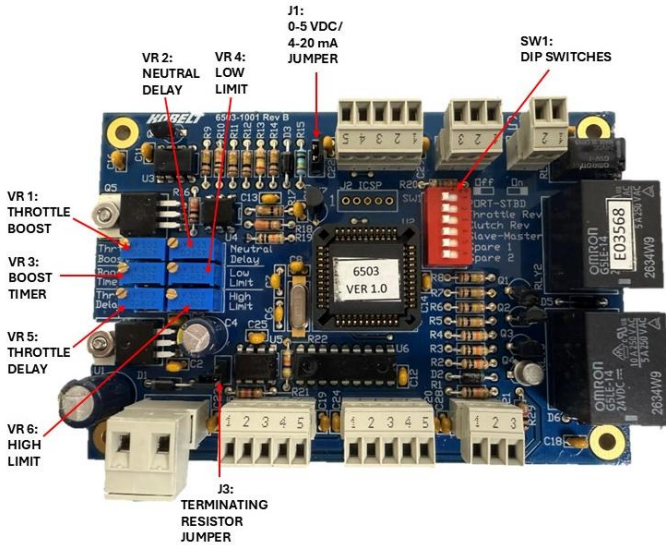

Figure 10: Adjustment Connections

## NOTICE

Ensure that no oil or other contaminants enter the enclosure while the cover is removed.

### 4.1.1 DIP Switch Settings

System behavior is adjusted via the DIP switch settings. Switches 5 and 6 are not used and must be set to the OFF position.

The standard configuration produces a throttle signal which is minimum value for idle speed and maximum value for full speed. For example, 4mA is equal to idle speed and 20 mA is equal to full speed. If the vessel's engine(s) require a reverse acting electronic signal, the output can be electrically reversed by setting DIP switch #2 to the ON position.

Ensure that switch 1 is set correctly for each engine. Ensure that switch 4 is set to "main" on one engine controller and "auxiliary" on the other.

## NOTICE

One card must be set to PORT and the other to STBD Do not set both to the same switch position (SW 1).

**NOTICE**

One card must be set to MAIN and the other to AUXILIARY. Do not set both to the same switch position (SW 4).

Note for single engine configuration: SW 1 must be set to OFF position (PORT unit).

Follow the table below to configure the system for a specific vessel.

Table 10: DIP Switch Configuration

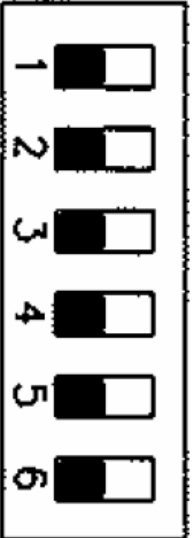
		SW 1 Function			
		OFF POSITION	ON POSITION	ELECTRONIC ENGINE INTERFACE	FUNCTION
	PORT UNIT	STBD UNIT	N/A	TOGGLES PORT AND STBD	
	NORMAL	REVERSE	THROTTLE SIGNAL	CHANGE THROTTLE TRAVEL DIRECTION	
	NORMAL	REVERSE	CLUTCH SIGNAL	CHANGE CLUTCH TRAVEL DIRECTION	
	AUXILIARY	MAIN	N/A	TOGGLES MAIN AND AUXILIARY SYNCHRONIZER	
	NOT USED	NOT USED	NOT USED	NOT USED	
	NOT USED	NOT USED	NOT USED	NOT USED	
	NOT USED	NOT USED	NOT USED	NOT USED	

**NOTICE**

Reversing the engine signal might cause damage to the clutch. Extreme caution is required.

#### 4.1.2 Jumper Settings

Ensure that the terminating resistor jumper J3 is present and connecting both pins at the last Electronic Engine Interface Unit (see Figure 10). It will internally connect a 120 OHM terminating resistor to the CAN bus at connector P2.

The throttle output can be configured to provide a 4-20mA, 0-5VDC, or a PWM signal for electronic governor systems. The correct output type for the vessel's engines must be selected during the installation. To produce a 0-5VDC throttle output, jumper J1 must be installed in position. For 4-20 mA throttle output, this jumper must be removed. The 6503 is already preset to produce PWM signal (see section 3.3.2: [Electronic Throttle Output Connection](#)).

Table 11: Jumper Output Selection

J1 & J3 Jumper Function		
JUMPER	INSTALLED	REMOVED
J1	P7-1 & P7-2 WILL PRODUCE 0-5VDC	P7-1 & P7-2 WILL PRODUCE 4-20mA
J3	120 OHM TERMINATING RESISTOR INSTALLED	NO TERMINATING RESISTOR

## NOTICE

The last component on the bus must have a 120-ohm resistor or network communication will be lost.

### 4.1.3 Electronic Throttle Output Adjustment

The signal limits of the throttle control as well as the magnitude of the throttle boost must be set prior to use. The gain adjustments referenced in the table below are made by adjusting the trim pots identified in Figure 10.

Table 12: Electronic Throttle Output Adjustment

ELECTRONIC THROTTLE OUTPUT ADJUSTMENT					
POT	NAME	FUNCTION	RANGE	DIRECTION	RATE
VR 1	THROTTLE BOOST	Sets level of high idle when shifting into gear	0%-25% THROTTLE	CW = increase CCW = decrease	1.25 TURN/1% THROTTLE
VR 4	LOW LIMIT ADJUST	Sets idle speed	0% - 40% THROTTLE SIGNAL		0.75 TURN/1% THROTTLE
VR 6	HIGH LIMIT ADJUST	Sets maximum engine speed	60% - 100% THROTTLE SIGNAL		0.75 TURN/1% THROTTLE

**4.1.3.1 4-20mA Calibration**

- 1) Connect the positive lead of the ammeter to terminal 1 of P7.
- 2) Connect the common lead of ammeter to terminal 2 of P7.
- 3) Set the control lever to idle and adjust VR4 (low limit) trimpot until 4 mA is obtained.
- 4) Set the control lever to full speed and adjust VR6 (high limit) trimpot until 20 mA is obtained.



**Turn off the engine:** Engine must not be running during signal calibration.

**4.1.3.2 0-5VDC Calibration**

- 1) Connect the positive lead of the voltmeter to terminal 1 of P7.
- 2) Connect the common lead of voltmeter to terminal 2 of P7.
- 3) Set the control lever to idle and adjust VR4 (low limit) trimpot until 0 VDC is obtained.
- 4) Set the control lever to full speed and adjust VR6 (high limit) trimpot until 5 VDC is obtained.

**4.1.3.3 PWM Calibration**

With a multimeter, measure the duty cycle at terminals 3 & 4 of P7.

- 1a) Alternatively, disconnect the cable from the engine, use a battery and a 1K ohm resistor to measure the duty cycle.
- 1b) Use a voltmeter that can read duty cycle to measure the PWM signal.
- 2) Set the control lever to idle and adjust VR4 (low limit) trimpot until 8% duty is obtained.
- 3) Set the control lever to idle and adjust VR4 (low limit) trimpot until 92% duty is obtained.

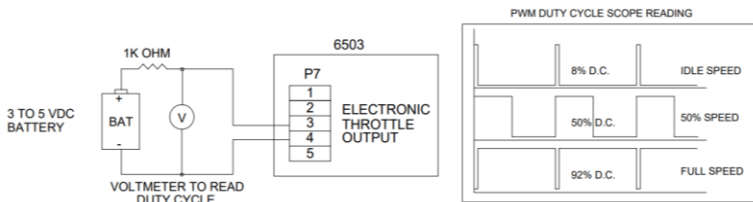

Figure 11: PWM Calibration

## 4.2 FUNCTIONAL TEST

Once the system calibration is complete and with the engine shut down, connect the clutch and the throttle cables to the 6503 electronic interface. With a multimeter, move the control

levers and verify whether the throttle signal and the clutch relay contacts are responding to the lever commands. Confirm full range of engine speed and adjust the appropriate trim pots until designed signal is obtained.

Once the system has been thoroughly tested, and all the functions are operational, engines can be started and tested at the idle RPM.



## CAUTION

Ensure that the cover is installed and secured before powering on the 6503.

If installed, monitor the synchronizer proximity switch. An LED should flash if synchro pickup and target are installed properly.

Once everything has been tested and adjusted, a sea trial can be initiated.

### 4.2.1 System Timing Adjustment

The time delays are used to assist the vessel performance in a crash stop maneuver. The timing adjustments referenced in the table below are made by adjusting the trim pots identified in Figure 10. These settings must be made and tested during sea trials.

Table 13: System Timing

SYSTEM TIMING					
POT	NAME	FUNCTION	RANGE	DIRECTION	RATE
VR 2	NEUTRAL DELAY	Provides a time delay before engaging the opposite direction clutch.	0-24 SECONDS		1.25 TURN/SEC
VR 5	THROTTLE DELAY	Delays throttle response after engaging the clutch in the opposite direction.	0-24 SECONDS	CW = increase CCW = decrease	1.25 TURN/SEC
VR 3	THROTTLE BOOST TIME	Sets duration of <b>Throttle Boost</b> after shifting into gear when changing directions.	0-5 SECONDS		6 TURN/SEC

## NOTICE

Throttle delay must be set to minimum for throttle boost time to be effective.

**NOTICE**

Set throttle delay for 1 second minimum and neutral delay for 1 second minimum.

**NOTICE****Twin Engine Configuration:**

Neutral delay and throttle delay must be set identical for both cards.

**CAUTION**

The Functional Test should be carried out while the vessel is still at dock and before it is taken out to sea.

---

## 5 OPERATION

---

### 5.1.1 Throttle and Clutch Control

The clutch is automatically engaged prior to reaching the first detent position of the control handle. Once past the detent, throttle speed ramps up proportionally to the handle position, providing smooth and intuitive power delivery.

### 5.1.2 Shaft Brake/Neutral Relay Connection

The Shaft Brake/Neutral Relay Output is a normally open contact that close when the control head handles are in the neutral position. This relay can be used either to control a shaft brake or to act as an engine start interlock. As the forward or reverse clutch is activated, the relay opens, and the brake is deactivated.

The relay is interlocked to clutch neutral position, the engine can only be started when the system is powered, and the Control Head levers are in the neutral position.

### 5.1.3 Synchronizer Function

To enable engine synchronization, press the synchro switch located on the control head. When synchronization is active, the system allows one control lever to operate both clutches and synchronized engines simultaneously, ensuring coordinated performance.

For synchronization to engage or disengage properly, the main and auxiliary control levers must be positioned within a 10 percent range of each other. This ensures smooth transition and prevents potential imbalance between engine controls.

### 5.1.4 Crash Stop Operation

The diagrams below illustrate the influence of the three adjustable time delays during a crash stop sequence.

The Neutral Delay Timer (VR2) delays clutch engagement into the opposite direction until the timer has run out. After the Neutral Delay Timer has run out the Throttle Delay Timer (VR5) starts. This timer delays the throttle response to allow time for the clutch to fully engage.

Throttle Boost (VR1) is used to increase the engine speed for a period set by the Throttle Boost Time (VR3) to avoid stalling the engine during direction reversal. The Throttle Boost Timer starts concurrently with the Throttle Delay Timer and may not seem effective if the Throttle Delay Time is set too long. Set the Throttle Delay to a minimum required to engage the clutch.

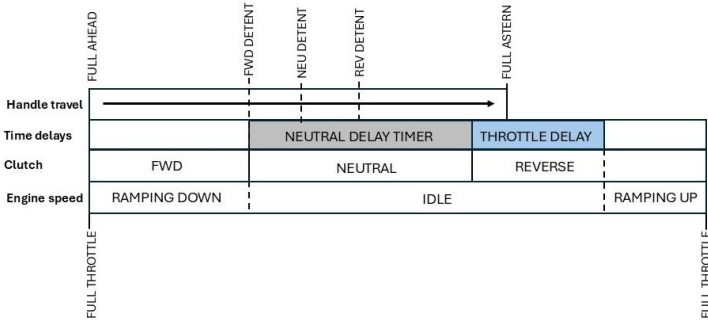

Figure 12: Throttle Delay Timing Diagram

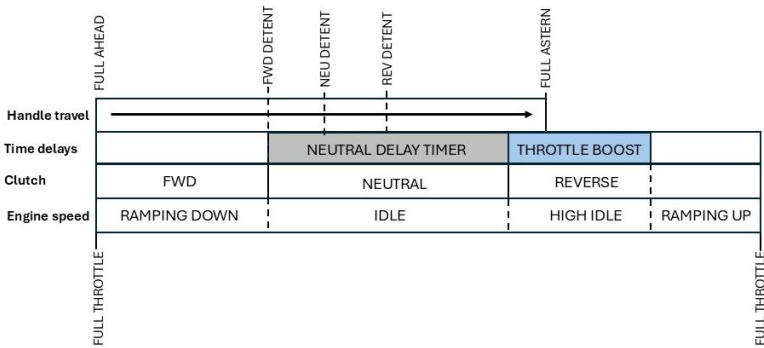

Figure 13: Throttle Boost Timing Diagram

<b>NOTICE</b>	Throttle delay must be set to minimum for throttle boost time to be effective.
---------------	--

## 6 MAINTENANCE

---

### 6.1 PREVENTATIVE MAINTENANCE

- Yearly
  - Ensure the cover is tight.
  - Ensure the enclosure interior is dry.

When purchasing spare parts refer to Appendix B: Parts List at the back of this manual for Kobelt component Part Numbers.

#### **NOTICE**

It is recommended that any required service work on a Kobelt unit be performed by a factory authorized service representative. Please contact the nearest Kobelt authorized distributor for assistance.

## 7 TROUBLESHOOTING

Kobel propulsion control systems are programmed to annunciate certain faults at the control heads. If you encounter an alarm with your product, please refer to the trouble-shooting suggestions below before contacting Kobelt for assistance. If the steps below do not resolve your issue, please reach out either Kobelt directly or our Dealers in your area.

Table 15: Alarm codes

Symptom	Possible Causes	Corrective Action
<b>Continuous sonalert beep</b>	CPU hung up	Reset system by turning the power off
<b>One single beep</b> The control head will become disabled	The 6505S Control Head DIP switches are incorrectly set	Ensure that every device on the network has a unique address.
All control heads will become disabled	The 6503 interface card DIP switches are incorrectly set	
<b>Two consecutive beeps</b>	System temperature over 60C	Turn the system off and provide better cooling.
<b>Four or seven consecutive beeps</b> Control head and station lock will become disabled.  Control can be transferred to other stations if equipped	Communication fault	Inspect network wiring for loose connections. Ensure terminating resistor in place.
<b>Six consecutive beeps</b>  Control head and station lock will become disabled.  Control can be transferred to other stations if equipped	Control head potentiometer is damaged  One or more of the control head pot wires are broken	Check the potentiometer and replace if necessary

Table 16: Troubleshooting

Symptom	Possible Causes	Corrective Action
<b>The system is dead</b>	The power is off	Turn the power on
	The polarity is reversed on the DC power input	Reverse the connections
<b>The system is not synchronizing</b>	The synchronizer is not set properly	Adjust the distance between the sensor and the target until the LED starts flashing
	There is a problem with the synchronizer wiring	Check the wiring
<b>Ground fault indicated</b>	6503 enclosure is grounded to vessel	Check isolation; ensure nylon bushings installed
<b>Throttle boost not working</b>	Throttle delay is not set correctly	Set throttle delay to minimum

---

## 8 WARRANTY

---

Kobelt Manufacturing Co. Ltd. ("Kobelt") warrants the Products and Parts manufactured by Kobelt to be free from defects in workmanship or material and that said products are designed mechanically and functionally to perform to specifications.

This warranty is effective providing:

- The equipment is used within the intended operating conditions and in accordance with Kobelt recommendations
- The equipment is installed according to equipment diagrams, specifications and recommendations which Kobelt has provided

This warranty becomes invalid if the factory supplied serial number has been removed or altered on the product. This warranty does not cover cosmetic damage or damage caused by an act of God, accident, misuse, abuse, negligence or modification of any part of the product. This warranty does not cover damage due to improper operation or maintenance, connection to inappropriate equipment or attempted repair by anyone other than an authorized Kobelt representative.

Upon identification of a potential issue or defect with a Kobelt Product or Part, the Warranty Applicant ("Applicant") must immediately contact Kobelt and describe the issue in writing, by letter, fax, email or other electronic conveyance. Kobelt will then assess the cause of the defect and determine warranty applicability and appropriate remediation.

If any part is found to be defective, Kobelt will replace said part FOB the Kobelt factory provided that any such defective part is returned by the Buyer with freight and applicable forwarding charges prepaid by the Buyer. Kobelt's sole obligation to the Applicant will be to repair or replace the defective part with same or similar product, to a maximum value of the list price of the product or part. The Kobelt warranty does not cover labour charges, travel or any other associated expenses.

All Products and Parts manufactured by Kobelt, are subject to a warranty against manufacturer's defects in materials or workmanship for a period of two (2) years from the date of purchase.

Kobelt will be responsible for all Products or Parts sold by Kobelt but manufactured by 3<sup>rd</sup> party manufacturing companies. However, these products and parts are subject to applicable 3<sup>rd</sup> party warranties and may not be the same as the Kobelt warranty.

## 9 REVISION HISTORY

Table 16: Table of revision changes

Document Revision	Release Date	CO	Author	Revision Summary
A	2025-05-14	n/a	MW	<ul style="list-style-type: none"> <li>Initial release</li> </ul>
B	2025-06-16	01262	MW	<ul style="list-style-type: none"> <li>added low voltage alarm note (page 8)</li> </ul>
C	2025-11-27	01363	MW	<ul style="list-style-type: none"> <li>added isolation note (page 9)</li> <li>added grounding note (page 11)</li> <li>added ground fault entry (page 29)</li> <li>Shoulder washers added to the Part List (page 33)</li> </ul>

# 10 APPENDIX A: INSTALLATION DIMENSIONS

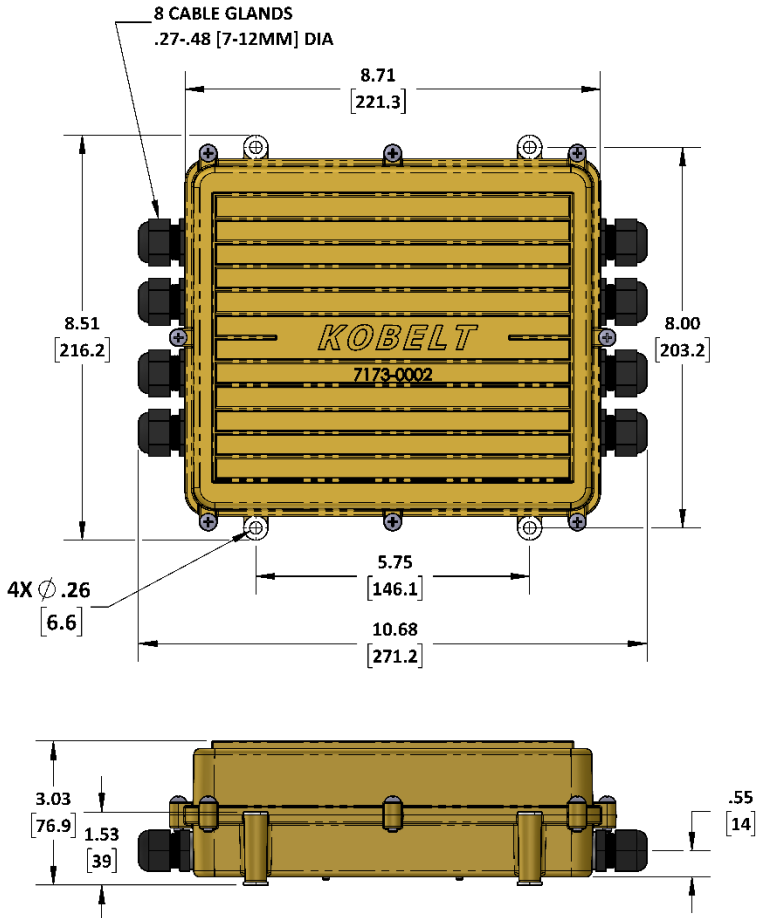
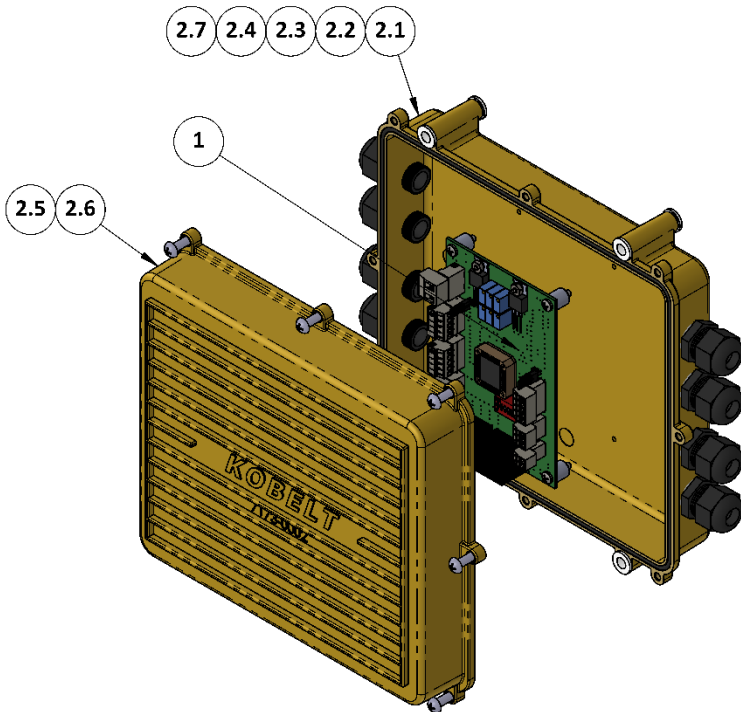

Figure 14: 6503 Installation Dimensions

# 11 APPENDIX B: PARTS LIST



ITEM	QTY.	PART NUMBER	DESCRIPTION
1	1	6503-3001	BOARD ASSEMBLY; MM ELECTRONIC ENGINE INTERFACE
2	1	6503-BOX	ENCLOSURE ASSEMBLY
2.1	1	7173-0003-8-E	ENCLOSURE, 8 HOLE
2.2	8	6001-0248-W-M16	WASHER, SEALING, M16, POLYETHYLENE
2.3	8	6001-0248	CABLE GLAND; M16 X 1.5, .197-.394 CABLE, PA6, BLACK
2.4	1	1101-0177	O-RING, 9-1/2 ID X 3/32 IN, NBR 70
2.5	8	1010-0810	SCREW, RND HD, PHL DRIVE, 10-24 X 5/8, 18-8
2.6	1	7173-0002	ENCLOSURE, 7IN X 8.25IN, TOP, BRONZE
2.7	8	6009-7210	SHOULDER WASHER; 1/4 SCREW X .513 OD, NYLON

Figure 15: 6503 Parts Diagram

# ***KOBELT***

**Kobelt Manufacturing Co. Ltd.**

8238 129th Street  
Surrey, British Columbia,  
Canada, V3W 0A6

Sales Tel: +1-604-572-3935

Fax: +1-604-590-8313

Email: [sales@kobelt.com](mailto:sales@kobelt.com)

Website: [www.kobelt.com](http://www.kobelt.com)

Made in Canada / Printed in Canada