

KOBELT

6509 Electronic Control Head

*Owner's Operation, Installation &
Maintenance Manual*



Table of Contents

1	Introduction	4
1.1	Contact	4
1.2	Safety	4
1.2.1	Safety Alerts	4
1.2.2	Notice to Installer.....	4
1.2.3	Product Hazards	5
2	Product Description	6
2.1	Overview.....	6
2.2	Technical Data	7
2.3	Model Configuration Key.....	8
3	Installation	9
3.1	Receipt.....	9
3.2	Mechanical	9
3.3	Electrical	9
3.4	DIP Switch Settings	11
3.4.1	6525 System	11
3.4.2	Mighty Mariner System.....	11
3.5	Functional Test	12
4	Operation	12
5	Maintenance	13
5.1	Preventative Maintenance	13
5.2	Calibration	14
5.3	Potentiometer Connection.....	14
5.4	Lubrication.....	15
5.5	Recommended Spare Parts and Kits	15
6	Troubleshooting	16
7	Warranty	17
8	Revisions History	18
9	Appendix A: Installation Dimensions	19
10	Appendix B: Parts List	20
11	Appendix C: Installation Cut-out Template.....	22

1 INTRODUCTION

1.1 CONTACT

Kobelt Manufacturing Co. Ltd.
8238 129th Street
Surrey, British Columbia
Canada, V3W 0A6

Sales Tel: +1-604-572-3935
Fax: +1-604-590-8313
Email: sales@kobelt.com
Website: www.kobelt.com



This document is intended to clearly present comprehensive product data and provide technical information to assist the end user in design applications. Kobelt reserves the right, without notice, to change the design, or construction, of any products and to discontinue or limit distribution of any products. Kobelt also reserves the right to change, or update, without notice, any technical information contained within this document.

Kobelt recommends that customers visit our website to check for updates to this Manual. Once a product has been selected for use, it should be tested by the user to ensure proper function in all possible applications. For further instructions, please contact our distributors or visit our website.

1.2 SAFETY

1.2.1 Safety Alerts

Throughout this manual, the following symbols, and their accompanying explanation, are used to alert the user to special instructions concerning a service or operation that may be hazardous if performed incorrectly or carelessly. The associated risk levels are stated below.

 DANGER	This symbol indicates an imminently hazardous situation which, if not avoided, will result in death or serious injury.
 WARNING	This symbol indicates a potentially hazardous situation which, if not avoided, could result in death or serious injury.
 CAUTION	This symbol indicates a hazardous situation, which if not avoided, could result in minor or moderate injury.
NOTICE	This symbol informs the reader of events not related to personal injury but which there is a risk of damage to property or equipment.
SAFETY INSTRUCTIONS	This symbol informs the reader of safety-related instructions or procedures.

1.2.2 Notice to Installer

Disregarding the following safety measures can result in an accident, causing severe injury to personnel and damage to material assets.

- Only use the product as directed in this manual.
- Never put the product into service if there is evidence of visible damage.
- Never put the product into service before fully completing installation and commissioning.
- Do not carry out any modifications to the product.

- Only use authentic Kobelt spare parts.
- Observe all local regulations, directives and laws during the installation of this product.
- All installation, commissioning, and maintenance work must only be conducted by qualified personnel. (For the purpose of this manual, qualified personnel are persons who are familiar with the assembly, installation, commissioning, and operation of the product and who have the qualifications necessary for their occupation.)
- Observe all specifications in this manual. If these guidelines are not followed and damage occurs, the warranty will be voided.

1.2.3 Product Hazards

 WARNING	Equipment Starts Automatically: Equipment may activate suddenly while servicing this product, causing bodily harm. Ensure that all power sources are locked out prior to performing work.
--	---

 WARNING	Pinch Points: The 6509 control head contains pinch points, which can cause bodily harm. Ensure that hands and fingers remain clear of the pinch points when performing work.
--	--

2 PRODUCT DESCRIPTION

2.1 OVERVIEW

The Kobelt 6509 electronic control head provides a 10-bit digital output, communicated via CANbus or RS485, that is proportional to the handle position. This output is used by Kobelt's Mighty Mariner or 6525 controller to control engine throttle, clutch engagement or propellor pitch. The handle also has three detent positions; one at neutral plus another two to correspond with clutch activation points in both ahead and astern. The unit is equipped with a keypad to control Station Select, Station Lock, Throttle Override and Engine Synchronizer functions.

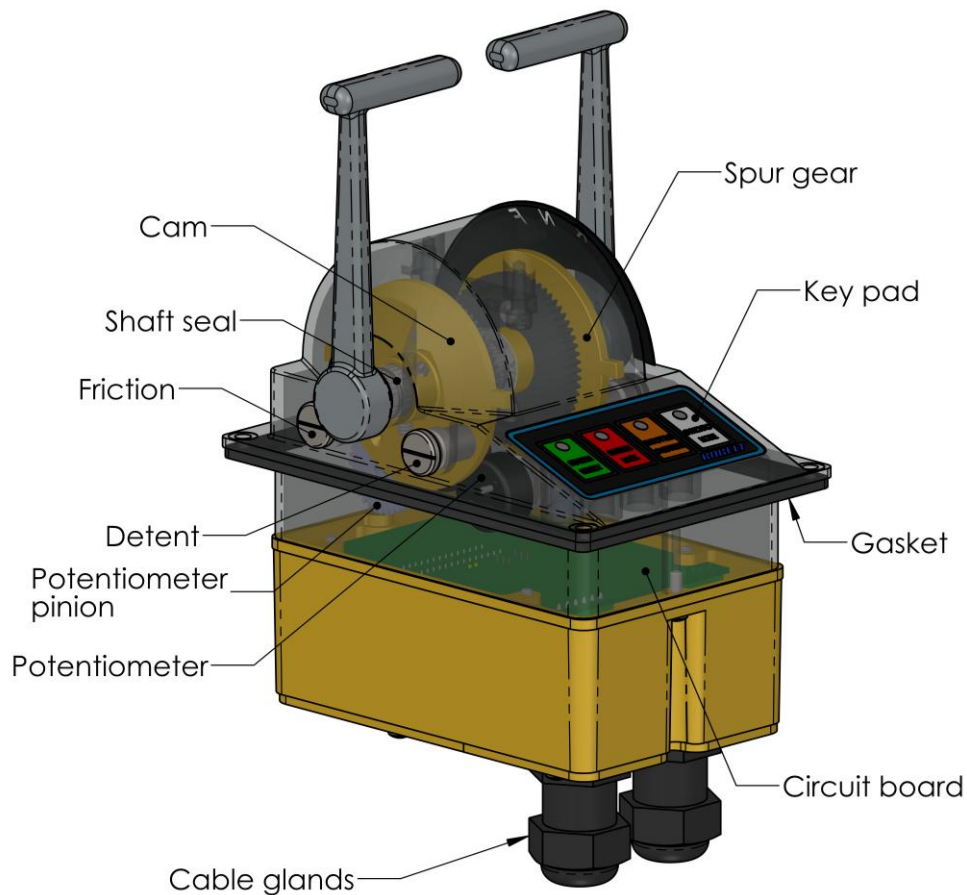

Figure 1: Control head overview

2.2 TECHNICAL DATA

Handle Travel:

- Neutral: 0° detented
- Clutch in: +/- 20° detented
- Full travel: +/- 78°

Output: 10 bit

Connection¹: CANbus (Mighty Mariner)
RS485 (6525 system)

Terminals: 22-16 AWG, screw clamp

Voltage: 7-28VDC

Maximum Power: 3.6W

Finish: Polyester powder coat
Textured black

Weight: 6.2 lbs [2.8 kg]

Notes:

1. 132 ft [40m] maximum

2.3 MODEL CONFIGURATION KEY

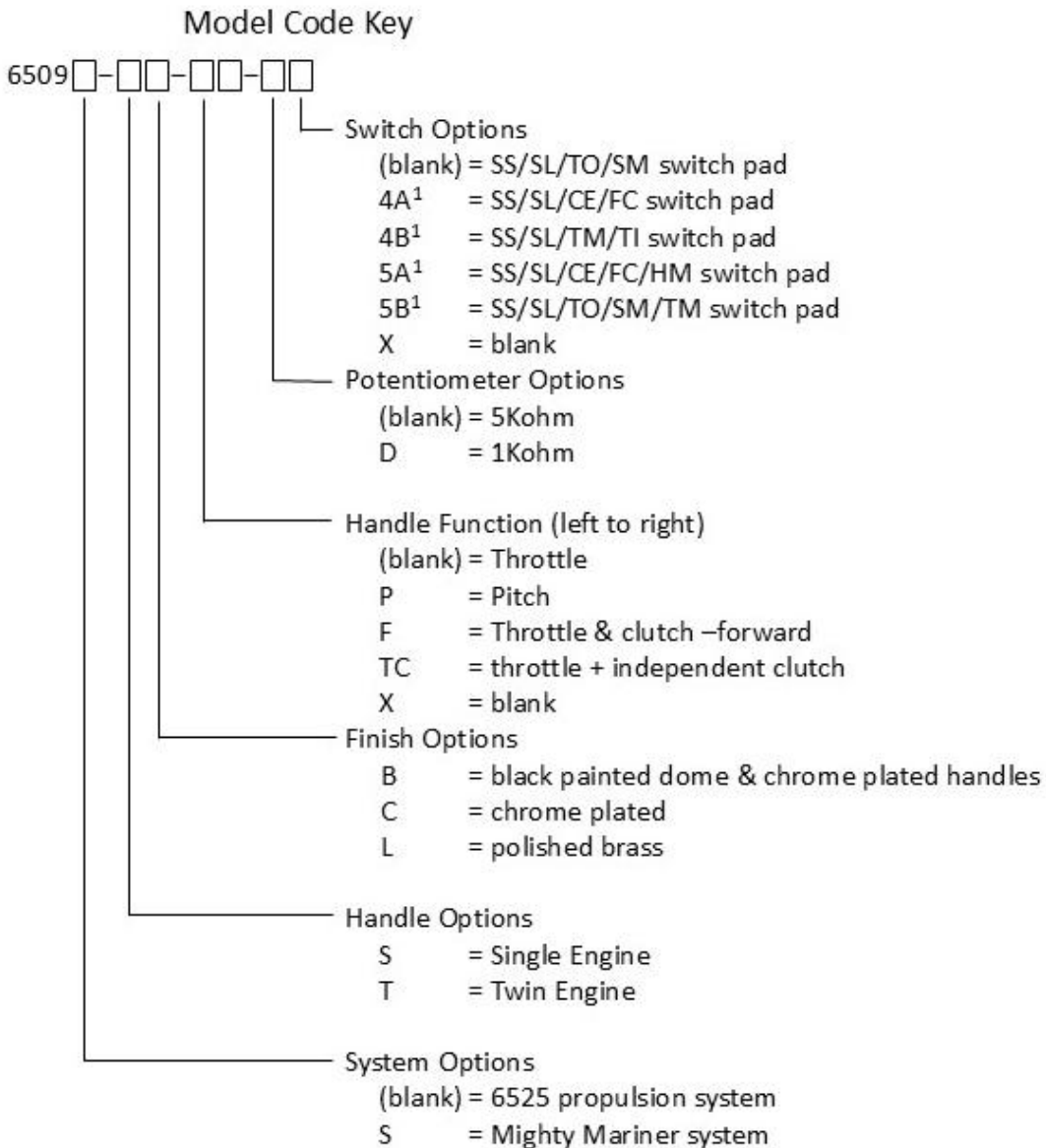

Notes:

1. Only available with 6525 system
2. SS = station select
 SL = station lock
 TO = throttle override
 SM = engine synchronizer mode
 CE = clutch engage
 TM = trolling mode
 TI = trolling idle
 FC = feather control
 HM = harbour mode

3 INSTALLATION

3.1 RECEIPT

Kobel offers the 6509 control head in numerous configurations (reference [section 2.3](#)). Upon receipt of the device ensure that the model number and serial number are noted on the table in page 2 of this manual. This model number will determine what spare parts are applicable.

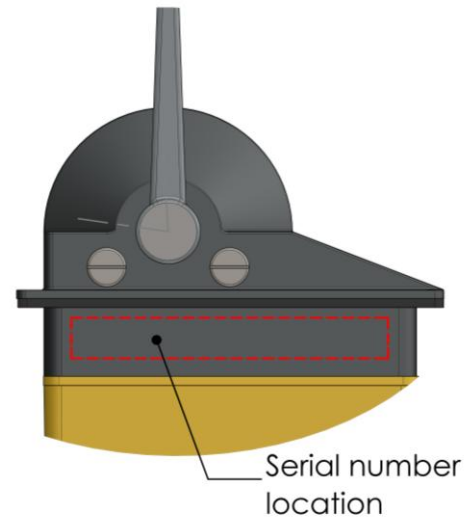

Figure 2: Serial number location

3.2 MECHANICAL

The control head must be mounted on a flat surface with a maximum roughness of $ra = 125$ micro-inches [$500 \mu\text{m}$]. The mounting surface must have the following minimum thickness to prevent excessive flexing;

Steel consoles:	0.19 inches [4.8 mm]
Aluminum consoles:	0.27 inches [6.8 mm]

Choose a location that has sufficient room for the handle to swing to both extreme positions. Use the template at the back of this manual to make the correct cut-out on the mounting surface.

The control head is equipped with (4) four clearance holes for #10 [M4]. Use #10 or M4 socket cap sealing screws or bonded sealing washers to prevent water ingress past the mounting screws. Tighten the fasteners to 23 in-lbs [4 Nm] with an anaerobic thread locker such as Loctite 243.

NOTICE

Failure to follow the installation requirements of this section will not adequately compress the gasket and therefore compromise the ingress protection.

3.3 ELECTRICAL

The 6509 control head is equipped with two cable glands with which to make the electrical connections. Use 0.20 inch [5 mm] to 0.47 inch [12 mm] OD cable with 18 AWG conductors for external connections to the engine controller. The cable must be twisted pair and shielded to protect signal integrity. Use ferrules on the cable ends for all wire connections.

Plug connectors are supplied on the board inside of the control head. They can be accessed by removing the bottom cover. Use these connectors for making the connections to the control head. No power connections are required as the unit receives power through the network from the controller. Up to eight control heads can be connected in a 'daisy chain' fashion to the appropriate connector for making the CPU connections. Refer to the figures below as the circuit board and connector numbers are different depending on whether it is a Mighty Mariner or a 6525 system. The last control head must have a 120 ohm resistor installed between the data terminals (pins 3 & 4).

NOTICE

The last control head must have a 120 ohm resistor between terminals 3 & 4 or network communication will be lost.

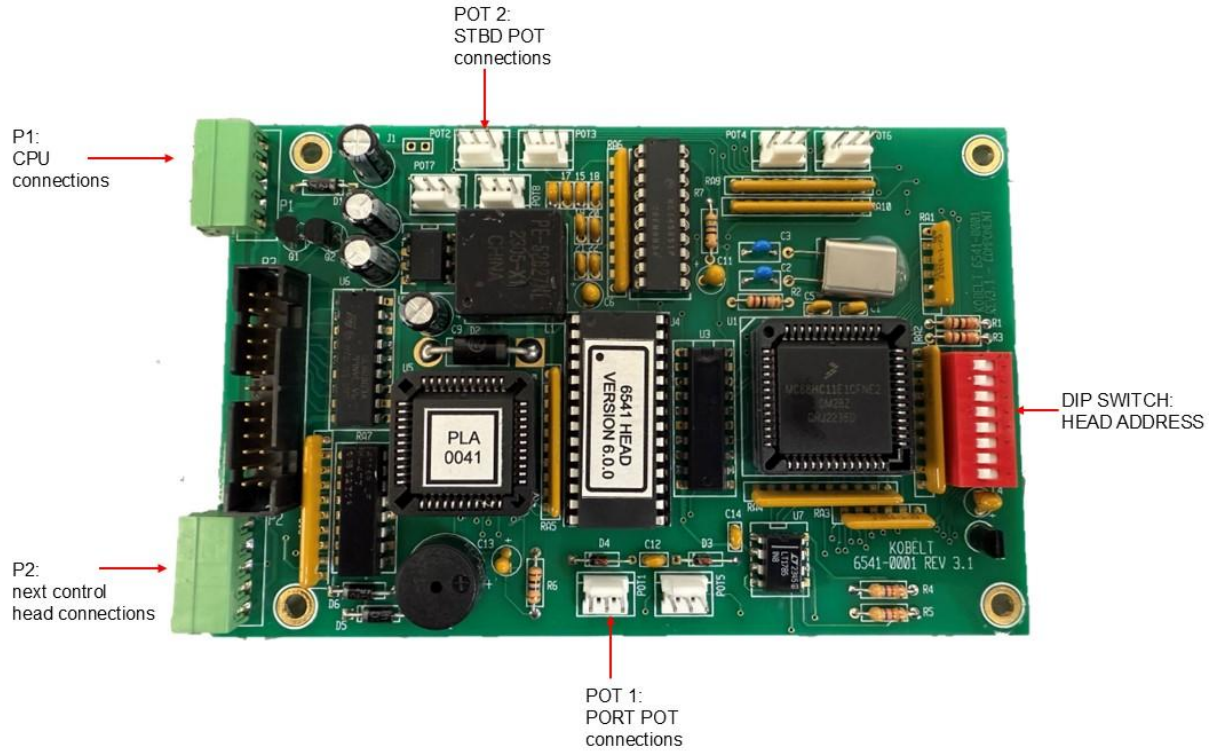

Figure 3: 6509 Wire Connections – 6525 System

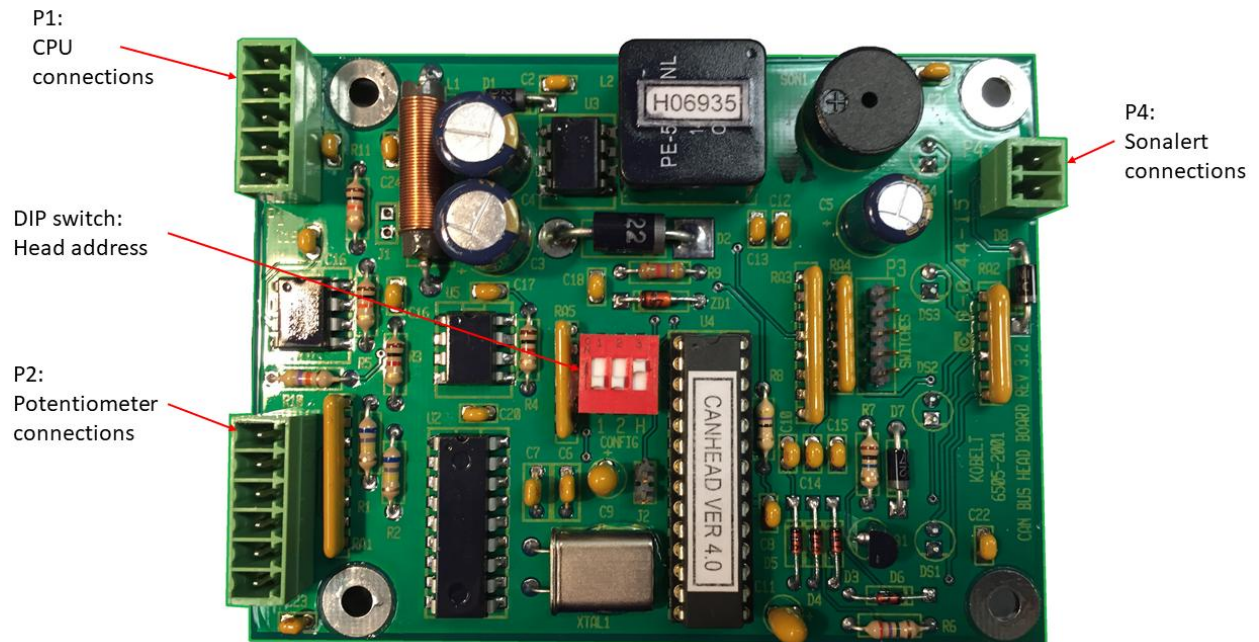

Figure 4: 6509S Wire Connections - Mighty Mariner System

Table 1: CPU Connector termination

Pin #	Signal	Conductor	Function
1	+ VDC	WHT 2	Bus supply
2	COM	BLK 2	Bus common
3	DATA+	WHT 1	Bus data -H
4	DATA-	BLK 1	Bus data - L
5	SHIELD	SHIELD	Shield

When connecting the Sonalert buzzer to connector P4, ensure that the positive wire is connected to terminal 1.

Before completing the wiring, remember to leave enough extra cable length to permit removal of the control head without disconnecting the wiring.

3.4 DIP SWITCH SETTINGS

3.4.1 6525 System

The network address of each control head is assigned via a DIP switch on the circuit board. Each switch corresponds to a specific station address from 1 to 8. To assign a station address, set only the switch corresponding to that address to ON; all other switches must remain OFF.

Table 2: Control Head Address

Station Address	DIP Switches							
	SW1	SW2	SW3	SW4	SW5	SW6	SW7	SW8
1	ON	OFF	OFF	OFF	OFF	OFF	OFF	OFF
2	OFF	ON	OFF	OFF	OFF	OFF	OFF	OFF
3	OFF	OFF	ON	OFF	OFF	OFF	OFF	OFF
4	OFF	OFF	OFF	ON	OFF	OFF	OFF	OFF
5	OFF	OFF	OFF	OFF	ON	OFF	OFF	OFF
6	OFF	OFF	OFF	OFF	OFF	ON	OFF	OFF
7	OFF	OFF	OFF	OFF	OFF	OFF	ON	OFF
8	OFF	OFF	OFF	OFF	OFF	OFF	OFF	ON

Set each control head to a different address number. Ensure that station 1 is assigned to the bridge or main station as this is the unit that will automatically get control after power up.

3.4.2 Mighty Mariner System

The network address of each control head is assigned via the first two switches of a three pole DIP switch on the circuit board. Set the switches as shown in the table below:

Table 3: Control Head Address

Station Address	DIP Switches		
	SW1	SW2	SW3
1	OFF	OFF	(2)
2	ON	OFF	(2)
3	OFF	ON	(2)
4	ON	ON	(2)

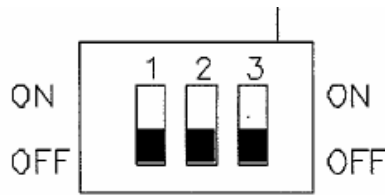

Figure 5: Station ID DIP Switches

Set each control head to a different address number. Ensure that station 1 is assigned to the bridge or main station as this is the unit that will automatically get control after power up.

Note 2) Switch #3 is used to configure the system for single or twin engines. Set switch SW3 to the OFF position for single engine applications.

NOTICE

Set each control head to a different address number. Addressing conflicts will generate a system fault.

3.5 FUNCTIONAL TEST

Upon power up, the main station sonalert will start beeping and the STATION SELECT lamp will blink. If this is not happening, inspect the wiring. After successful power up, press the STATION SELECT switch to assume control from the current station.

Once in control, test that the clutches engage and disengage as expected and that the full range of throttle control is available.

CAUTION

Do not put the equipment into service until the control head has been tested. The Functional Test should be carried out while the equipment is safely secured.

4 OPERATION

The 6509 control head can be equipped with either four or five membrane buttons. Both configurations are compatible with fixed-pitch vessels and controllable pitch propeller vessels, with button functions varying according to the propeller type.

STATION SELECT permits the transfer of engine control to another station. On power-up, station control automatically is assigned to station 1 (main station).

STATION LOCK allows the operator to lock out the other control stations.

THROTTLE OVERRIDE disables the clutch function so that the engine can be operated to full throttle without turning the propellers. This feature is useful for engine warm-up or testing.

To return to the normal operating mode, return the handle positions back to neutral (TDC) and press the button again.

SYNCHRONIZER Pressing this button enables the propeller speed synchronization feature, which uses external speed sensors to measure the speed and permit the controller to match the engine speeds. The operator only needs to move one or the other throttle handle to control both engine speeds.

When pressing the button, the light will flash until the engine speeds are synchronized. As long as the engine speeds are within the controller dead-band, the light remains solid on. The synchronizer function is not available when the propulsion controls are in trolling mode.

CLUTCH ENGAGE turns on the output to the clutch. The operation is interlocked to handle idle position.

TROLLING MODE enables precise low-speed control of the vessel by reducing the minimum propeller pitch and engine speed range.

TROLLING IDLE sets the engine to operate at a reduced idle speed while in trolling mode, optimizing fuel efficiency and lowering noise.

FEATHER CONTROL drives the actuator output to an extreme position to stow the CPP propeller. The operation is interlocked to the neutral and idle condition.

HARBOUR MODE allows full control over pitch while engine remains at idle speed.

NOTICE

Do not use the propulsion controller's SYNCHRONIZER function if the engine ECU also has a synchronizer function as unpredictable states may occur.

5 MAINTENANCE

5.1 PREVENTATIVE MAINTENANCE

- Quarterly (4 times per year)
 - Lubricate the detent track (reference [section 5.4](#))
 - Ensure that the friction drag is adequate.
- Every 2 years
 - Inspect detent plate. Replace if necessary.
 - Replace shaft seal
- Every 5 years
 - Replace potentiometers

5.2 CALIBRATION

When replacing the potentiometer or if the setting has become disturbed, follow these steps to center the output:

1. Position the handle in the center (neutral) position.
2. Remove the control head bottom cover.
3. Locate the potentiometer in need of centering.
4. Connect a multimeter to the Pot – (white wire) and the Pot Wiper (green wire). Set the meter to read resistance.
5. Loosen the two locking set screws on the pinion gear with a 1/16-inch Allen key.
6. Using a short flat head screwdriver, rotate the potentiometer shaft until the meter reads half of the rated output (2500 ohms for a 5K potentiometer).
 - a. Note: compare the output between the wiper and Vref+ to wiper and Vref-. Adjust the shaft to balance.
7. Tighten the two locking set screws and replace the cover.

Loosen set screws and turn potentiometer shaft to center output

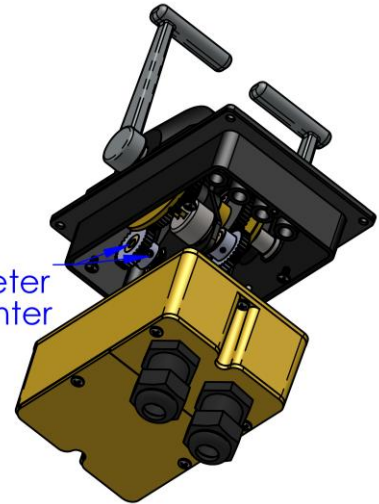

After centering the control head, calibrate the throttle output to the 6525 controller. To perform this function set DIP switch #4 to the OFF position and follow the prompts from the 6525 propulsion controller. After completion, return DIP switch #4 to the ON position.

5.3 POTENTIOMETER CONNECTION

The control head potentiometers are wired to the Potentiometer Connector. When replacing these devices ensure that they are connected as per the table below:

Table 4: Potentiometer Connector Termination²

Pin #	Signal	Pot terminal	Function
1	Vref-	Pot 2, terminal 3	STBD Pot Negative Reference
2	POT2	Pot 2, terminal 2	STBD Pot Wiper Input
3	Vref+	Pot 2, terminal 1	STBD Pot Positive Reference
4	Vref-	Pot 1, terminal 1 ¹	PORT Pot Negative Reference
5	POT1	Pot 1, terminal 2	PORT Pot Wiper Input
6	Vref+	Pot 1, terminal 3 ¹	PORT Pot Positive Reference

1. The potentiometers are wired mirror image to synchronize the outputs.
2. Note: The CPU connector is labeled as follows:
 - a. 6525 system: P1
 - b. Mighty Mariner system: P1

5.4 LUBRICATION

The track the detent runs along on the detent plate must be lubricated to prevent premature wear. Use a grease with MoS₂ additives for best results. The following greases are approved:

Table 5: Approved Lubricants

EP Grease Brand
CHEVRON DELO MOLY 5% EP2
MOBIL XHP-322
SHELL S3 V460

5.5 RECOMMENDED SPARE PARTS AND KITS

The spare parts kept on hand will depend on the severity of the service. The User should monitor the condition of their control head to predict necessary spare parts and ensure they are on hand when needed. As a minimum Kobelt recommends keeping the following parts for each control head in service:

Table 6: Recommended Spare Parts

Part Number	Description	Qty
2545-0012	Detent Plunger	2
2545-0021	Friction Button	2
POT-5	Potentiometer	2
YPB-3232	Pinion Gear	2
6509-0015	SCALE - R-N-F/ RH	1
6509-0016	SCALE - R-N-F / LH	1

When purchasing spare parts refer to [Appendix B](#) at the back of this manual for Kobelt component Part Numbers.

NOTICE	It is recommended that any required service work on a Kobelt unit be performed by a factory authorized service representative. Please contact the nearest Kobelt authorized distributor for assistance.
---------------	---

The table below identifies spare part numbers that vary by configuration; refer to it to ensure the correct parts are selected.

Table 7: Configuration Part Numbers

Configuration Part Numbers		
System Code	Control Board	System Type
(blank)	6505-1001-CBOARD	6525 system
S	6505-2001-CBOARD	Mighty Mariner
Potentiometer Code	Potentiometer	Resistance
(blank)	POT-5	5 kohm
-D	POT-1	1 kohm
Membrane Code	Membrane	Functions
(blank)	6012-0016	SS/SL/TO/SM
-4A	6012-0022	SS/SL/CE/FC
-4B	6012-0010	SS/SL/TM/TI
-5A	6012-0002	SS/SL/CE/FC/HM
-5B	6012-0006	SS/SL/TO/SM/TM

6 TROUBLESHOOTING

Kobel propulsion control systems are programmed to announce certain faults at the control heads. If you encounter an alarm with your product, please refer to the trouble-shooting suggestions below before contacting Kobel for assistance. If the steps below do not resolve your issue, please reach out either Kobel directly or our Dealers in your area.

Table 8: Alarm Codes - Mighty Mariner systems

Alarm Code	Cause	Corrective Action
Continuous	CPU hung up	Reset system by turning the power off
One beep	Station ID conflict - address DIP switches not correctly set	Ensure that every device on the network has a unique address.
Two beeps	System temperature over 60C	Turn the system off and provide better cooling.
Three beeps	Actuator fault – jammed or motor failed	Inspect the push/pull cable. Inspect motor condition.
Four beeps	Communication fault	Inspect network wiring for loose connections. Ensure terminating resistor in place.
Five beeps	Loop fault – actuator potentiometer failure	Test the potentiometer output with a multimeter. Replace if necessary.
Six beeps	Loop fault – control head potentiometer failure	Test the potentiometer output with a multimeter. Replace if necessary.
Seven beeps	Communication fault	Inspect network wiring for loose connections. Ensure terminating resistor in place.

Table 9: Alarm Codes - 6525 systems

Alarm Code	Cause	Corrective Action
Continuous	CPU hung up	Reset system by turning the power off
	Station ID conflict - address DIP switches not correctly set	Ensure that every device on the network has a unique address.
	Communication fault	Inspect network wiring for loose connections. Ensure terminating resistor in place.
One beep	Actuator fault – jammed or motor failed	Inspect the push/pull cable. Inspect motor condition.
Pulsating tone	System temperature over 60C	Turn the system off and provide better cooling.
Three beeps	Loop fault – control head potentiometer failure	Test the potentiometer output with a multimeter. Replace if necessary.

7 WARRANTY

Kobel Manufacturing Co. Ltd. (“Kobel”) warrants the Products and Parts manufactured by Kobel to be free from defects in workmanship or material and that said products are designed mechanically and functionally to perform to specifications.

This warranty is effective providing:

- The equipment is used within the intended operating conditions and in accordance with Kobel recommendations
- The equipment is installed according to equipment diagrams, specifications and recommendations which Kobel has provided

This warranty becomes invalid if the factory supplied serial number has been removed or altered on the product. This warranty does not cover cosmetic damage or damage caused by an act of God, accident, misuse, abuse, negligence or modification of any part of the product. This warranty does not cover damage due to improper operation or maintenance, connection to inappropriate equipment or attempted repair by anyone other than an authorized Kobel representative.

Upon identification of a potential issue or defect with a Kobel Product or Part, the Warranty Applicant (“Applicant”) must immediately contact Kobel and describe the issue in writing, by letter, fax, email or other electronic conveyance. Kobel will then assess the cause of the defect and determine warranty applicability and appropriate remediation.

If any part is found to be defective, Kobel will replace said part FOB the Kobel factory provided that any such defective part is returned by the Buyer with freight and applicable forwarding charges prepaid by the Buyer. Kobel’s sole obligation to the Applicant will be to repair or replace the defective part with same or similar product, to a maximum value of the list price of the product or part. The Kobel warranty does not cover labour charges, travel or any other associated expenses.

All Products and Parts manufactured by Kobel, are subject to a warranty against manufacturer’s defects in materials or workmanship for a period of two (2) years from the date of purchase.

Kobel will be responsible for all Products or Parts sold by Kobel but manufactured by 3rd party manufacturing companies. However, these products and parts are subject to applicable 3rd party warranties and may not be the same as the Kobel warranty.

8 REVISIONS HISTORY

Table 10: Table of revision changes

Document Revision	Release Date	CO	Author	Revision Summary
B	2025-06-16	01262	MW	<ul style="list-style-type: none">• updated voltage and power rating• updated model code key• updated electrical wire connections• updated DIP switch settings• updated operation configurations• updated CPU connector pin locations• updated spare parts list
C	2025-04-14	01442	MW	<ul style="list-style-type: none">• scale description is corrected (pg. 21)• updated spare parts list (pg. 15)

9 APPENDIX A: INSTALLATION DIMENSIONS

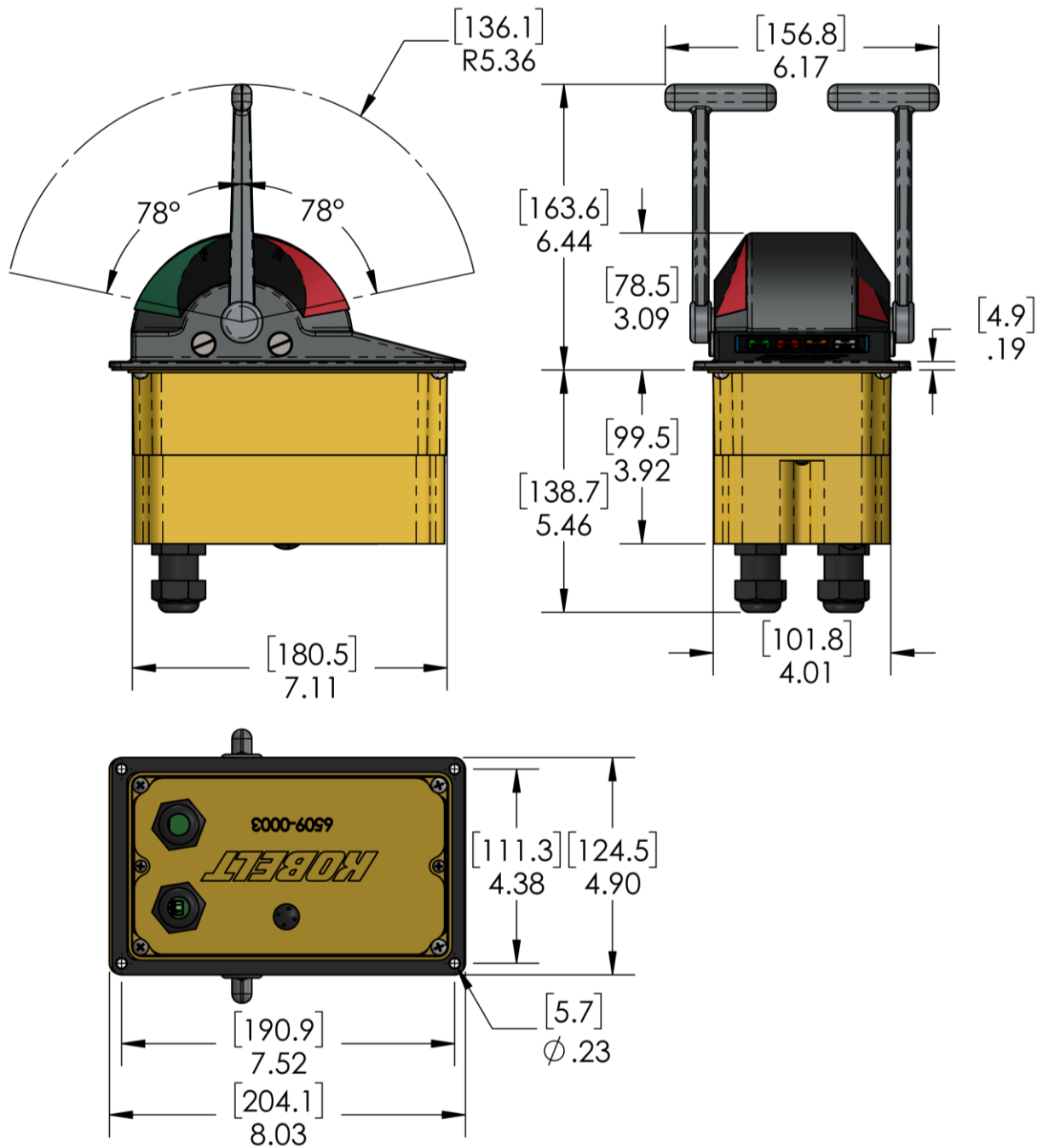

10 APPENDIX B: PARTS LIST

6509S-TB

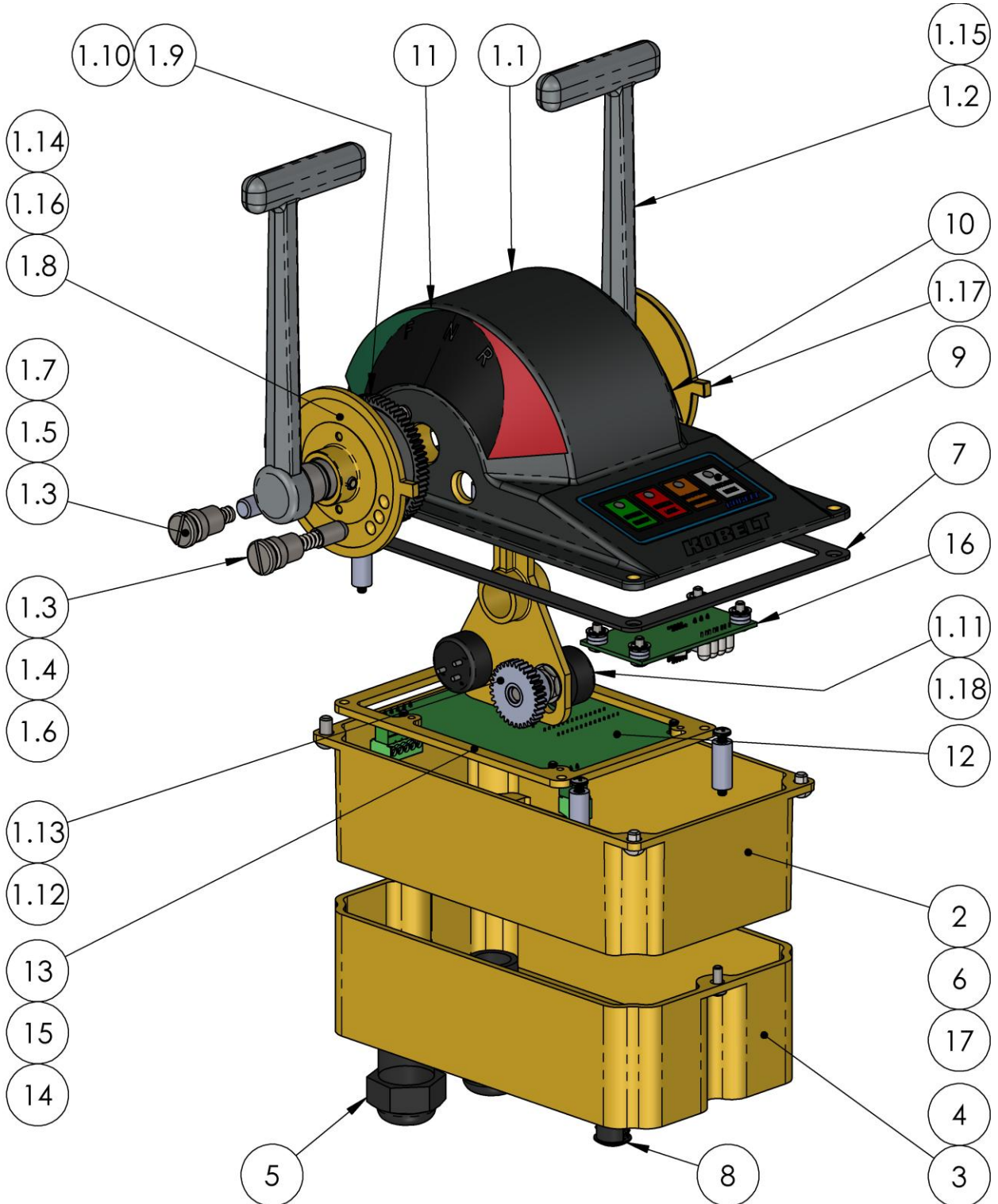

ITEM	QTY.	PART NUMBER	DESCRIPTION
1	1	6509-TB-SUB	SUB ASSEMBLY - CONTROL HEAD; TWIN ENGINE / STD CAMS / BLACK
1.1	1	6509-0001BT	6509 DOME, TEXTURE BLACK
1.2	2	6509-0014M-K	6509 HANDLE, CHROME
1.3	4	6509-0007	DETENT PLUG; 1/2 UNF
1.4	2	1201-0062	COMPRESSION SPRING; .25OD X .05 WIRE X .75 FL
1.5	2	1201-0205	COMPRESSION SPRING; .25OD X .041IN WIRE X .52IN FL
1.6	2	2545-0012	DETENT PIN
1.7	2	2545-0021	FRICTION BUTTON
1.8	1	6509-0004L	CAM, LEFT HAND, 3 DETENTS
1.9	2	YP-3264-1	SPUR GEAR - DELRIN; 32DP - 64T, STYLE A
1.10	4	1012-0606	SCREW, PAN HD, PHL DRIVE, 6-32 x 3/8IN, 18-8 SS
1.11	2	POT-5	POTENTIOMETER; 5K / 340DEG / 22MM / SLOTTED SHAFT
1.12	2	1023-0214	SHIM WASHER; 10MM X .625 X .032 IN / 18-8
1.13	2	YPB-3232	SPUR GEAR - DELRIN, 32T, 32DP, 1/4IN ID, B-STYLE
1.14	2	1016-0804	SET SCREW - SKT HD CUP PT; #10-24 X 1/4 LG / 18-8
1.15	2	1101-0014	O-RING, 2-014, 1/2IN X 1/16IN, NBR70
1.16	2	1024-0816	PIN; SLOTTED SPRING; 3/16 DIA X 1LG; AISI 304
1.17	1	6509-0004R	CAM-CONTROL HEAD; RIGHT HAND
1.18	2	6639-0001	SHIM WASHER, 10MM X 2MM, AISI 304
2	1	6509-0002	BOX SPACER
3	1	6509-0003	COVER
4	2	1012-0606	SCREW, PAN HD, PHL DRIVE, 6-32 x 3/8IN, 18-8 SS
5	2	6009-7840	CABLE GLAND, 1/2 NPT, .27 - .48 CORD, NYLON
6	2	1010-0804	RND HD PHILIPS MS, 10-24 X 1/4, 18-8
7	1	6509-0018	GASKET
8	1	6001-0310	VENT PLUG
9	1	6012-0016	MEMBRANE; STATION SELECT/LOCK/THROTTLE OVERRIDE / SYNCHRO MODE
10	1	6509-0015	SCALE, R-N-F, R.H
11	1	6509-0016	SCALE, R-N-F, L.H
12	1	6505-2001	BOARD ASSEMBLY; MIGHTY MARINER CONTROL HEAD
3	1	6509-0025	SPACER; CONTROL HEAD ELECTRICAL BOX
14	4	1012-0616	SCREW, MACHINE, PAN HD PHILLIPS, 6-32 X 1, SS
15	4	6009-7853	SPACER; 5/16OD X 3/4H X #8 / NYLON
16	1	6509-0009	PCBA; INTERFACE BOARD / 4 SWITCH
17	2	1010-0806	SCREW, RND HD PHL, 10-24 X 3/8, 18-8 SS

11 APPENDIX C: INSTALLATION CUT-OUT TEMPLATE

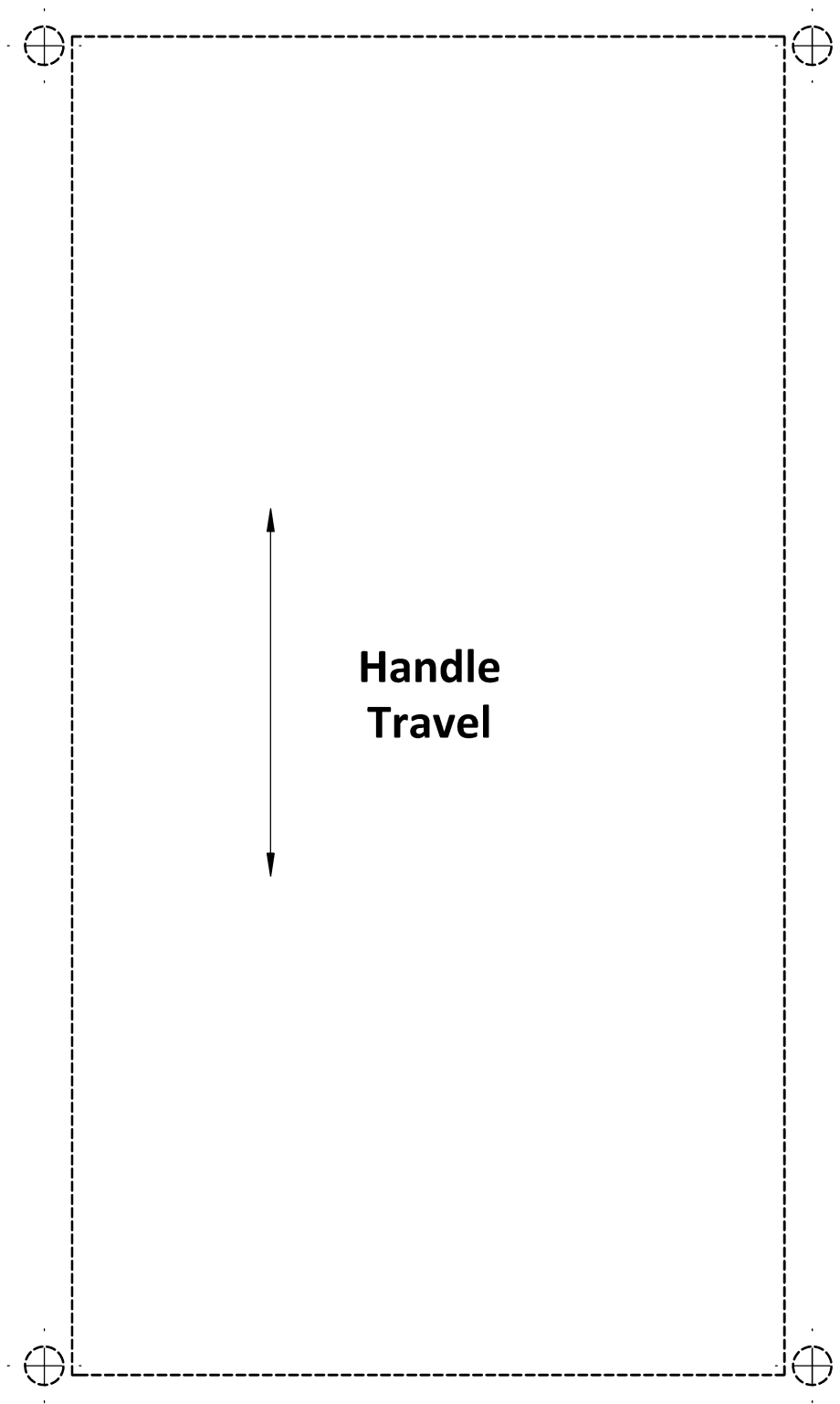

NOTICE

Scale may not be exactly 1:1 due to PDF and printer scaling. Verify primary dimension with a ruler after printing and before using to cut.

Reference [Appendix A: Installation Dimensions](#) , for the cut-out dimensions.

KOBELT

Kobelt Manufacturing Co. Ltd.

8238 129th Street
Surrey, British Columbia,
Canada, V3W 0A6

Sales Tel: +1-604-572-3935

Fax: +1-604-590-8313

Email: sales@kobelt.com

Website: www.kobelt.com