

# ***KOBELT***

## ***7163 Rudder Feedback Unit***

### ***Owner's Operation, Installation & Maintenance Manual***

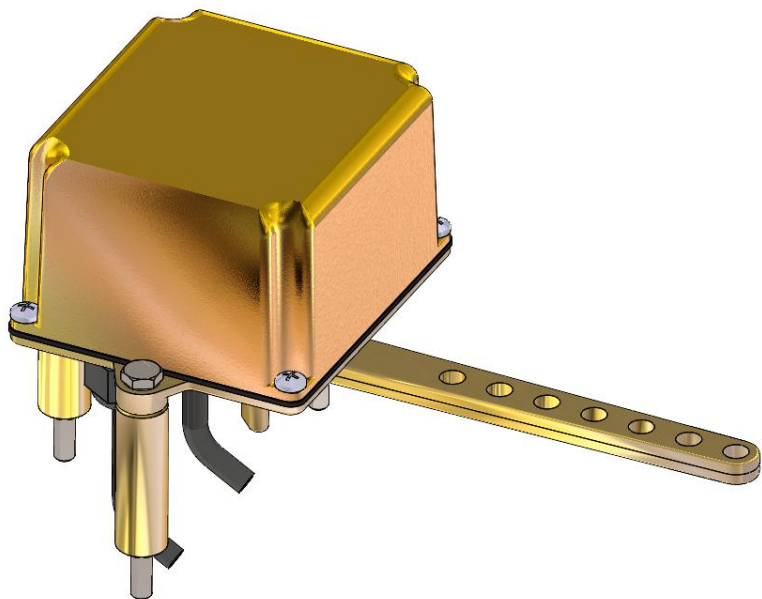



# TABLE OF CONTENTS

---

<b>1</b>	<b>Introduction .....</b>	<b>5</b>
1.1	Contact .....	5
1.2	Compliant Use .....	5
1.3	Copyrights & Trademarks .....	5
<b>2</b>	<b>Safety .....</b>	<b>6</b>
2.1	Safety Alerts.....	6
2.2	Notice to Installer .....	6
2.3	Product Hazards.....	7
<b>3</b>	<b>Product Description .....</b>	<b>7</b>
3.1	Technical Specifications .....	7
3.2	Model Code Key.....	9
<b>4</b>	<b>Installation .....</b>	<b>10</b>
4.1	Receipt.....	10
4.2	Mechanical .....	10
4.2.1	Mechanical Linkage.....	10
4.3	Electrical .....	12
<b>5</b>	<b>Commissioning .....</b>	<b>16</b>
5.1	Electrical Check.....	16
<b>6</b>	<b>Maintenance .....</b>	<b>17</b>
6.1	Preventative Maintenance.....	17
6.2	Service .....	17
6.2.1	Rudder End-stop Switches .....	17
6.2.2	Potentiometer Centering .....	17
6.3	Recommended Spare Parts.....	18
<b>7</b>	<b>Troubleshooting .....</b>	<b>18</b>
<b>8</b>	<b>Warranty.....</b>	<b>20</b>
<b>9</b>	<b>Revision History.....</b>	<b>21</b>
<b>10</b>	<b>Appendix A: Installation Dimensions.....</b>	<b>22</b>
<b>11</b>	<b>Appendix B: Parts List .....</b>	<b>23</b>
11.1	Parts List Notes: .....	25
<b>12</b>	<b>Appendix C: Determining RFU Generation and Required Retrofits .....</b>	<b>26</b>
12.1	Determination of microswitch generation .....	26

---

12.2 Determination of Required Retrofit Kit..... 27

**13 Appendix D: Installing Microswitch Retrofit Kit ..... 28**

---

# 1 INTRODUCTION

---

## 1.1 CONTACT

**Kobelt Manufacturing Co. Ltd.**

8238 129th Street  
Surrey, British Columbia  
Canada, V3W 0A6

Sales Tel: +1-604-572-3935

Fax: +1-604-590-8313

Email: [sales@kobelt.com](mailto:sales@kobelt.com)Website: [www.kobelt.com](http://www.kobelt.com)

This document is intended to clearly present comprehensive product data and provide technical information to assist the end user in design applications. Kobelt reserves the right, without notice, to change the design, or construction, of any products and to discontinue or limit distribution of any products. Kobelt also reserves the right to change, or update, without notice, any technical information contained within this document.

Kobelt recommends that customers visit our website to check for updates to this Manual. Once a product has been selected for use, it should be tested by the user to ensure proper function in all possible applications. For further instructions, please contact our distributors or visit our website.

## 1.2 COMPLIANT USE

This device is only intended for use by persons trained in operating marine systems.

The installer shall:

- Only use non-defective products.
- Check the safety of operation and the condition of the device before each use.
- Verify that the product is operational at all times and keep it in good working conditions.

Only Kobelt Manufacturing Co. Ltd. Authorized Dealers or Authorized Technicians are to repair Kobelt products.



## 1.3 COPYRIGHTS & TRADEMARKS

All product names, logos and brands are property of their respective owners. All company, product and service names used in this manual are for identification purposes only. Use of these names, logos, and brands does not imply endorsement.

## 2 SAFETY

### 2.1 SAFETY ALERTS

Throughout this manual, the following symbols, and their accompanying explanation, are used to alert the user to special instructions concerning a service or operation that may be hazardous if performed incorrectly or carelessly. The associated risk levels are stated below.

 <b>DANGER</b>	This symbol indicates an imminently hazardous situation which, if not avoided, will result in death or serious injury.
 <b>WARNING</b>	This symbol indicates a potentially hazardous situation which, if not avoided, could result in death or serious injury.
 <b>CAUTION</b>	This symbol indicates a hazardous situation, which if not avoided, could result in minor or moderate injury.
<b>NOTICE</b>	This symbol informs the reader of events not related to personal injury but which there is a risk of damage to property or equipment.
<b>SAFETY INSTRUCTIONS</b>	This symbol informs the reader of safety-related instructions or procedures.



### 2.2 NOTICE TO INSTALLER

Disregarding the following safety measures can result in an accident, causing severe injury to personnel and damage to material assets.

- Only use the product as directed in this manual.
- Never put the product into service if there is evidence of visible damage.
- Never put the product into service before fully completing installation and commissioning.
- Do not carry out any modifications to the product.
- Only use authentic Kobelt spare parts.
- Observe all local regulations, directives, and laws during the installation of this product.
- All installation, commissioning, and maintenance work must only be conducted by qualified personnel. (For the purpose of this manual, qualified personnel are persons who are familiar with the assembly, installation, commissioning, and operation of the product and who have the qualifications necessary for their occupation.)

- Observe all specifications in this manual. If these guidelines are not followed and damage occurs, the warranty will be voided.

## 2.3 PRODUCT HAZARDS

 <b>WARNING</b>	<b>Disconnect Power:</b> Turn off power at distribution panel before beginning installation to protect installer from electrical hazards.
 <b>CAUTION</b>	<b>Voltage and Current Compatibility:</b> Confirm that the power source is compatible with the maximum voltage and current ratings of is product variant. Failure to do so could result in damage or fire.

## 3 PRODUCT DESCRIPTION

The Kobelt 7163 Rudder Feedback Unit (RFU) can be configured to have up to three potentiometers and two rudder end stop switches per side. It can be used as an input to Full Follow Up (FFU) electronic steering systems, autopilots, and rudder angle indicators. Movement of the rudder adjusts the internal potentiometer(s). The 7163 Rudder Feedback Unit can be used for steering applications, other marine applications, or industrial installations. The 7163 is designed for indoor and outdoor installation with a robust die cast bronze and stainless-steel construction to provide a long service life in a harsh marine and salt-water exposed environment.

### 3.1 TECHNICAL SPECIFICATIONS

Table 1: 7163 Technical Data – Standard Variants

MODEL	7163		
KOBELT PART #	7163-A	7163-B	7163-C
POTENTIOMETER	1k $\Omega$	2x 1k $\Omega$	3x 1 k $\Omega$
MAX. POTENTIOMETER POWER	1 W		
SWITCH CONTACTS	2x SPDT	2x SPDT	2x SPDT
CONTACT RATINGS	250VAC – 10A		
CONNECTIONS	1x 3C/18 Pigtail 1x 4C/18 Pigtail	1x 6C/22 Pigtail 1x 4C/18 Pigtail	1X 9C/22 Pigtail 1X 4C/18 Pigtail
OPERATING TEMPERATURE	-25°C to 70°C [-13°F to 158°F]		
PRODUCT WEIGHT	2.1 kg [4.7 lbs]		
SURFACE FINISH	Plain Bronze		

Technical data and specifications are also available from our datasheet posted on [www.kobelt.com](http://www.kobelt.com) or the technical drawings in [Appendix A](#).

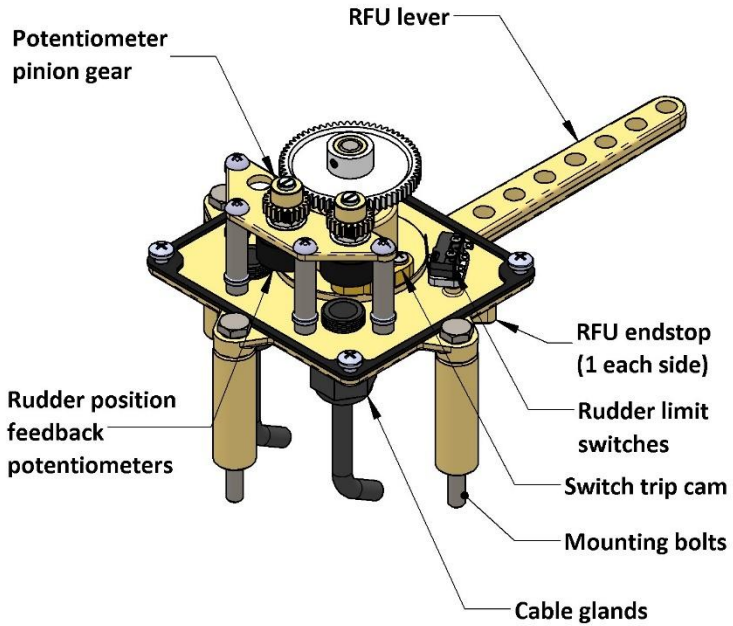

**Note: RFU shown with cover removed.**

*Figure 1: Product overview, 7163-B shown*

## 3.2 MODEL CODE KEY

### Model Code Key

7163- ← (list in alphabetical order)

#### Output Options

- A = 1 potentiometer + 2 switches
- B = 2 potentiometers + 2 switches
- C = 3 potentiometers + 2 switches
- G = 4 switches
- P = 1 potentiometer
- PP = 2 potentiometer

## 4 INSTALLATION

### 4.1 RECEIPT

Kobelt offers the 7163 rudder feedback unit in several configurations (reference [section 3.2](#)). Upon receipt of the device ensure that the model number and serial number are noted on the table in page 2 of this manual. The serial number can be found in the location noted in Figure 2. This model number will determine what spare parts are applicable.

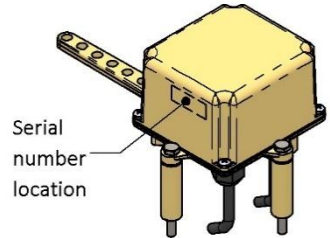

Figure 2: Part Identification

### 4.2 MECHANICAL

Ideally, the Rudder Feedback Unit should be mounted as close as possible to the tiller arm. Excessive lengths of connecting rods will lead to flexing and inaccuracies in the reported rudder position.



**CAUTION**

Minimize the connecting rod length to minimize errors in reported rudder position.

The Rudder Feedback Unit is equipped with (3) three ¼ UNC screws installed through the top surface for direct mounting. Reference the general arrangement drawing in [Appendix A](#) for the bolt pattern.

#### 4.2.1 Mechanical Linkage

The RFU lever is provided with seven 5/16" [8mm] diameter holes on a 5/8" [16 mm] pitch. Select the outer most hole on the RFU lever possible to minimize errors arising from backlash. Locate the connecting rod position on the tiller arm to ensure that rudder stop limit switches trip without crashing into the RFU end stops (+/-45°). Follow Table 2 to ensure that the gearing between rudder movement and RFU are synchronized.

Table 2: RFU / tiller synchronization

7163		
Rudder HO Angle	Travel Ratio	Dimension 'R' in [mm]
35	1.23:1	8.24 [209]
37	1.17:1	7.86 [200]
40	1.10:1	7.36 [187]
42	1.05:1	7.06 [179]
45	1.00:1	6.69 [170]
47	0.96:1	6.47 [164]

When installing the RFU remember to follow these tips:

- Ensure  $90^\circ$  relationships between the tiller arm, RFU lever and connecting link are maintained with the rudder in mid-ships position during alignment of all mechanical components.
- Ensure rudder feedback arm and rudder stock clamp swing equally on each side of mid-ships position.
- Locate 7163 Rudder Feedback Unit near rudder stock on a level surface.
- The threaded connection rod may need to be adjusted to achieve the correct mounting geometry.

Reference Figure 3 for clarification.

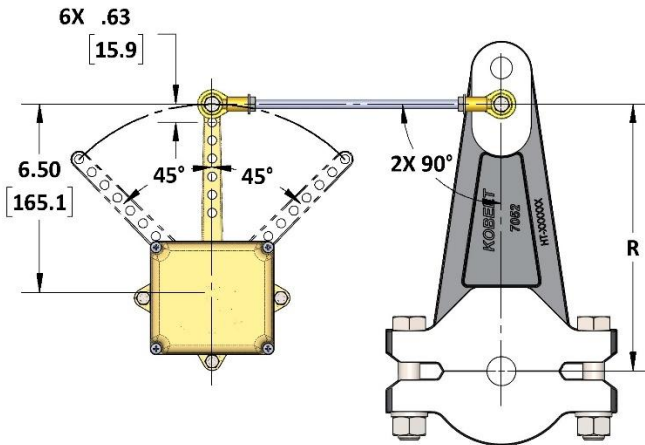

Figure 3: RFU installation

Note: Connection kits are available from Kobelt (P/N: 7174-010X).

## 4.3 ELECTRICAL

When making the electrical connections, locate the electrical junction box;

- Within 6 feet [1.8 m] of the rudder feedback unit.
- Placed to protect external electrical cable from damage.

The cable gland locations are located on the bottom of the unit and are shown in Figure 1. The internal potentiometer wire connections are shown in Figure 4. Figure 5-Figure 7 depict the wiring assignment by color for various potentiometer arrangements of two limit switch models. Four limit switch configurations are shown in Figure 8. Identify your specific configuration and refer to the appropriate diagram.

The operating direction of the Potentiometer in relation to the Rudder Feedback Unit handle is shown in Figure 8.

A sample pin out for a single potentiometer model is given in Table 3. Models with more than one potentiometer will have different wire coloring. Figure 5-Figure 7 should be consulted for the wire colouring of models with more than one potentiometer.

*Table 3: 7163 Wire Connections*

7163				
Wire #	Wire Name	Colour	Gauge	Function
1	POT+	White	18AWG	FFU potentiometer power supply connection.
2	POT WIPER	Red	18AWG	FFU potentiometer signal connection.
3	POT-	Black	18AWG	FFU potentiometer ground connection.

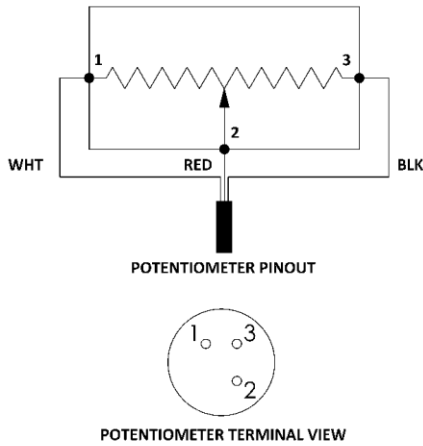

Figure 4: 7163 Potentiometer Wiring Diagram

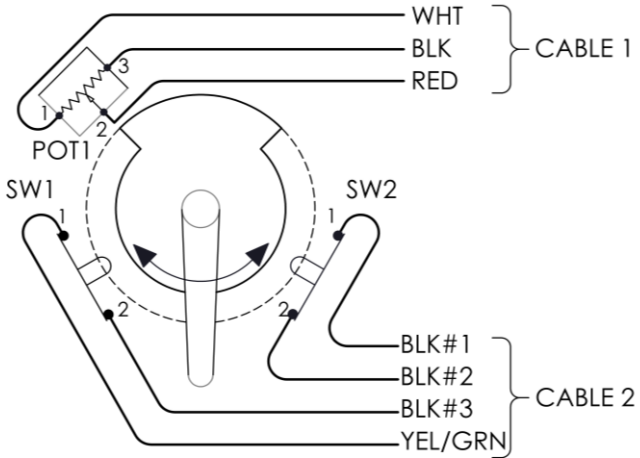

Figure 5: 7163-A wiring

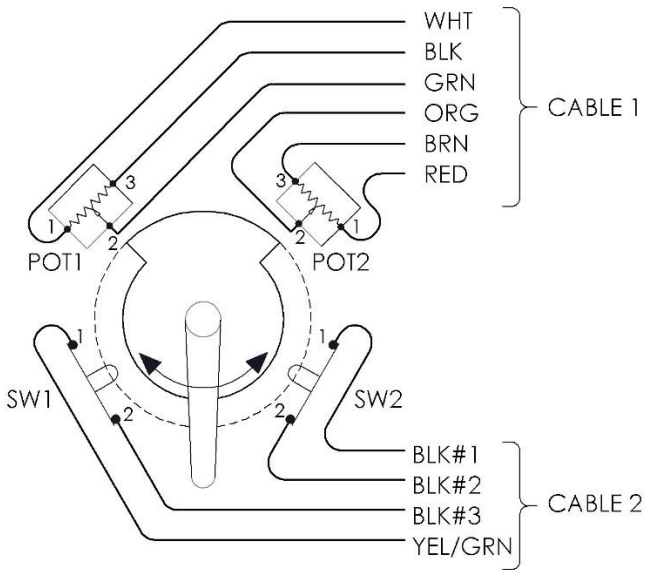

Figure 6: 7163-B wiring

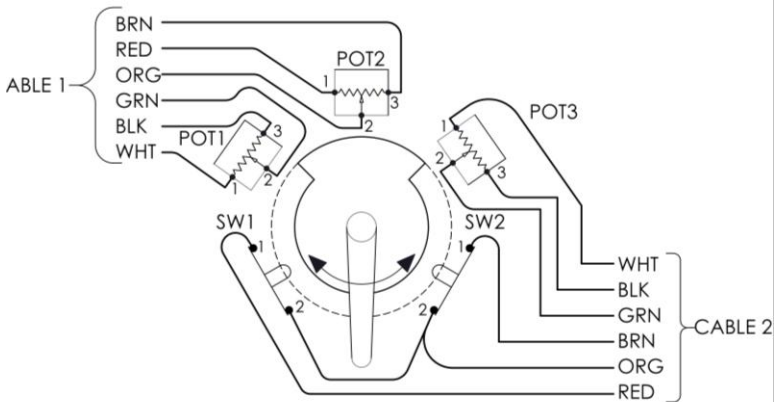

Figure 7: 7163-C wiring

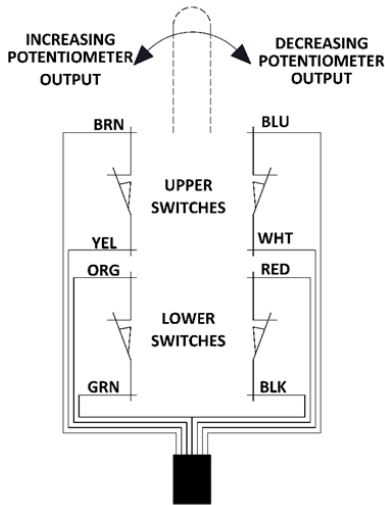

Figure 8: 7163-( )G Internal Wiring Diagram

NOTICE	<p>When wiring the rudder end stop switches directly to the steering solenoid valves, it is recommended to place a 1N4007 protection diode across the coil terminals.</p>
--------	---

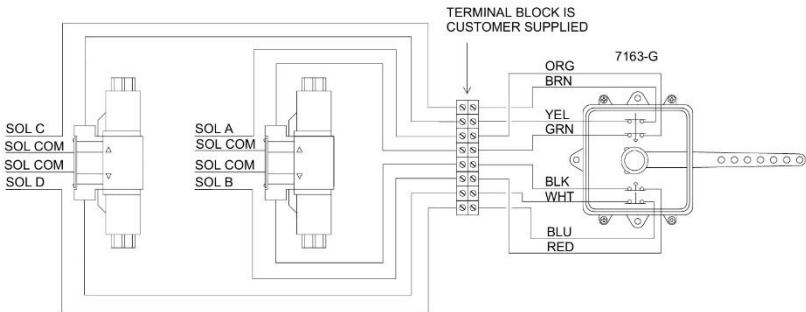

Figure 9: 7163-G Limit Switch Wiring Diagram

<b style="font-size: 24px; margin-left: 5px;">WARNING</b>	<p>Failure to use a TVS diode when switching solenoid coils will reduce the life of the rudder end stop switches.</p>
---	---

---

## 5 COMMISSIONING

---

### 5.1 ELECTRICAL CHECK



#### CAUTION

Ensure that the rear cover is installed and secured before powering on the 7163.

- Confirm that the electrical connections to the 7163 have been made.
- Confirm that port and starboard rudder movements are displayed correctly at the rudder angle indicators.
- Confirm that the rudder range of motion is reported correctly to the rudder angle indicators and steering controller.
- Ensure that the rudder end stop switches trip before the rudder or RFU lever impacts the rudder stops. See [section 6.2.1](#) for adjusting.



#### CAUTION

The Functional Test should be carried out while the vessel is still at dock and before it is taken out to sea after installation has been completed.

## 6 MAINTENANCE

### 6.1 PREVENTATIVE MAINTENANCE

- Quarterly (4 times/year)
  - Visually inspect wire and cable insulation for splits or damage.
  - Ensure there is no visible corrosion on the unit.
  - Confirm that the rudder angle indicators indicate zero degrees when the rudder is centered.
- Every (2) two years
  - Confirm all electrical screw terminals are secured.
  - Confirm cable glands are secured to cables.

### 6.2 SERVICE

#### 6.2.1 Rudder End-stop Switches

To adjust the rudder end-stop trip position follow these instructions:

1. Position the rudder to the desired trip position.
2. Remove the RFU cover.
3. Locate the relevant switch trip cam (see- Figure 1).
4. Loosen the two screws and rotate the cam until the switch just trips and secure the two screws.
5. Repeat for the other switch.

#### 6.2.2 Potentiometer Centering

When replacing the potentiometer or if the setting has become disturbed, follow these steps to center the output:

1. Position the rudder in the center (dead ahead) position.
2. Remove the RFU cover.
3. Locate the potentiometer in need of centering (see - Figure 1).
4. Connect a multimeter to the Pot – (white wire) and the Pot Wiper (green wire). Set the meter to read resistance.
5. Loosen the two locking set screws on the pinion gear with a 1/16-inch Allen key.

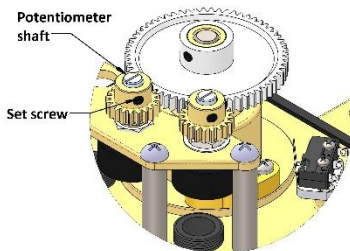

6. Using a short flat head screwdriver, rotate the potentiometer shaft until the meter reads half of the rated output (500 ohms for a 1K potentiometer).
7. Tighten the two locking set screws and replace the cover.

## 6.3 RECOMMENDED SPARE PARTS

Depending on the severity and criticality of service, it may be necessary to keep spare potentiometers on hand.

When purchasing replacement parts refer to Appendix B: Parts List at the back of this manual for Kobelt component Part Numbers.

### NOTICE

It is recommended that any required service work on a Kobelt product be performed by a factory authorized service representative. Please contact the nearest Kobelt authorized distributor for assistance.

## 7 TROUBLESHOOTING

If you encounter problems with the operation of your product, please refer to the troubleshooting suggestions before contacting Kobelt for assistance. If the steps below do not resolve your issue, please reach out either Kobelt directly or our Dealers in your area.

Table 4: Common Solutions

Problem (Issue encountered)	Cause (What it means)	Corrective Action (What to do)
<b>Rudder Feedback Unit action is reversed.</b>	Wiring is backwards.	Swap the POT+ and POT- output wires to their respective system connections.
<b>Rudder Feedback Unit does not move rudder at all.</b>	The rest of the system isn't hooked up correctly.	1. Check system wiring. 2. Confirm wiring to Rudder Feedback Unit.
	Broken potentiometer or contact.	1. Use a multi-meter to monitor the resistance of the wiring between potentiometer contacts. 2. Check for normal operation of the potentiometer by measuring the connection while moving the Rudder Feedback Unit.

		3. Check potentiometer directions. 4. Replace any damaged potentiometers.
	Wiring is wrong.	Check wiring against User Manual wiring diagrams for Feedback Unit and connected Products.

---

## 8 WARRANTY

---

Kobel Manufacturing Co. Ltd. (“Kobel”) warrants the Products and Parts manufactured by Kobel to be free from defects in workmanship or material and that said products are designed mechanically and functionally to perform to specifications.

This warranty is effective providing:

- The equipment is used within the intended operating conditions and in accordance with Kobel recommendations.
- The equipment is installed according to equipment diagrams, specifications, and recommendations which Kobel has provided.

This warranty becomes invalid if the factory supplied serial number has been removed or altered on the product. This warranty does not cover cosmetic damage or damage caused by an act of God, accident, misuse, abuse, negligence, or modification of any part of the product. This warranty does not cover damage due to improper operation or maintenance, connection to inappropriate equipment or attempted repair by anyone other than an authorized Kobel representative.

Upon identification of a potential issue or defect with a Kobel Product or Part, the Warranty Applicant (“Applicant”) must immediately contact Kobel and describe the issue in writing, by letter, fax, email, or other electronic conveyance. Kobel will then assess the cause of the defect and determine warranty applicability and appropriate remediation.

If any part is found to be defective, Kobel will replace said part FOB the Kobel factory provided that any such defective part is returned by the Buyer with freight and applicable forwarding charges prepaid by the Buyer. Kobel’s sole obligation to the Applicant will be to repair or replace the defective part with same or similar product, to a maximum value of the list price of the product or part. The Kobel warranty does not cover labour charges, travel or any other associated expenses.

All Products and Parts manufactured by Kobel, are subject to a warranty against manufacturer’s defects in materials or workmanship for a period of two (2) years from the date of purchase.

Kobel will be responsible for all Products or Parts sold by Kobel but manufactured by 3<sup>rd</sup> party manufacturing companies. However, these products and parts are subject to applicable 3<sup>rd</sup> party warranties and may not be the same as the Kobel warranty.

## 9 REVISION HISTORY

Table 5: Table of revision changes

Document Revision	Release Date	ECN	Author	Revision Summary
A	2024-03-01	00986	GG	<ul style="list-style-type: none"><li>Initial release</li></ul>
B	2024-08-15	01066	HE	<ul style="list-style-type: none"><li>Swapped Pot 3, pins 2 &amp; 3 wire colors</li></ul>
C	2026-04-21	01439	MW	<ul style="list-style-type: none"><li>Section 4.3 Electrical: Added limit switch wiring details</li></ul>

# 10 APPENDIX A: INSTALLATION DIMENSIONS

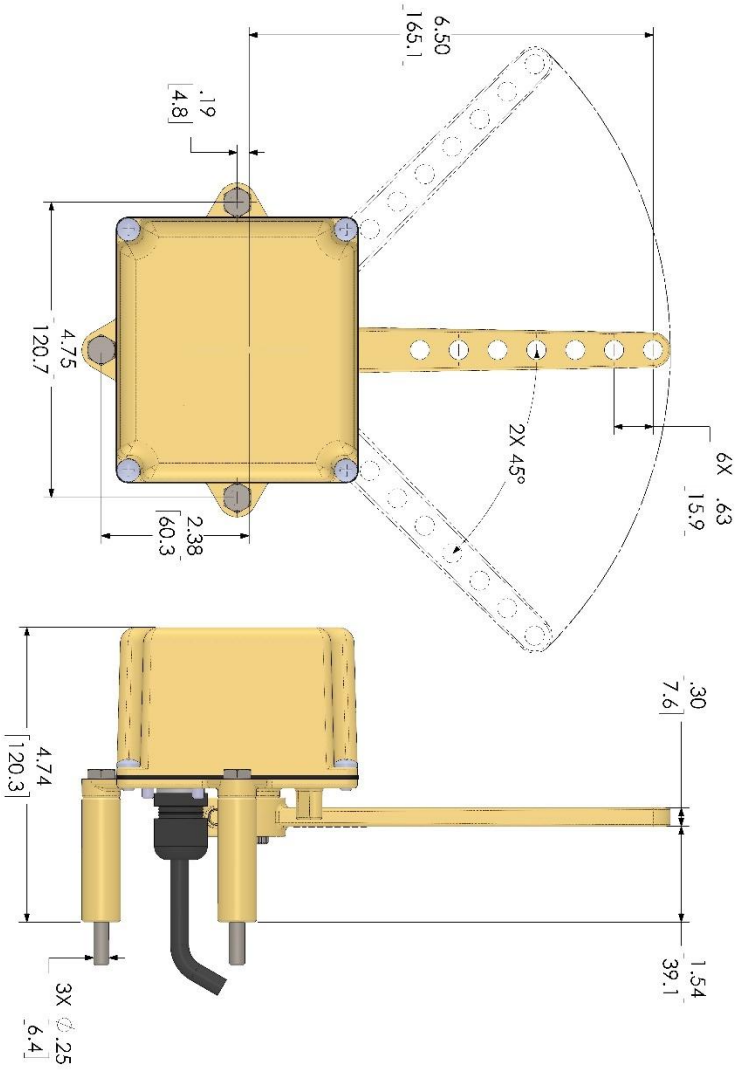

# 11 APPENDIX B: PARTS LIST

## 7163-B

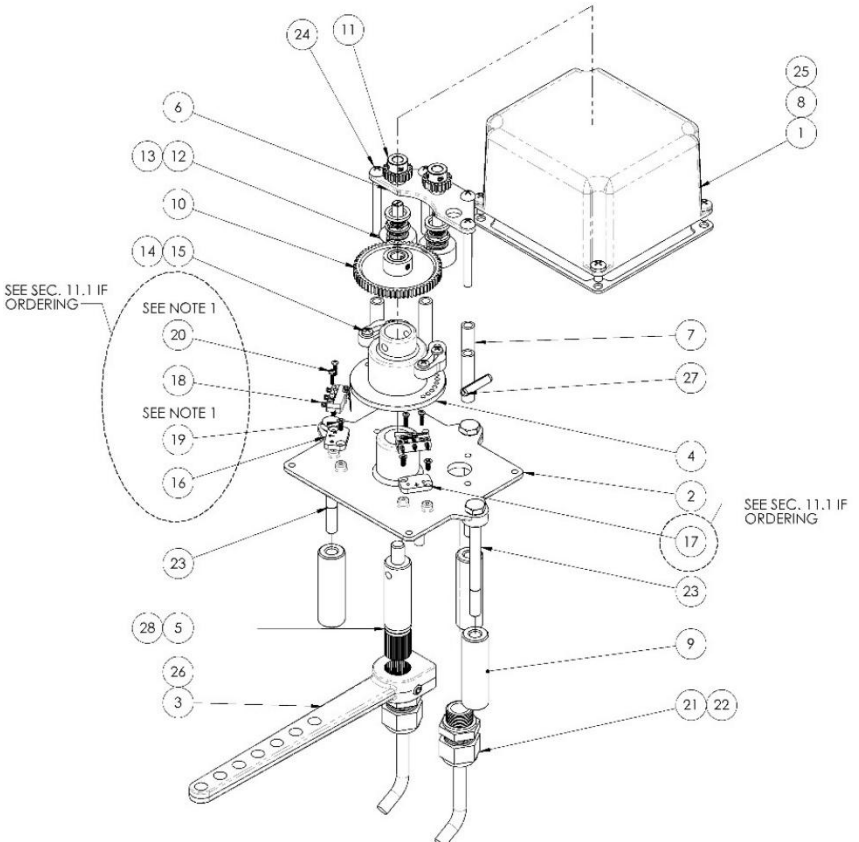

Figure 9: 7163-B Parts Diagram

Table 6: BOM for 7163-B

ITEM	QTY.	PART NUMBER	DESCRIPTION	NOTES (SEC. 11.1)
1	1	7163-0001	HOUSING	-
2	1	7163-0002	COVER	-
3	1	7163-0003	LEVER	-
4	1	7163-0004	CAM PLATE	-
5	1	7163-0006	SHAFT	-
6	1	7163-0007	POT PLATE	-
7	4	7163-0008	SPACER	-
8	1	7163-0009	GASKET	-
9	3	7174-0009	SPACER, BRASS	-
10	1	YPB-3264	SPUR GEAR 64T DERLIN W/ 5/16 BRASS INSERT	-
11	2	Y-3220	SPUR GEAR - BRASS; 32P/20T/B STYLE/.250IN BORE + 2 SET SCREWS	-
12	2	POT-1	POTENTIOMETER, 1K, 1TURN, 340 DEG, 22MM DIA	-
13	2	6639-0001	SHIM WASHER, 10MM X 2MM, AISI 304	-
14	2	7163-0005	CASTING, CAM	-
15	4	1012-0606	SCREW, PAN HD, PHL DRIVE, 6-32 x 3/8IN, 18-8 SS	-
16	1	7174-0014	BRACKET, MICROSWITCH, 7174	1
17	1	7170-0011	BRACKET, MICROSWITCH	1
18	2	6001-0112	MICRO SWITCH, SUBMINIATURE, STRAIGHT LEVER, SPDT 10A	1
19	4	1009-0304	SCREW, FLAT HD, PHP DR, 3-48 X 1/4, 18-8	1
20	4	1012-3208	SCREW, PAN HD, PHP DR, M2-0.4 X 8, 18-8	1
21	2	6001-0248	CABLE GLAND; M16 X 1.5, .197-.394 CABLE, PA6, BLACK	-
22	2	6001-0248-W- M16	WASHER, SEALING, M16, POLYETHYLENE	-
23	3	1001-1048	1/4-20 X 3.0, HEX HD. CAPSCREW, 18-8	-
24	4	1010-0828	SCREW, RND HD, PHL, 10-24 X 1 3/4, 18-8	-

25	4	1010-0806	SCREW, RND HD PHILIPS, #10-24 X 3/8, GR. 8	-
26	1	1016-1006	SCREW; SET; SKT HEAD; CUP PT; 1/4-20 x 3/8; 18-8	-
27	1	1024-0814	SPRING PIN; 3/16 DIA X 7/8 LG, AISI 420	-
28	1	1101-0014	O-RING, 2-014, 1/2IN X 1/16IN, NBR70	-
29	1	6525W-B-RL	CABLE, 7C/18AWG, SHIELDED, 600V	-
30	1	6014-0002	CABLE; 4C/18AWG; 600C; GRY	

## 11.1 PARTS LIST NOTES:

1. Contained in microswitch retrofit kits: 7170-RF-01 or 7174-RF-01. See section 12.1 and section 12.2 to determine if a retrofit kit is required or can purchase standalone part, and which microswitch kit is required.

## 12 APPENDIX C: DETERMINING RFU GENERATION AND REQUIRED RETROFITS

### 12.1 DETERMINATION OF MICROSWITCH GENERATION

In early 2024, rudder limit microswitches in the 7163 RFUs were replaced with a new style of microswitch. The newer generation microswitch requires a mounting bracket and different hardware for its implementation. Customers with RFUs purchased prior to this change will require a retrofit kit if they are replacing the microswitch. The old style microswitch is Kobelt PN: 6001-0104 and is a bare plunger style microswitch. The new microswitch, Kobelt PN: 6001-0112, is a plunger style but with an actuation lever.

Determining what generation of microswitch is currently installed in your unit can be done by physically examining the microswitch and comparing to those shown in Table 5. If the RFU contains generation 1 microswitches and a replacement is required, it will be necessary to purchase a retrofit kit. There are two available retrofit kits available for the 7163 RFU. Determination of which kit is required is outlined in section 12.2. Each retrofit kit contains the switches and mounting components for one side of the RFU. If all microswitches are to be replaced, it will be required to order two retrofit kits.

Table 5: Microswitch generation determination

Key Features	Generation 1	Generation 2
Micro Switch part number	6001-0104	6001-0112
Picture		
Replacement part number	Retrofit kit: 7170-RF-01 Or 7174-RF-02 *See Figure 10	Microswitch only, 6001-0112

## 12.2 DETERMINATION OF REQUIRED RETROFIT KIT

There are two retrofit kits available, one for the left side microswitch, and one for the right side microswitch. Determination of which kit is required can be done by comparing the position of the microswitch that is broken with the image shown in Figure 10.

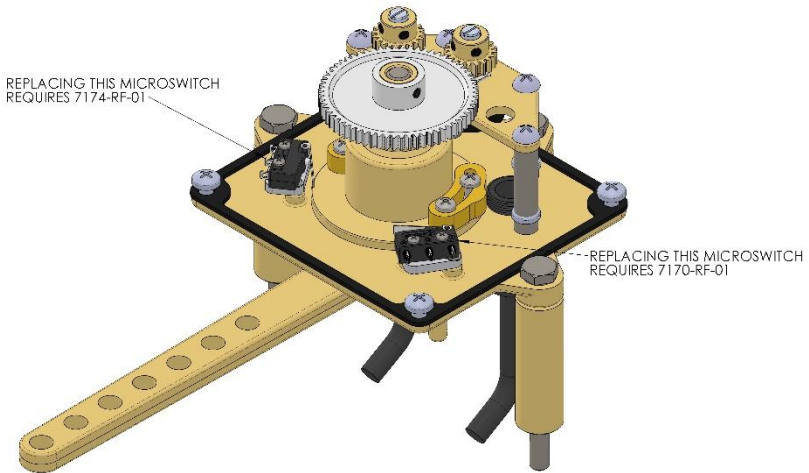

*Figure 10: 7163 Determining which microswitch kit is required.*

# 13 APPENDIX D: INSTALLING MICROSWITCH RETROFIT KIT

 <b>WARNING</b>	<p>Replacing the microswitches requires soldering as well as correct placement of the microswitches. This should only be done by Kobelt factory authorized service representatives. Failure to do so could result in a failure of the limit switch.</p>
<b>NOTICE</b>	<p>Before removing old microswitches, please ensure you have one retrofit kit for each side that has a microswitch being replaced. Review Figure 11-Figure 12 and Table 6-Table 7 and compare to your retrofit kits to ensure the correct quantities of components are present.</p>
<b>NOTICE</b>	<p>Please read through and review steps and all figures in section 13 before starting the removal of the old microswitch and installation of the new microswitch.</p>

Depictions and BOMs for the two retrofit kits are shown in Figure 11-Figure 12 and Table 6-Table 7 respectively. The only difference between these kits is the microswitch bracket part number. Installation of the kits is identical.

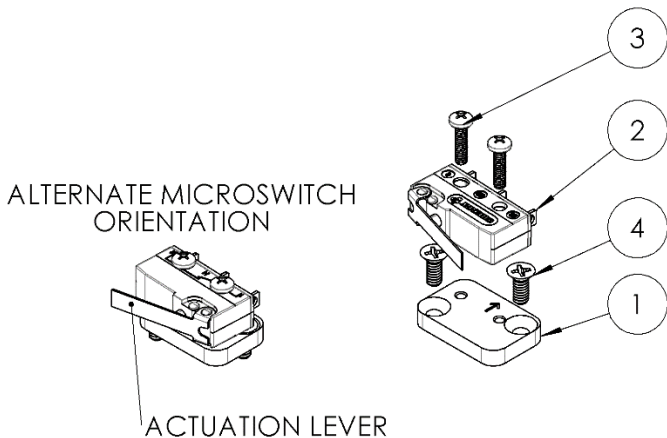

Figure 11: Microswitch retrofit kit, 7174-RF-01

Table 6: 7174-RF-01 BOM

7174-RF-01 BOM			
Item	Qty	Part Number	Description
1	1	7174-0014	BRACKET, MICROSWITCH, 7174
2	1	6001-0112	MICRO SWITCH, SUBMINIATURE, STRAIGHT LEVER, SPDT 10A
3	2	1012-3208	SCREW, PAN HD, PHP DR, M2-0.4 X 8, 18-8
4	2	1009-0304	SCREW, FLAT HD, PHP DR, 3-48 X 1/4, 18-8

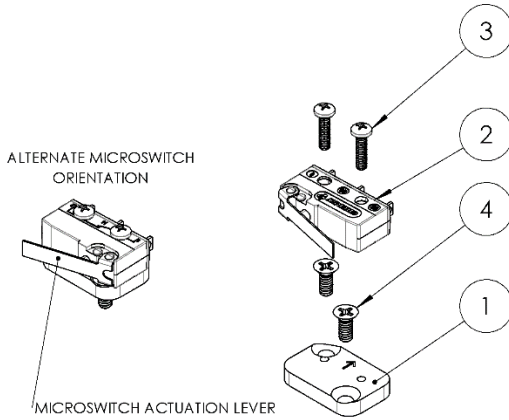

Figure 12: Microswitch retrofit kit, 7170-RF-01

Table 7: Bill of materials for Microswitch retrofit kit, 7170-RF-01

7170-RF-01 BOM			
Item	Qty	Part Number	Description
1	1	7170-0011	BRACKET, MICROSWITCH
2	1	6001-0112	MICROSWITCH, SUBMINIATURE, STRAIGHT LEVER, SPDT 10A
3	2	1012-3208	SCREW, PAN HD, PHP DR, M2-0.4 X 8, 18-8
4	2	1009-0304	SCREW, FLAT HD, PHP DR, 3-48 X ¼, 18-8

1. Note connections of all wires going to the old microswitches prior to disconnecting. It is recommended to fill out the colors of the wire going to each terminal on the diagram shown in Figure 13. On the old microswitch, Kobelt PN 6001-0104, the terminals are labelled 1 and 2, and correspond to terminals 1 and 2 on the new microswitches.

**IMPORTANT:** Two switch RFUs come from the factory with a four-cable conductor that contains three black wires and one green with yellow stripe. When noting the black wires, be sure include the number printed on the wire casing.

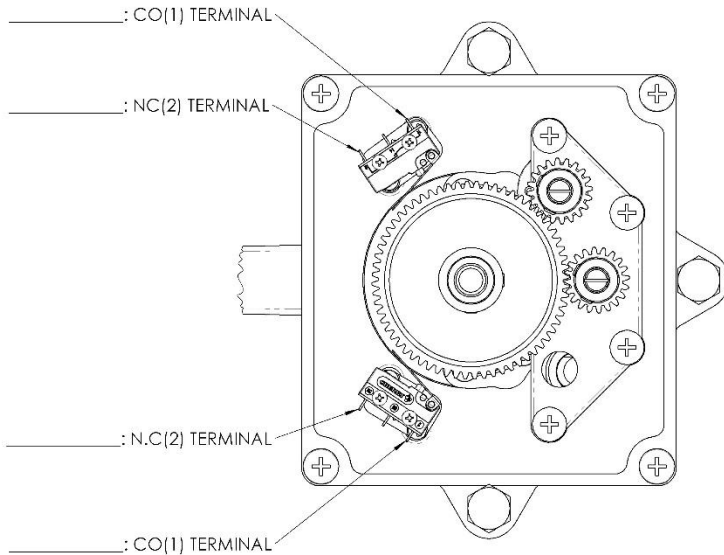

Figure 13: Wiring schematic for customer fill out

2. Desolder the wire connections on the old microswitch.
3. Remove and discard the old microswitch.
4. Refer to Figure 14 and note the engraved arrow on the microswitch bracket ① is facing outwards on both sides of RFU.
5. Apply Loctite 242(Blue) to X2 Flat head screws ④.

- 
6. Install bracket ① with screws ④ into the RFU cover plate, 7163-0002, ensuring the engraved arrow is correctly orientated.
  7. Refer to Figure 14 and note the orientation of the microswitch ② for the side of the RFU that the microswitch is being replaced on.
  8. Place the microswitch ② on top of the bracket ① orientating the microswitch so the actuation lever is as shown in Figure 14. For reference, the actuation lever is pointed to in Figure 11 and Figure 12.
  9. Apply Loctite 242(Blue) to X2 pan head screws ③.
  10. Use X2 screws ③ and tighten to secure the microswitch ②.

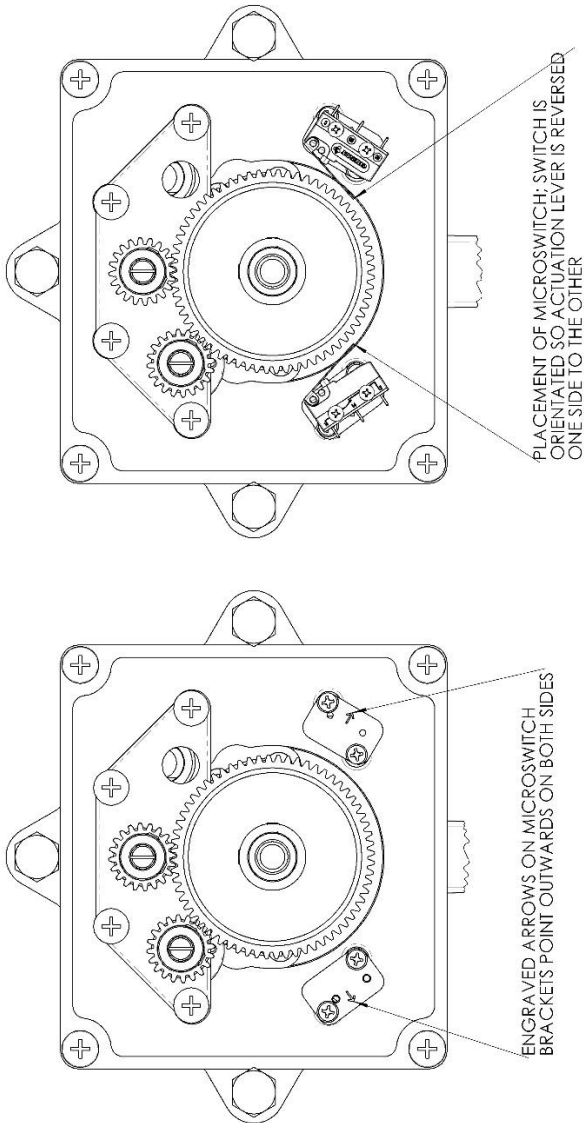

Figure 14: Placement of microswitch and microswitch bracket, 7163-B shown.

11. Review section 6.2.1 and set the switch trip cam(see Figure 1) in the correct position for the new microswitch.
12. Check correct operation of the switch by rotating the RFU lever through its full travel, ensure:
  - a. The actuation lever of microswitch ② is clear of any obstructions through its range of motion.
  - b. The microswitch ② actuation lever is depressed enough to actuate the switch contacts when the RFU is at its limit. This can be done by checking for no continuity across the Normally Closed(N.C) terminal 2 and the Common(C) terminal 1. See Figure 15 for clarity on terminals being checked. When the switch is depressed, terminal 1 and 2 should have no continuity.
  - c. The microswitch ② lever is raised enough to let the switch go to its normally closed position when the RFU is not at its limit. This can be done by checking for a closed circuit (continuity) across the Normally Closed and Common terminals. When the RFU lever is off its limit position, there should be continuity across terminal 1 and 2.

If conditions 'a', 'b' or 'c' are not met, loosen the switch trip cam and adjust its position until the microswitch is actuated and allowed to reset in the desired positions.

13. Prepare the wires for connecting to the new microswitch:
  - a. Ensure the wires are routed in the same manner as prior to beginning the retrofit.
  - b. Twist the pairs of wires going to each of the microswitches together or use cable ties to secure the wires together.
14. Solder the wires to the terminals of the new microswitches:
  - a. Follow the wiring connections that were noted in step one, Figure 13.
  - b. For reference the default factory wiring is given in Figure 15.
  - c. In case of discrepancy between the noted wiring and factory wiring, it is recommended to keep wiring as noted in Figure 13 as the wiring may have been altered in the field at original installation. This will ensure the RFU behaves in the same manner as prior to the retrofit.

15. It is recommended to apply heat shrink protective tubing to the exposed wire and connection terminals.
16. If the other microswitch is being replaced as well, repeat steps 1-15 on the other microswitch.
17. Refer to section 0 for recommissioning the RFU once all the faulty switches have been replaced.

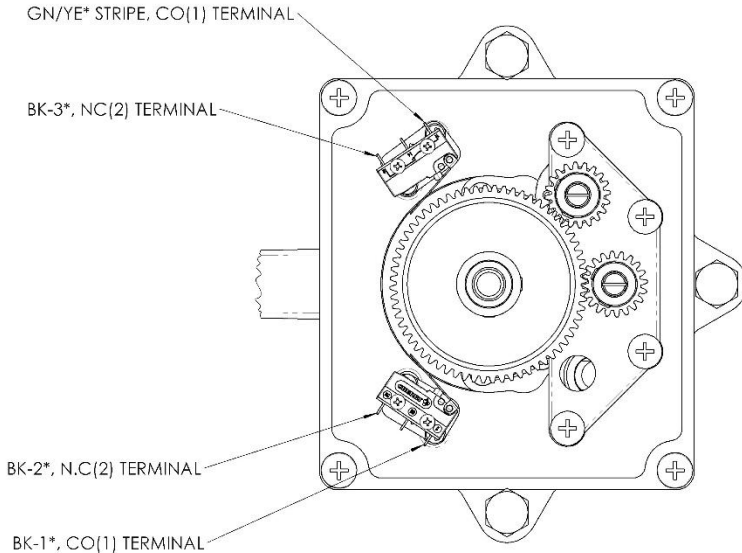

Figure 15: Default factory wiring diagram of new microswitches, 7163-B shown.

\*Confirm wiring colors with unit prior to retrofit.

(Intentionally Blank)

# ***KOBELT***

**Kobelt Manufacturing Co. Ltd.**

8238 129th Street  
Surrey, British Columbia,  
Canada, V3W 0A6

Sales Tel: +1-604-572-3935

Fax: +1-604-590-8313

Email: [sales@kobelt.com](mailto:sales@kobelt.com)

Website: [www.kobelt.com](http://www.kobelt.com)

Made in Canada / Printed in Canada