

KOBELT

7174 Rudder Feedback Unit

Owner's Operation, Installation & Maintenance Manual

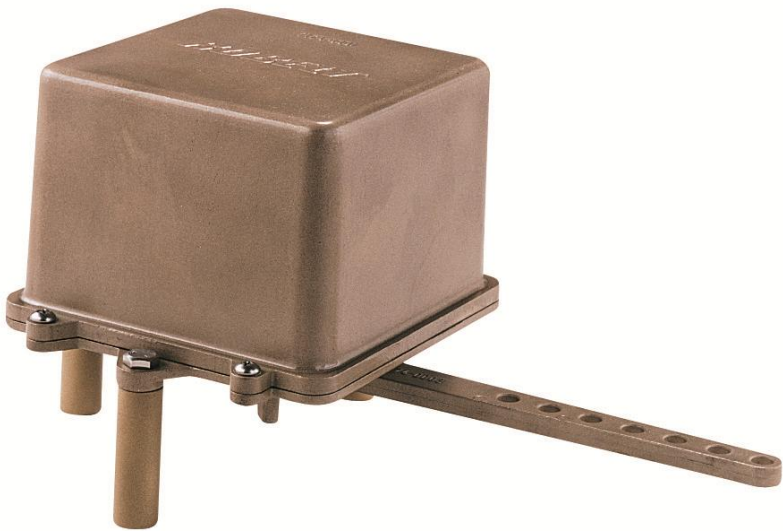

TABLE OF CONTENTS

1	Introduction	5
1.1	Contact	5
1.2	Compliant Use	5
1.3	Copyrights & Trademarks	5
2	Safety	6
2.1	Safety Alerts.....	6
2.2	Notice to Installer	6
2.3	Product Hazards.....	7
3	Product Description	7
3.1	Technical Specifications	7
3.2	Model Code Key.....	9
4	Installation	10
4.1	Receipt.....	10
4.2	Mechanical	10
4.2.1	Mechanical Linkage.....	10
4.3	Electrical	12
5	Commissioning	16
5.1	Electrical Check.....	16
6	Maintenance	16
6.1	Preventative Maintenance.....	16
6.2	Service	17
6.2.1	Rudder End-stop Switches	17
6.2.2	Potentiometer Centering	17
6.3	Recommended Spare Parts.....	18
7	Troubleshooting	19
8	Revision History.....	20
9	Warranty.....	21
10	Appendix A: Installation Dimensions.....	22
11	Appendix B: Parts List	23
11.1	Parts list notes:	31
12	Appendix C: Determining RFU Generation and Required Retrofits	32
12.1	Determination of microswitch generation	32

12.2	Determination of Required Retrofit Kit.....	33
13	Appendix D: Installing Microswitch Retrofit Kit	34
13.1	7174-RF-01 / 7174-RK-01 – Two Switch RFUs	34
13.2	7174-RF-02 / 7174-RK-02 – Four Switch RFUs.....	42

1 INTRODUCTION

1.1 CONTACT

Kobelt Manufacturing Co. Ltd.

8238 129th Street
Surrey, British Columbia
Canada, V3W 0A6

Sales Tel: +1-604-572-3935

Fax: +1-604-590-8313

Email: sales@kobelt.comWebsite: www.kobelt.com

This document is intended to clearly present comprehensive product data and provide technical information to assist the end user in design applications. Kobelt reserves the right, without notice, to change the design, or construction, of any products and to discontinue or limit distribution of any products. Kobelt also reserves the right to change, or update, without notice, any technical information contained within this document.

Kobelt recommends that customers visit our website to check for updates to this Manual. Once a product has been selected for use, it should be tested by the user to ensure proper function in all possible applications. For further instructions, please contact our distributors or visit our website.

1.2 COMPLIANT USE

This device is only intended for use by persons trained in operating marine systems.

The installer shall:

- Only use non-defective products.
- Check the safety of operation and the condition of the device before each use.
- Verify that the product is operational at all times and keep it in good working conditions.

Only Kobelt Manufacturing Co. Ltd. Authorized Dealers or Authorized Technicians are to repair Kobelt products.



1.3 COPYRIGHTS & TRADEMARKS

All product names, logos and brands are property of their respective owners. All company, product and service names used in this manual are for identification purposes only. Use of these names, logos, and brands does not imply endorsement.

2 SAFETY

2.1 SAFETY ALERTS

Throughout this manual, the following symbols, and their accompanying explanation, are used to alert the user to special instructions concerning a service or operation that may be hazardous if performed incorrectly or carelessly. The associated risk levels are stated below.



 DANGER	This symbol indicates an imminently hazardous situation which, if not avoided, will result in death or serious injury.
 WARNING	This symbol indicates a potentially hazardous situation which, if not avoided, could result in death or serious injury.
 CAUTION	This symbol indicates a hazardous situation, which if not avoided, could result in minor or moderate injury.
NOTICE	This symbol informs the reader of events not related to personal injury but which there is a risk of damage to property or equipment.
SAFETY INSTRUCTIONS	This symbol informs the reader of safety-related instructions or procedures.

2.2 NOTICE TO INSTALLER

Disregarding the following safety measures can result in an accident, causing severe injury to personnel and damage to material assets.

- Only use the product as directed in this manual.
- Never put the product into service if there is evidence of visible damage.
- Never put the product into service before fully completing installation and commissioning.
- Do not carry out any modifications to the product.
- Only use authentic Kobelt spare parts.
- Observe all local regulations, directives, and laws during the installation of this product.
- All installation, commissioning, and maintenance work must only be conducted by qualified personnel. (For the purpose of this manual, qualified personnel are persons who are familiar with the assembly, installation, commissioning, and operation of the product and who have the qualifications necessary for their occupation.)
- Observe all specifications in this manual. If these guidelines are not followed and damage occurs, the warranty will be voided.

2.3 PRODUCT HAZARDS

 WARNING	Disconnect Power: Turn off power at distribution panel before beginning installation to protect installer from electrical hazards.
 CAUTION	Voltage and Current Compatibility: Confirm that the power source is compatible with the maximum voltage and current ratings of its product variant. Failure to do so could result in damage or fire.

3 PRODUCT DESCRIPTION

The Kobelt 7174 Rudder Feedback Unit (RFU) can be configured to have up to four potentiometers and two rudder end stop switches per side. It can be used as an input to Full Follow Up (FFU) electronic steering systems, autopilots, and rudder angle indicators. Movement of the rudder adjusts the internal potentiometer(s). The 7174 Rudder Feedback Unit can be used for steering applications, other marine applications, or industrial installations. The 7174 is designed for indoor and outdoor installation with a robust die cast bronze and stainless-steel construction to provide a long service life in a harsh marine and salt-water exposed environment.

3.1 TECHNICAL SPECIFICATIONS

Table 1: 7174 Technical Data – Standard Variants

MODEL		7174		
KOBELT PART #		7174-A	7174-B	7174-G
POTENTIOMETER		1k Ω	2x 1k Ω	-
MAX. POTENTIOMETER POWER		1 W		-
POTENTIOMETER CONNECTIONS		1x 3C/18 AWG Pigtail	2x 3C/18 AWG Pigtail	-
SWITCH CONTACTS		2x SPDT, Normally Closed (NC)	2x SPDT, Normally Closed (NC)	4x SPDT, Normally Closed (NC)
MAXIMUM SWITCH VOLTAGE		250VAC/24VDC		
MAXIMUM SWITCH CURRENT ¹	12 VDC	6 A		
	24 VDC	5 A		
	250 VAC	6 A		
MICROSWITCH CONNECTION		1x 4C/18 Pigtail	1x 8C/18AWG Pigtail	
OPERATING TEMPERATURE		-25°C to 70°C [-13°F to 158°F]		
PRODUCT WEIGHT		2.9 kg [6.5 lbs]		
SURFACE FINISH		Plain Bronze		

¹Maximum reported current is for an inductive load. Current is per switch contact.

Technical data and specifications are also available from our datasheet posted on www.kobelt.com or the technical drawings in [Appendix A](#).

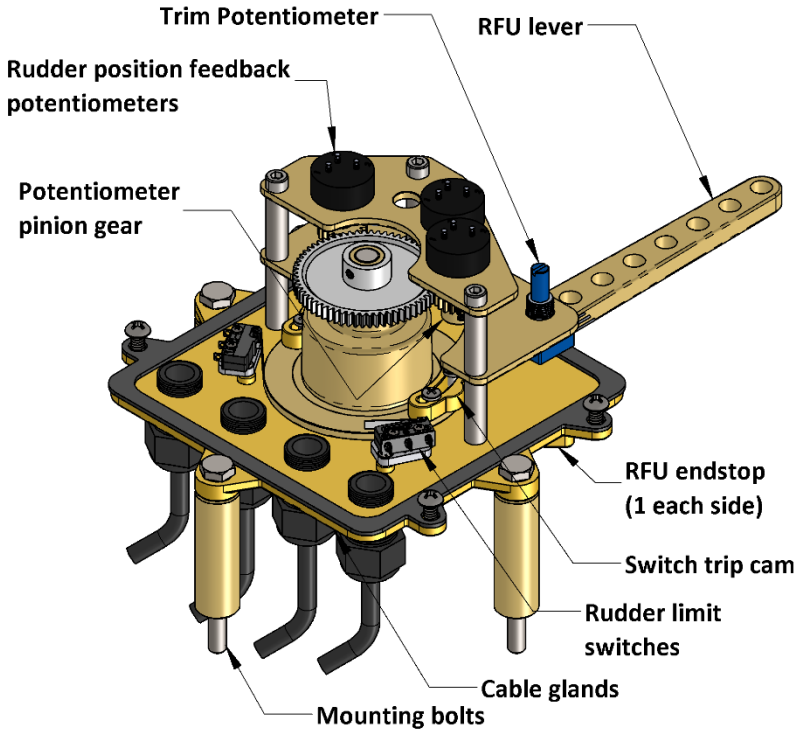

Note: Device shown with cover removed.

Figure 1: Product overview, 7174-CE shown

3.2 MODEL CODE KEY

7174- ← (list in alphabetical order)

Output Options

- A = potentiometer + 2 switches
- B = 2x potentiometers + 2 switches
- C = 3x potentiometers + 2 switches
- D = 1 trimpot
- E = 2 trimpots
- F = 3 trimpots
- G = 4 switches (2 sets)
- P = 1 potentiometer

Potentiometer Rating

- (blank) = 1 kohm
- H = 5 kohms

4 INSTALLATION

4.1 RECEIPT

Kobelt offers the 7174 rudder feedback unit in several configurations (reference [section 3.2](#)). Upon receipt of the device ensure that the model number and serial number are noted on the table in page 2 of this manual. The serial number can be found in the location noted at right. This model number will determine what spare parts are applicable.

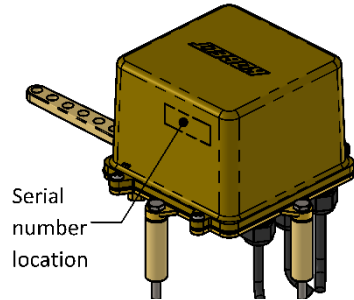

Figure 2: Part Identification

4.2 MECHANICAL

Ideally, the Rudder Feedback Unit should be mounted as close as possible to the tiller arm. Excessive lengths of connecting rods will lead to flexing and inaccuracies in the reported rudder position.

CAUTION

Minimize the connecting rod length to minimize errors in reported rudder position.

The Rudder Feedback Unit is equipped with (3) three ¼ UNC screws installed through the top surface for direct mounting. Reference the general arrangement drawing in [Appendix A](#) for the bolt pattern.

4.2.1 Mechanical Linkage

The RFU lever is provided with seven 5/16" [8mm] diameter holes on a 5/8" [16 mm] pitch. Select the outer most hole on the RFU lever possible to minimize errors arising from backlash. Locate the connecting rod position on the tiller arm to ensure that rudder stop limit switches trip without crashing into the RFU end stops (+/-44°). Follow the table below to ensure that the gearing between rudder movement and RFU are synchronized:

Table 2: RFU / tiller synchronization

7174		
Rudder Movement (H.O. to H.O.) (deg)	Travel Ratio	Dimension 'R' in [mm]
70	1.16:1	9.04 [230]
74	1.11:1	8.62 [219]
80	1.04:1	8.07 [205]
84	1.00:1	7.75 [197]
90	0.95:1	7.33 [186]
94	0.91:1	7.09 [180]

When installing the RFU remember to follow these tips:

- Ensure 90° relationships between the tiller arm, RFU lever and connecting link are maintained with the rudder in mid-ships position during alignment of all mechanical components.
- Ensure rudder feedback arm and rudder stock clamp swing equally on each side of mid-ships position.
- Locate 7174 Rudder Feedback Unit near rudder stock on a level surface.
- The threaded connection rod may need to be adjusted to achieve the correct mounting geometry.

Reference Figure 3 for clarification.

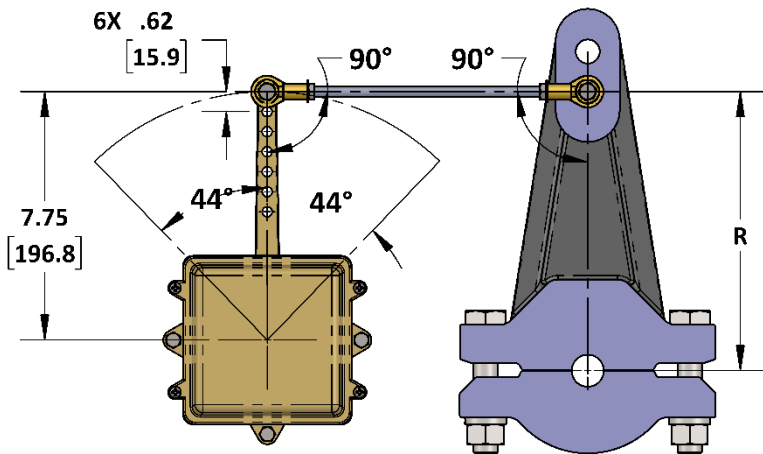

Figure 3: RFU Installation

Note: Connection kits are available from Kobelt (P/N: 7174-010X).

4.3 ELECTRICAL

When making the electrical connections, locate the electrical junction box;

- Within 6 feet [1.8 m] of the rudder feedback unit.
- Placed to protect external electrical cable from damage.

The cable gland locations are located on the bottom of the unit and are shown in Figure 1.

The internal potentiometer wire connections are shown in Figure 4. Figure 5 - Figure 7 depict the wiring assignment by color for various two limit switch models. Identify your specific configuration and refer to the appropriate diagram. Four limit switch configurations are shown in Figure 8.

The operating direction of the Potentiometer in relation to the Rudder Feedback Unit handle is shown in Figure 5 - Figure 8.

The product's 3C/18AWG electrical cable contains the following wires and related functions:

Table 3: 7174 Wire Connections

7174				
Wire #	Wire Name	Colour	Gauge	Function
1	POT+	White	18AWG	FFU potentiometer power supply connection.
2	POT WIPER	Red	18AWG	FFU potentiometer signal connection.
3	POT-	Black	18AWG	FFU potentiometer ground connection.

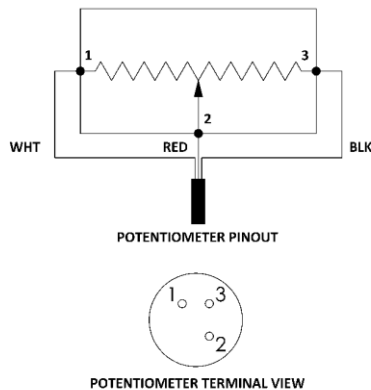

Figure 4: 7174 Potentiometer Wiring Diagram

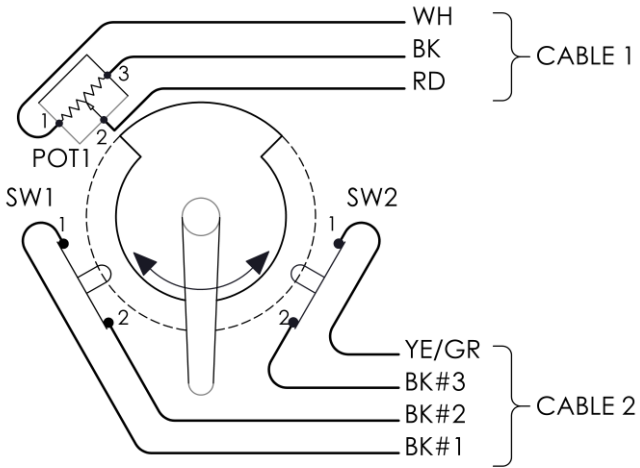

Figure 5: 7174-A Wiring

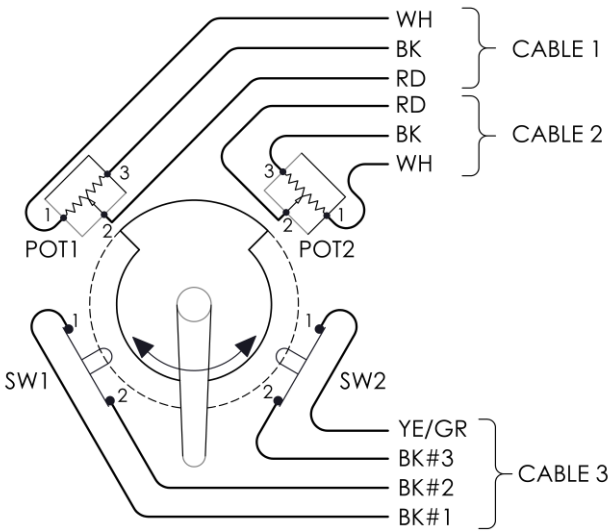

Figure 6: 7174-B Wiring

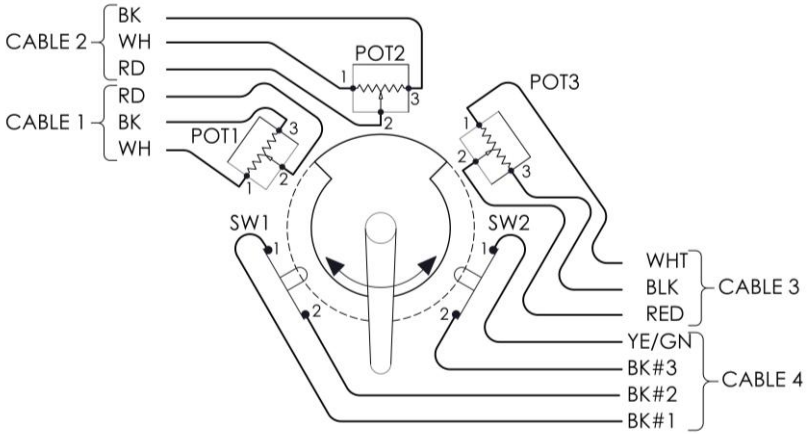

Figure 7: 7174-C Wiring

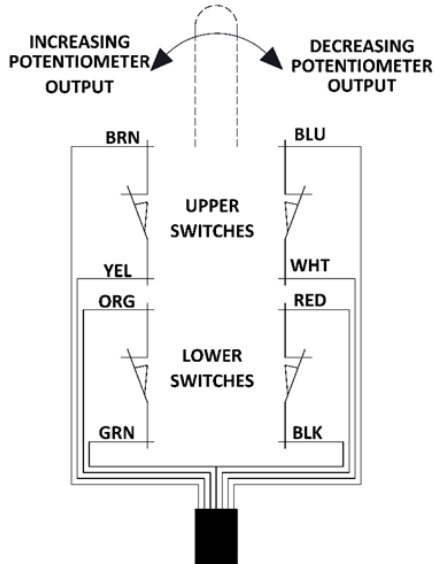

Figure 8: 7174-G Internal Wiring

NOTICE When wiring the rudder end stop switches directly to the steering solenoid valves, it is recommended to place a 1N4007 protection diode across the coil terminals.

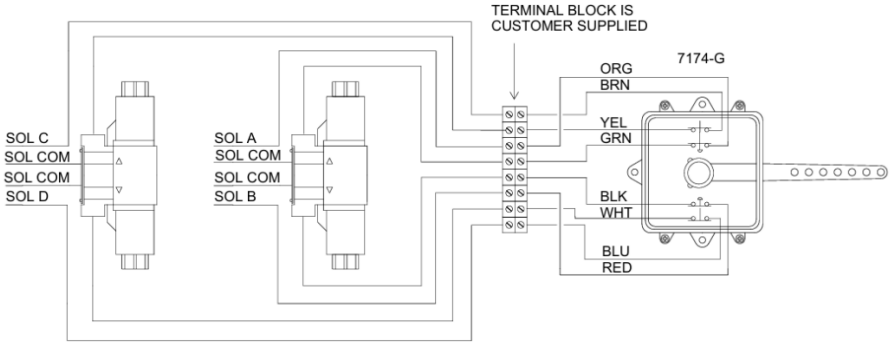

Figure 9: 7174-G Limit Switch Wiring Diagram

WARNING Failure to use a TVS diode when switching solenoid coils will reduce the life of the rudder end stop switches.

5 COMMISSIONING

5.1 ELECTRICAL CHECK



CAUTION

Ensure that the rear cover is installed and secured before powering on the 7174.

- Confirm that the electrical connections to the 7174 have been made.
- Confirm that port and starboard rudder movements are displayed correctly at the rudder angle indicators.
- Confirm that the rudder range of motion is reported correctly to the rudder angle indicators and steering controller.
- Ensure that the rudder end stop switches trip before the rudder or RFU lever impacts the rudder stops. See [section 6.2.1](#) for adjusting.



CAUTION

The Functional Test should be carried out while the vessel is still at dock and before it is taken out to sea after installation has been completed.

6 MAINTENANCE

6.1 PREVENTATIVE MAINTENANCE

- Quarterly (4 times/year)
 - Visually inspect wire and cable insulation for splits or damage.
 - Ensure there is no visible corrosion on the unit.
 - Confirm that the rudder angle indicators indicate zero degrees when the rudder is centered.
- Every (2) two years
 - Confirm all electrical screw terminals are secured.
 - Confirm cable glands are secured to cables.

6.2 SERVICE

6.2.1 Rudder End-stop Switches

To adjust the rudder end-stop trip position follow these instructions:

1. Position the rudder to the desired trip position.
2. Remove the RFU cover.
3. Locate the relevant switch trip cam (See Figure 1).
4. Loosen the two screws and rotate the cam until the switch just trips and secure the two screws.
5. Repeat for the other switch.

6.2.2 Potentiometer Centering

When replacing the potentiometer or if the setting has become disturbed, follow these steps to center the output:

1. Position the rudder in the center (dead ahead) position.
2. Remove the RFU cover.
3. Locate the potentiometer in need of centering (See Figure 1).
4. Connect a multimeter to the Pot – (white wire) and the Pot Wiper (green wire). Set the meter to read resistance.
5. Loosen the two locking set screws on the pinion gear with a 1/16-inch Allen key.
6. Using a short flat head screwdriver, rotate the potentiometer shaft until the meter reads half of the rated output (500 ohms for a 1K potentiometer).
7. Tighten the two locking set screws and replace the cover.

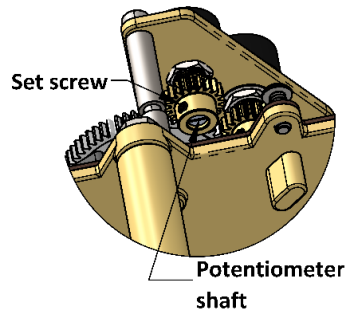

6.3 RECOMMENDED SPARE PARTS

Depending on the severity and criticality of service, it may be necessary to keep spare potentiometers on hand.

When purchasing replacement parts refer to Appendix B: Parts List at the back of this manual for Kobelt component Part Numbers.

NOTICE

It is recommended that any required service work on a Kobelt product be performed by a factory authorized service representative. Please contact the nearest Kobelt authorized distributor for assistance.

7 TROUBLESHOOTING

If you encounter problems with the operation of your product, please refer to the troubleshooting suggestions before contacting Kobelt for assistance. If the steps below do not resolve your issue, please reach out either Kobelt directly or our Dealers in your area.

Table 4: Common Solutions

Problem (Issue encountered)	Cause (What it means)	Corrective Action (What to do)
Rudder Feedback Unit action is reversed.	Wiring is backwards.	Swap the POT+ and POT- output wires to their respective system connections.
Rudder Feedback Unit does not move rudder at all.	The rest of the system isn't hooked up correctly.	<ol style="list-style-type: none"> 1. Check system wiring. 2. Confirm wiring to Rudder Feedback Unit.
	Broken potentiometer or contact.	<ol style="list-style-type: none"> 1. Use a multi-meter to monitor the resistance of the wiring between potentiometer contacts. 2. Check for normal operation of the potentiometer by measuring the connection while moving the Rudder Feedback Unit. 3. Check potentiometer directions. 4. Replace any damaged potentiometers.
	Wiring is wrong.	Check wiring against User Manual wiring diagrams for Feedback Unit and connected Products.

8 REVISION HISTORY

Table 5: Table of revision changes

Document Revision	Release Date	ECN	Author	Revision Summary
E	2024-01-22	00950	SV	<ul style="list-style-type: none"> Changed the wire in potentiometer to shielded type (from Green to Red) Table 3, Fig 4, 5, 6 and 7, Cable part number changed from (6014-0001 to 6525W-CT-RL) Table 6, 7 and 8
F	2024-08-15	01066	HE	<ul style="list-style-type: none"> Pot 3, terminals 2 & 3 wire colors swapped
G	2024-10-23	01100	SV	<ul style="list-style-type: none"> Corrected the Part List Note on P22, P25 and P28 Changed cable gland part number in the 7174-BG BOM, P30
H	2026-04-10	01439	GG	<ul style="list-style-type: none"> Section 3.1 Technical specification: Updated microswitch voltage, current rating. Add -G configuration. Added normally closed(N.C) identifier to switch contact description. Section 4.3 Electrical: Added limit switch wiring details Moved Revision history to before warranty. Appendix B: Updated parts lists to call for microswitch repair kits. Added in microswitch washer and changed mounting screw. Appendix D: Made changes to incorporate 7174-RK-01 & 7174-RK-02 microswitch repair kits.

9 WARRANTY

Kobel Manufacturing Co. Ltd. ("Kobel") warrants the Products and Parts manufactured by Kobel to be free from defects in workmanship or material and that said products are designed mechanically and functionally to perform to specifications.

This warranty is effective providing:

- The equipment is used within the intended operating conditions and in accordance with Kobel recommendations.
- The equipment is installed according to equipment diagrams, specifications, and recommendations which Kobel has provided.

This warranty becomes invalid if the factory supplied serial number has been removed or altered on the product. This warranty does not cover cosmetic damage or damage caused by an act of God, accident, misuse, abuse, negligence, or modification of any part of the product. This warranty does not cover damage due to improper operation or maintenance, connection to inappropriate equipment or attempted repair by anyone other than an authorized Kobel representative.

Upon identification of a potential issue or defect with a Kobel Product or Part, the Warranty Applicant ("Applicant") must immediately contact Kobel and describe the issue in writing, by letter, fax, email, or other electronic conveyance. Kobel will then assess the cause of the defect and determine warranty applicability and appropriate remediation.

If any part is found to be defective, Kobel will replace said part FOB the Kobel factory provided that any such defective part is returned by the Buyer with freight and applicable forwarding charges prepaid by the Buyer. Kobel's sole obligation to the Applicant will be to repair or replace the defective part with same or similar product, to a maximum value of the list price of the product or part. The Kobel warranty does not cover labour charges, travel or any other associated expenses.

All Products and Parts manufactured by Kobel, are subject to a warranty against manufacturer's defects in materials or workmanship for a period of two (2) years from the date of purchase.

Kobel will be responsible for all Products or Parts sold by Kobel but manufactured by 3rd party manufacturing companies. However, these products and parts are subject to applicable 3rd party warranties and may not be the same as the Kobel warranty.

10 APPENDIX A: INSTALLATION DIMENSIONS

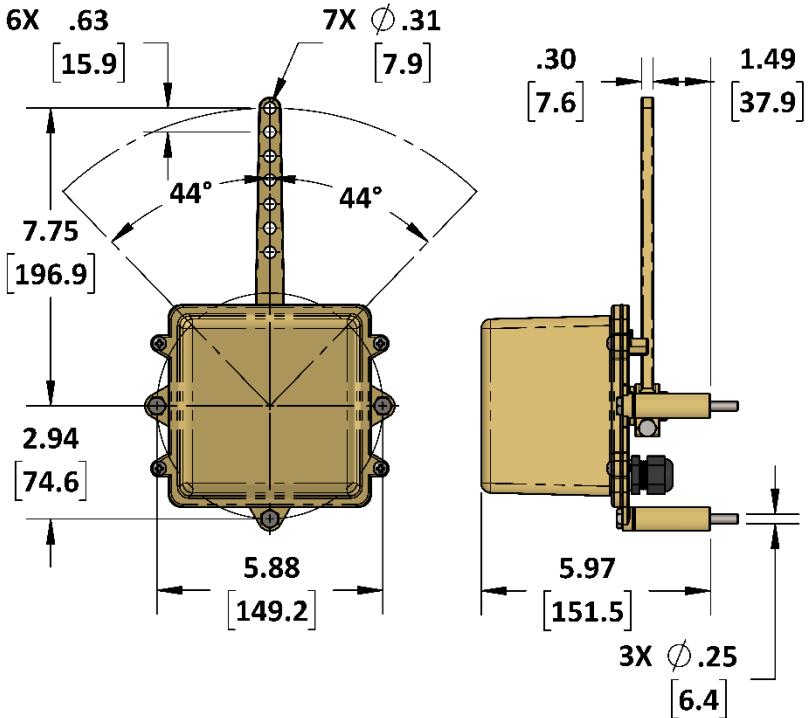

11 APPENDIX B: PARTS LIST

7174-AD

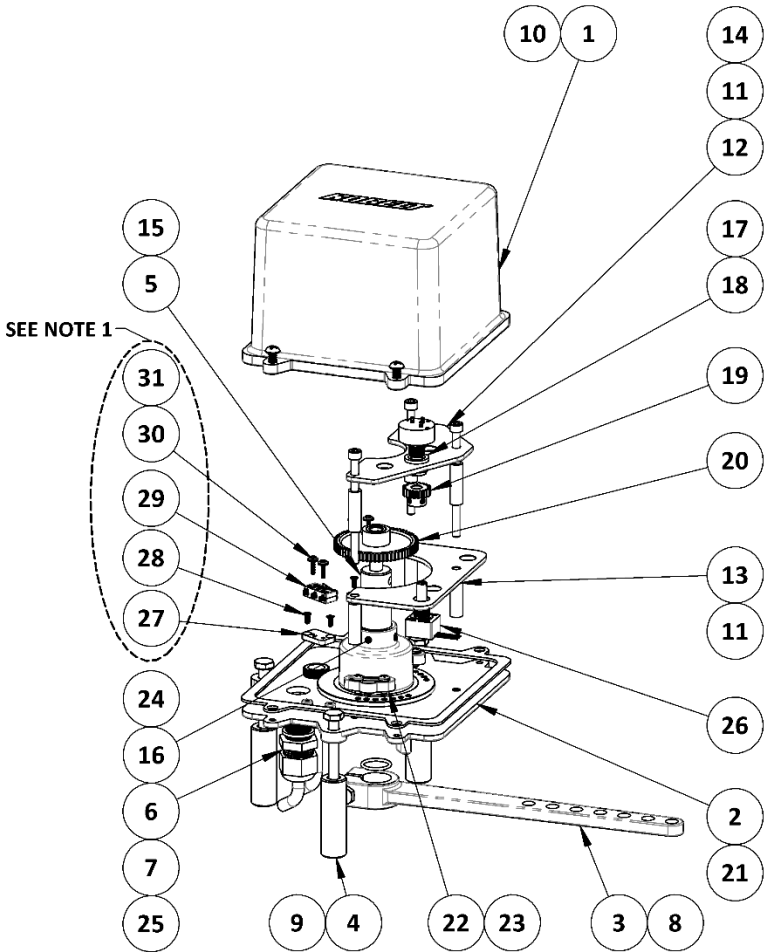

Figure 9: 7174-AD Parts Diagram

Table 6: BOM for 7174-AD

ITEM	QTY.	PART NUMBER	DESCRIPTION	NOTES
1	1	7174-0001	HOUSING	-
2	1	7174-0002	COVER; RUDDER FEED BACK UNIT	-
3	1	7174-0003	LEVER; RUDDER FEEDBACK UNIT	-
4	3	7174-0009	SPACER, BRASS	-
5	1	7174-0010	SHAFT	-
6	2	6001-0248	CABLE GLAND; M16 X 1.5, .197-.394 CABLE, PA6, BLACK	-
7	2	6001-0248-W-M16	WASHER, SEALING, M16, POLYETHYLENE	-
8	1	1001-1020	SCREW - HEX HD; 1/4-20 X 1-1/4, 18-8	-
9	3	1001-1048	1/4-20 X 3.0, HEX HD. CAPSCREW, SS	-
10	4	1010-0808	SCREW, RND HD PHIL, #10-24 X 1/2, 18-8 SS	-
11	6	7174-0008	SPACER, 7172, 1.04IN LG	-
12	1	7174-0007	POT BRACKET	-
13	1	7174-0006	BRACKET; RUDDER FEEDBACK UNIT	-
14	3	1002-0844	CAP SCREW - SKT HD; #10-24 X 2-3/4 LG, 18-8	-
15	1	1101-0016	O-RING, 3/4 X 5/8 X 1/16, NBR70	-
16	1	7174-0004	CAM PLATE	-
17	1	POT-1	POTENTIOMETER, 1K, 1TURN, 340 DEG, 22MM DIA	-
18	1	6639-0001	SHIM WASHER, 10MM X 2MM, AISI 304	-
19	1	Y-3220	SPUR GEAR - BRASS; 32P/20T/B STYLE/.250IN BORE + 2 SET SCREWS	-
20	1	YPB-3264	SPUR GEAR 64T DERLIN W/ 5/16 BRASS INSERT	-
21	1	7174-0027	GASKET	-
22	2	7174-0005	CAM, SWITCH TRIP	-
23	4	1012-0606	SCREW, PAN HD, PHL DRIVE, 6-32 x 3/8IN, 18-8 SS	-
24	1	1024-0816	PIN, .1875 DIAMETER	-
25	1	6525W-CT-RL	CABLE; 3C/18AWG / SHLD / 600V / 105C / GRY	-

26	1	TRIMPOT-1	POTENTIOMETER, TRIM, 10K, SINGLE TURN, 5/8 X 11/16 RECT	-
27	2	7174-0014	BRACKET, MICROSWITCH, 7174	1
28	5	1009-0304	SCREW, FLAT HD, PHP DR, 3-48 X 1/4, 18-8	1
29	1	7174-RK-01	REPAIR KIT; MICROSWITCHES; RFU W/ 2 SWITCHES	1
30	4	1012-3210	SCREW, PAN HD, PHP DR, M2-0.4; 10MM LG; 18- 8	1
31	4	1023-0102	WASHER; FLAT; #2 X 1/4OD; 18-8	1

7174-B

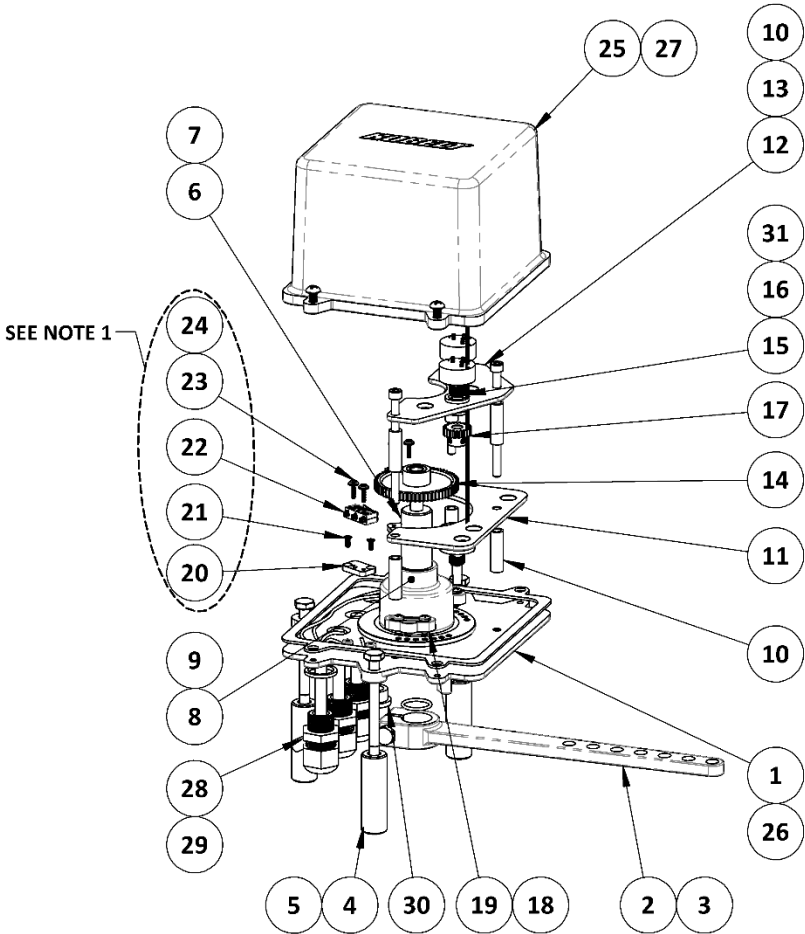

Figure 10: 7174-B parts list

Table 7: BOM for 7174-B

ITEM	QTY.	PART NUMBER	DESCRIPTION	NOTES
1	1	7174-0002-4	COVER; RUDDER FEED BACK UNIT; 4 HOLES	-
2	1	7174-0003	LEVER; RUDDER FEEDBACK UNIT	-
3	1	1001-1020	SCREW - HEX HD; 1/4-20 X 1-1/4, 18-8	-
4	3	7174-0009	SPACER, BRASS	-
5	3	1001-1048	1/4-20 X 3.0, HEX HD. CAPSCREW, 18-8	-
6	1	7174-0010	SHAFT, 7174 RFU	-
7	1	1101-0016	O-RING; 3/4 X 5/8 X 1/16 / NBR70	-
8	1	7174-0004	CAM PLATE	-
9	1	1024-0816	PIN; SLOTTED SPRING; 3/16 DIA X 1LG; AISI 304	-
10	6	7174-0008	SPACER, 7172, 1.04IN LG	-
11	1	7174-0006	BRACKET; RUDDER FEEDBACK UNIT	-
12	1	7174-0007	POT BRACKET	-
13	3	1002-0844	SCREW, SKT HD CAP; 10-24 X 2-3/4 LG, 18-8	-
14	1	YPB-3264	SPUR GEAR 64T DERLIN W/ 5/16 BRASS INSERT	-
15	2	POT-1	POTENTIOMETER, 1K, 1TURN, 340 DEG, 22MM DIA	-
16	2	6639-0001	SHIM WASHER, 10MM X 2MM, AISI 304	-
17	2	Y-3220	SPUR GEAR - BRASS; 32P/20T/B STYLE/.250IN BORE + 2 SET SCREWS	-
18	4	1012-0606	SCREW, PAN HD, PHL DRIVE, 6-32 x 3/8IN, 18-8 SS	-
19	2	7174-0005	CAM, SWITCH TRIP	-
20	2	7174-0014	BRACKET, MICROSWITCH, 7174	1
21	4	1009-0304	SCREW, FLAT HD, PHP DR, 3-48 X 1/4, 18-8	1
22	1	7174-RK-01	REPAIR KIT; MICROSWITCHES; RFU W/ 2 SWITCHES	1
23	4	1012-3210	SCREW; PAN HEAD; PHP DR; M2X.4; 10MM LG; 18-8	1
24	4	1023-0102	WASHER; FLAT; #2 X 1/4 OD; 18-8	1

25	1	7174-0001	HOUSING	-
26	1	7174-0027	GASKET, 7174 HOUSING, NBR	-
27	4	1010-0808	SCREW, RND HD PHIL, #10-24 X 1/2, 18-8 SS	-
28	3	6001-0248	CABLE GLAND; M16 X 1.5, .197-.394 CABLE, PA6, BLACK	-
29	3	6001-0248-W-M16	WASHER, SEALING, M16, POLYETHYLENE	-
30	1	6001-0311	PLUG - CABLE GLAND; M16 X 1.5/ IP68 / BLACK	-
31	4	6525W-CT-RL	CABLE; 3C/18AWG / SHLD / 600V / 105C / GRY	-

7174-BG

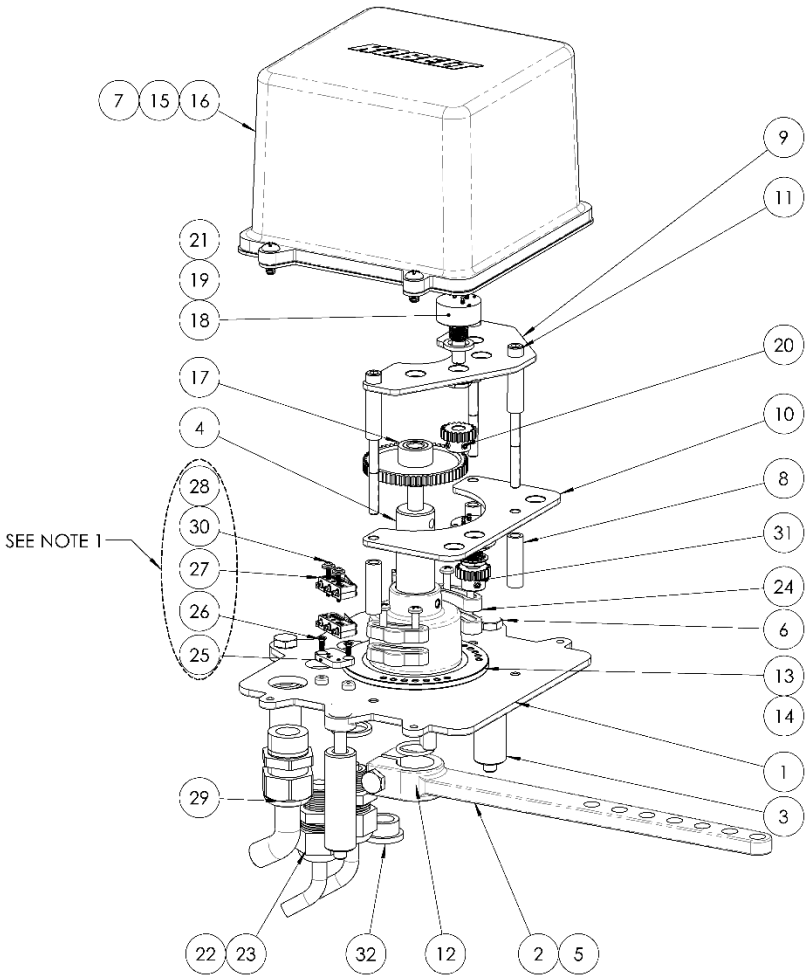

Figure 11: 7174-BG parts list

Table 8: 7174-BG BOM

ITEM	QTY.	PART NUMBER	DESCRIPTION	NOTES
1	1	7174-0002-3	COVER; RUDDER FEED BACK UNIT; 4 HOLES (BG-CG)	-
2	1	7174-0003	LEVER; RUDDER FEEDBACK UNIT	-
3	3	7174-0009	SPACER, BRASS	-
4	1	7174-0010	SHAFT, 7174 RFU	-
5	1	1001-1020	SCREW - HEX HD; 1/4-20 X 1-1/4, 18-8	-
6	3	1001-1048	1/4-20 X 3.0, HEX HD. CAPSCREW, 18-8	-
7	4	1010-0808	SCREW, RND HD PHIL, #10-24 X 1/2, 18-8 SS	-
8	6	7174-0008	SPACER, 7172, 1.04IN LG	-
9	1	7174-0007	POT BRACKET	-
10	1	7174-0006	BRACKET; RUDDER FEEDBACK UNIT	-
11	3	1002-0844	SCREW, SKT HD CAP; 10-24 X 2-3/4 LG, 18-8	-
12	1	1101-0016	O-RING; 3/4 X 5/8 X 1/16 / NBR70	-
13	1	7174-0004	CAM PLATE	-
14	1	1024-0816	PIN; SLOTTED SPRING; 3/16 DIA X 1LG; AISI 304	-
15	1	7174-0027	GASKET, 7174 HOUSING, NBR	-
16	1	7174-0001	HOUSING	-
17	1	YPB-3264	SPUR GEAR 64T DERLIN W/ 5/16 BRASS INSERT	-
18	2	POT-1	POTENTIOMETER, 1K, 1TURN, 340 DEG, 22MM DIA	-
19	2	6639-0001	SHIM WASHER, 10MM X 2MM, AISI 304	-
20	2	Y-3220	SPUR GEAR - BRASS; 32P/20T/B STYLE/.250IN BORE + 2 SET SCREWS	-
21	4	6525W-CT-RL	CABLE; 3C/18AWG / SHLD / 600V / 105C / GRN	-
22	2	6001-0248-W-M16	WASHER, SEALING, M16, POLYETHYLENE	-
23	2	6001-0248	CABLE GLAND; M16 X 1.5, .197-.394 CABLE, PA6, BLACK	-

24	4	7174-0005	CAM, SWITCH TRIP	-
25	2	7174-0014	BRACKET, MICROSWITCH, 7174	1
26	4	1009-0304	SCREW, FLAT HD, PHP DR, 3-48 X 1/4, 18-8	1
27	1	7174-RK-02	REPAIR KIT; MICROSWITCHES; RFU W/ 4 SWITCHES	1
28	4	1023-0102	WASHER; FLAT; #2 X 1/4 OD; 18-8	1
29	1	6001-0277	CABLE GLAND, 1/2 NPT, 0.354-0.630 IN , POLYAMIDE	-
30	4	1012-3216	SCREW, PAN HEAD PHL, M2X0.4 X 16MM LG, 18-8	1
31	4	1012-0610	MACHINE SCREW - PAN HD PHILLIPS; #6 UNC X 5/8 LG, 18-8	-
32	1	6001-0311	PLUG - CABLE GLAND; M16 X 1.5/ IP68 / BLACK	-

11.1 PARTS LIST NOTES:

1. Contained in microswitch retrofit kits: 7174-RF-01 or 7174-RF-02. See section 12.1 and section 12.2 to determine if a retrofit kit is required or can purchase standalone part, and which microswitch kit is required.

12 APPENDIX C: DETERMINING RFU GENERATION AND REQUIRED RETROFITS

12.1 DETERMINATION OF MICROSWITCH GENERATION

In mid 2023, rudder limit microswitches in the 7174 RFUs were replaced with a new style of microswitch. The newer generation microswitch requires a mounting bracket and different hardware for its implementation. Customers with RFUs purchased prior to this change will require a retrofit kit if they are replacing the microswitch. The old style microswitch was Kobelt PN: 6001-0104 and is a bare plunger style microswitch. The new microswitch, Kobelt PN: 6001-0112, is a plunger style but with an actuation lever.

Determining what generation of microswitch is currently installed in your unit can be done by physically examining the microswitch and comparing to those shown in Table 5. If the RFU contains generation 1 microswitches and a replacement is required, it will be necessary to purchase a retrofit kit, Kobelt PN: 7174-RF-XX. Determination of which kit is required is outlined in section 12.2. Each retrofit kit contains the switches and mounting components for one side of the RFU. If all microswitches are to be replaced, it will be required to order two retrofit kits.

Table 5: Microswitch determination

Key Features	Generation 1	Generation 2
Micro Switch part number	6001-0104	6001-0112
Picture		
Replacement part number	Retrofit kit, 7174-RF-XX* *See Table 6 to determine the retrofit kit required	Microswitch only, 6001-0112



12.2 DETERMINATION OF REQUIRED RETROFIT KIT

There are two retrofit kits available, one for RFUs with two micro switches, and another for RFUs with four microswitches. Determination of which kit is required can be done by physically examining the microswitch arrangement in your unit and comparing to the arrangements shown in Table 6. Alternatively, if the model number of your unit is known, it can be cross referenced to section 3.2 to determine the amount of microswitches present in your RFU.

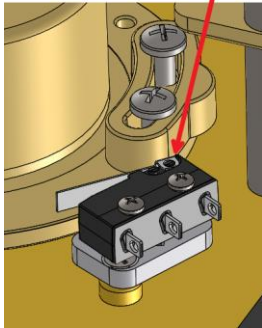
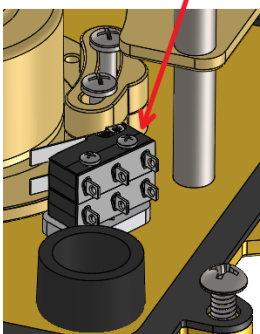
Table 6: Determination of required retrofit kit

Key Features	Two microswitch RFU	Four microswitch RFU
Picture	<p>One microswitch per side</p> 	<p>Two microswitches per side</p> 
Required retrofit kit part No.	7174-RF-01, one required per RFU.	7174-RF-02, one required per RFU.

13 APPENDIX D: INSTALLING MICROSWITCH RETROFIT KIT

 WARNING	Disconnect Power: Turn off power at the distribution panel and lockout before servicing the microswitches
 WARNING	Replacing microswitches should be done by Kobelt factory authorized service representatives. Failure to do so result in improper installation and failure of the microswitch.

Refer to section 13.1 or 13.2 depending on if you are replacing a two switch RFU or four switch RFU, respectively. The instruction can be followed whether retrofitting or replacing generation 2 microswitches. If the generation 2 microswitches are just being replaced with new ones, ignore steps relating to removing the microswitch bracket.

13.1 7174-RF-01 / 7174-RK-01 – Two Switch RFUs

 WARNING	Replacing microswitches should be done by Kobelt factory authorized service representatives. Failure to do so result in improper installation and failure of the microswitch.
NOTICE	Please read through and review steps and all figures in section 13.1 before starting the removal of the old microswitches and installation of the new microswitch.

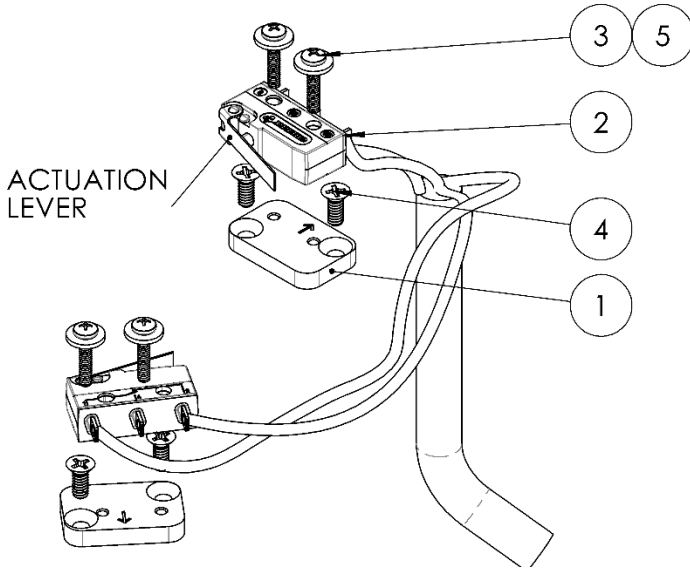

Figure 12: Microswitch retrofit kit, 7174-RF-01

Table 7: 7174-RF-01 BOM

7174-RF-01 BOM			
Item	Qty	Part Number	Description
1	2	7174-0014	BRACKET, MICROSWITCH, 7174
2	1	7174-RK-01	REPAIR KIT; MICROSWITCHES; RFU W/ 2 SWITCHES
3	4	1012-3210	SCREW, PAN HD, PHP DR, M2-0.4 X 10, 18-8
4	4	1009-0304	SCREW, FLAT HD, PHP DR, 3-48 X 1/4, 18-8
5	4	1023-0102	WASHER; FLAT; #2 X 1/4 OD; 18-8

1. Note connections of all wires going to the old microswitches prior to disconnecting. It is recommended to fill out the colors of wire going to each terminal on the diagram shown in Figure 13. On the old microswitch, Kobelt PN 6001-0104, the terminals are labelled 1 and 2 and correspond to terminals 1 and 2 on the new microswitches.

IMPORTANT: Two switch RFUs come from the factory with a four-cable conductor that contains three black wires and one green with yellow stripe. When noting the black wires, be sure include the number printed on the wire casing.

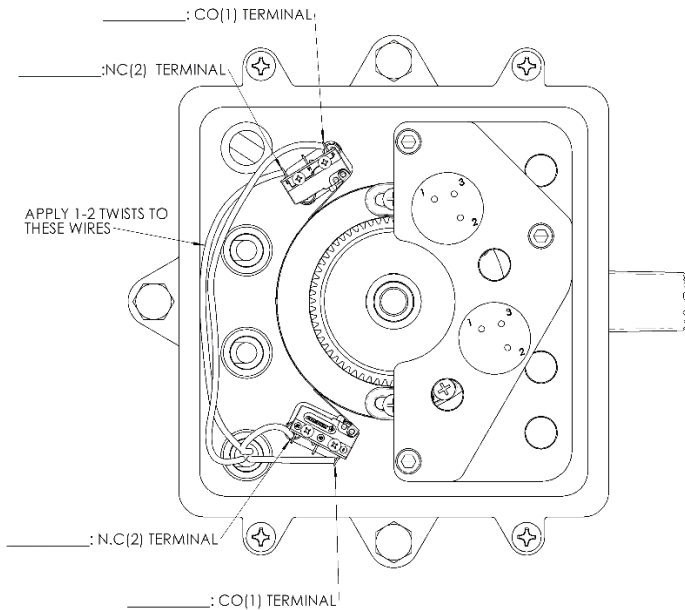

Figure 13: Wiring schematic for customer fill out, two switch module

2. Remove and discard the old microswitches and cable.
3. Refer to Figure 14 and note the engraved arrow on the microswitch bracket ① is facing outwards on both sides of RFU.
4. Apply Loctite 243(Blue) to X2 Flat head screws ④.

-
5. Install bracket ① with screws ④ into the RFU cover plate, 7174-0002, ensuring the engraved arrow is correctly orientated.
 6. Refer to Figure 14 and note the orientation of the installed microswitch ② on each side of the RFU.
 7. Thread the new microswitch cable through the same gland as the hold cable. Do not tighten the cable gland.
 8. Place the microswitch ② on top of the bracket ① orientating the microswitch so the actuation lever is as shown in Figure 14. For reference, the actuation lever is pointed to in Figure 12.
 9. Apply Loctite 243(Blue) to X2 pan head screws ③.
 10. Use X2 screws ③ and washers ⑤ and tighten snug to secure the microswitch ② for positioning.

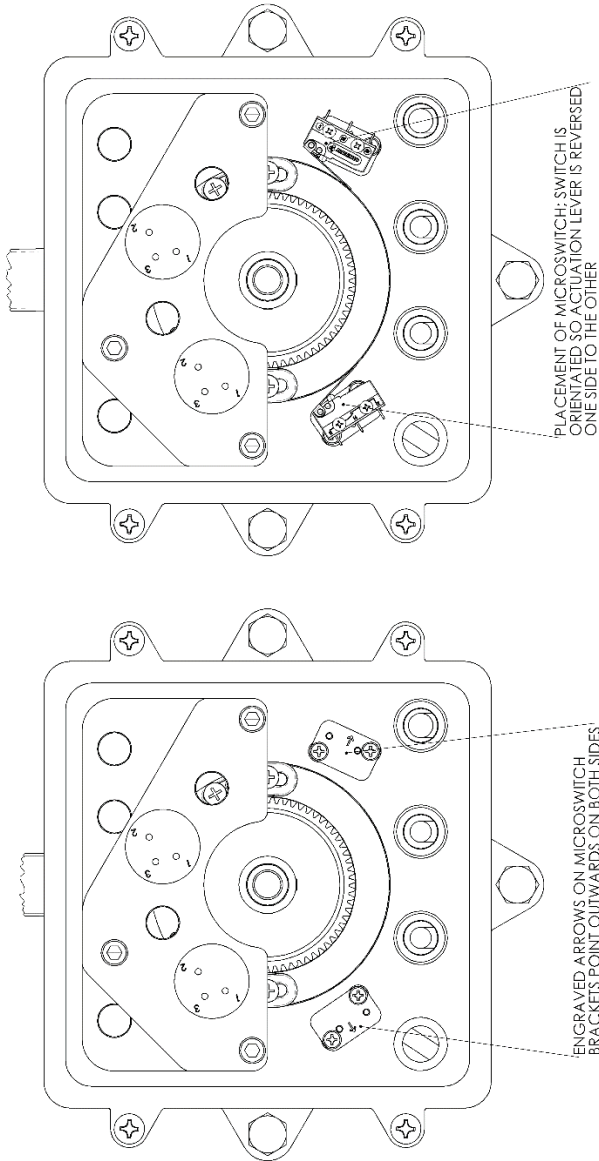

Figure 14: Placement of microswitch and microswitch bracket, 7174-B shown.

-
11. Review section 6.2.1 and set the switch trip cam(See Figure 1) in the correct position for the new microswitch.
 12. Check correct operation of the switch by rotating the RFU lever through its full travel, ensure:
 - a. The actuation lever of microswitch ② is clear of any obstructions through its range of motion.
 - b. The microswitch ② actuation lever is depressed enough to actuate the switch contacts when the RFU is at its limit:

This can be done by checking for no continuity across the Normally Closed(N.C) terminal 2 and the Common(C) terminal 1. See Figure 16 for clarity on terminals being checked. When the switch is depressed, terminal 1 and 2 should have no continuity.

When installed correctly, the microswitch ② lever should be approximately level with the side of the microswitch body.

- c. The microswitch ② lever is not over-actuated:

Refer to Figure 15, the microswitch lever should not be pushed past the horizontal position relative to the microswitch housing.
 - d. The microswitch ② lever is raised enough to open the switch the switch contacts when the RFU is off of its travel limit.

This can be done by checking for a closed circuit (continuity) across the Normally Closed and Common terminals. When the RFU lever is off its limit position, there should be continuity across terminal 1 and 2.

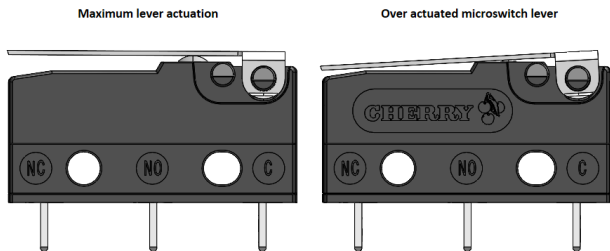

Figure 15: Maximum and over actuated microswitch lever.

If conditions 'a', 'b', 'c' or 'd' are not met, loosen the switch trip cam and adjust its position until the microswitch is actuated and allowed to reset in the desired positions. The microswitch can also be adjusted by loosening the screws ③ and moving the microswitch around.

13. When the microswitch position is determined to be correct, tighten the microswitch screws ③ to 0.85 lbs.in [0.1Nm]. The switch trip cam screws should be tightened secure.
14. The microswitches come wired as shown in Figure 16. Compare this to the wiring noted in the original switches that was noted in step 1. If there is any difference, make necessary adjustments at the junction box to ensure the same functionality of the microswitches. Do not de-solder the cable at the microswitch terminal and adjust conductor position.

NOTICE

Do no de-solder microswitch conductors. Soldering the microswitch leads requires special tooling and techniques to ensure the microswitches are not damaged. If you require microswitches wired in a different configuration than supplied in the microswitch kit, contact the Kobelt Factory for more information.

15. Route the microswitch cable:
 - a. Refer to Figure 16 for the recommended wire routing route to ensure the wiring are free of any moving parts.
 - b. Install cable ties to secure the switch conductors
 - i. Attach the cable ties as shown in Figure 16.
 - ii. Secure excess conductor length either to one of the other cables coming from a gland or with the included adhesive switch mount.
 - c. Tighten the cable gland to fully secure and seal the cable assembly.
16. Refer to section 5 for recommissioning the RFU once all the faulty switches have been replaced.

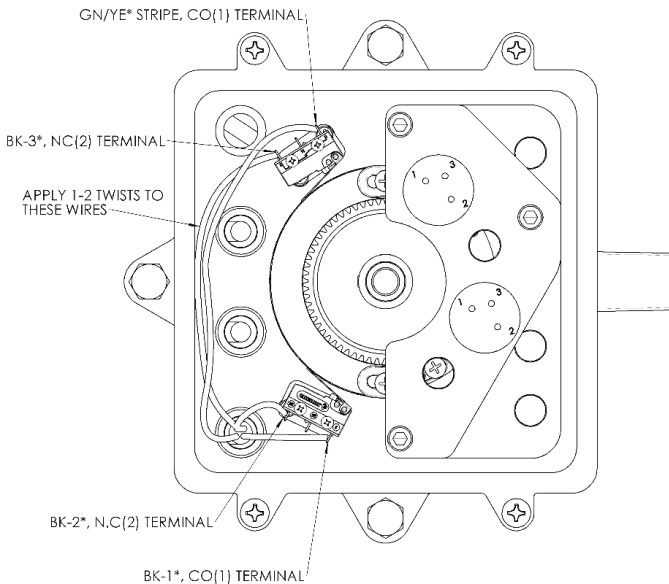

Figure 16: Default factory wiring diagram of new microswitches, 7174-B shown.

13.2 7174-RF-02 / 7174-RK-02 – FOUR SWITCH RFUS

⚠ WARNING	Replacing microswitches should be done by Kobelt factory authorized service representatives. Failure to do so result in improper installation and failure of the microswitch.
NOTICE	Please read through and review steps and all figures in section 13.2 before starting the removal of the old microswitch and installation of the new microswitch.

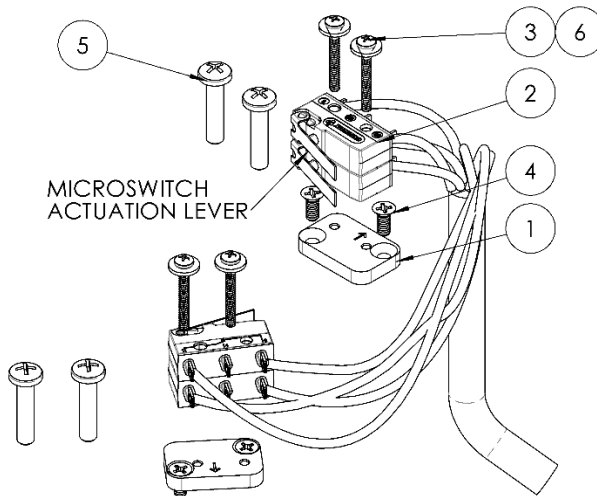

Figure 17: Microswitch retrofit kit, 7174-RF-02

Table 8: 7174-RF-02 BOM

7174-RF-02 BOM			
Item	Qty	Part Number	Description
1	2	7174-0014	BRACKET, MICROSWITCH, 7174
2	1	7174-RK-02	REPAIR KIT; MICROSWITCHES; RFU W/ 4 SWITCHES
3	4	1012-3216	SCREW, PAN HEAD PHL, M2X0.4 X 16MM LG, 18-8
4	4	1009-0304	SCREW, FLAT HD, PHP DR, 3-48 X 1/4, 18-8
5	4	1012-0610	MACHINE SCREW - PAN HD PHILLIPS; #6 UNC X 5/8 LG, 18-8
6	4	1023-0102	WASHER; FLAT; #2 X 1/4 OD; 18-8

1. Note connections of all wires going to the old microswitches prior to disconnecting by filling in the colors of wires in Figure 18. On the old microswitch, Kobelt PN 6001-0104, the terminals are labelled 1 and 2, and correspond to terminals 1 and 2 on the new microswitches.

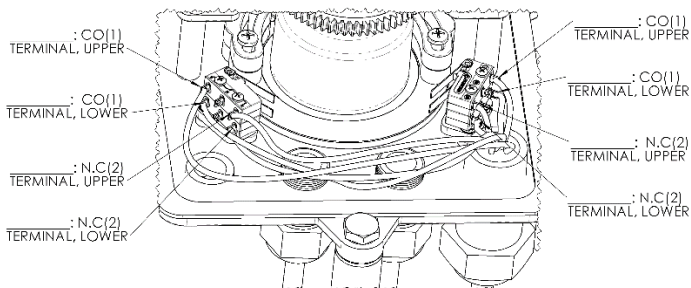

Figure 18: Wiring schematic for customer fill out, four switch module

2. Remove and discard the old microswitches and cable.
3. Refer to Figure 14 and note the engraved arrow on the microswitch bracket ① is facing outwards on both sides of RFU.
4. Apply Loctite 243(Blue) to X2 Flat head screws ④.
5. Install bracket ① with screws ④ into the RFU cover plate, 7174-0002, ensuring the engraved arrow is correctly orientated.
6. Refer to Figure 14 and note the orientation of the microswitch ② on both sides of the RFU.
7. Thread the new microswitch cable through the same gland as the old microswitch cable. Do not tighten the cable gland yet.
8. Place the microswitches ② on top of the bracket ① orientating the microswitches so the actuation lever is as shown in Figure 14. For reference, the actuation lever is pointed to in Figure 17.
9. Apply Loctite 243(Blue) to X2 pan head screws ③.
10. Use X2 screws ③ and 2X washer ⑥ for each microswitch and tighten snug onto the microswitches ②.

11. Review the old versus new arrangement of the switch trip cams shown in Figure 19.
12. Remove the upper switch trip cams.
13. Discard the old switch trip cam screws and spacers.
14. Apply Loctite 243(Blue) to the shorter screws ⑤ included in the retrofit kit.
15. Replace the upper switch trip cam and secure with the shorter screws ⑤, leaving out the spacer.

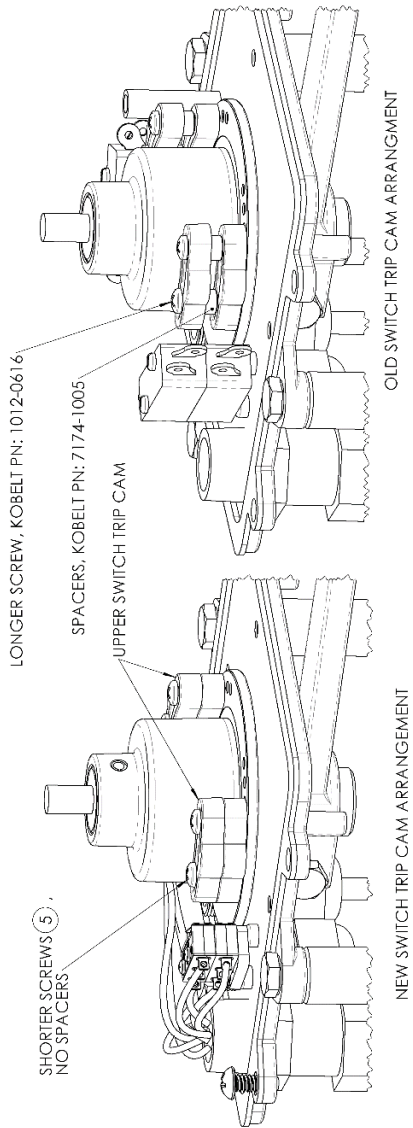

Figure 19: Arrangement of switch trip cams old microswitch and new microswitch

16. Review section 6.2.1 and set the switch trip cam in the correct position for the new microswitch.
17. Check correct operation of the switches by rotating the RFU lever through its full travel, ensure:
 - a. The actuation lever of microswitch ② is clear of any obstructions through its range of motion.
 - b. The microswitch ② actuation lever is depressed enough to actuate the switch contacts when the RFU is at its limit:

This can be done by checking for no continuity across the Normally Closed(N.C) terminal 2 and the Common(C) terminal 1. See Figure 20 for clarity on terminals being checked. When the switch is depressed, terminal 1 and 2 should have no continuity.

When installed correctly, the microswitch ② lever should be approximately level with the side of the microswitch body.

- c. The microswitch ② lever is not over-actuated:

Refer to Figure 15, the microswitch lever should not be pushed past the horizontal position relative to the microswitch housing.
- d. The microswitch ② lever is raised enough to open the switch the switch contacts when the RFU is off of its travel limit.

This can be done by checking for a closed circuit (continuity) across the Normally Closed and Common terminals. When the RFU lever is off its limit position, there should be continuity across terminal 1 and 2.

If conditions 'a', 'b', 'c' or 'd' are not met, loosen the switch trip cam and adjust its position until the microswitch is actuated and allowed to reset in the desired positions. The microswitch can also be adjusted by loosening the screws ③ and moving the microswitch around.

18. When the microswitch position is determined to be correct, tighten the microswitch screws ③ to 0.85 lbs.in [0.1Nm]. The switch trip cam screws should be tightened secure.

19. The microswitches come wired as shown in Figure 20. Compare this to the wiring noted in the original switches that was noted in step 1. If there is any difference, make necessary adjustments at the junction box to ensure the same functionality of the microswitches. Do not de-solder the cable at the microswitch terminal and adjust conductor position.

NOTICE

Do not de-solder microswitch conductors. Soldering the microswitch leads requires special tooling and techniques to ensure the microswitches are not damaged. If you require microswitches wired in a different configuration than supplied in the microswitch kit, contact the Kobelt Factory for more information.

20. Route the microswitch cable:
 - a. Refer to Figure 20 for the recommended wire routing route to ensure the wiring are free of any moving parts.
 - b. Install cable ties to secure the switch conductors
 - i. Attach the cable ties as shown in Figure 20.
 - ii. Secure excess conductor length either to one of the other cables coming from a gland or with the included adhesive switch mount.
 - c. Tighten the cable gland to fully secure and seal the cable assembly.
21. Refer to section 5 for recommissioning the RFU once all the faulty switches have been replaced.

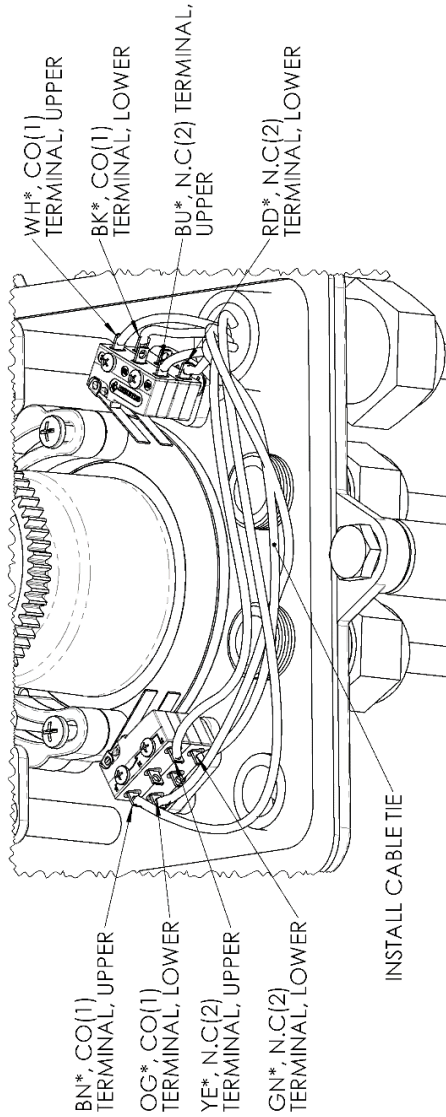

Figure 20: Default factory wiring, four switch model, 7174-BG shown.

(Intentionally Blank)

KOBELT

Kobelt Manufacturing Co. Ltd.

8238 129th Street
Surrey, British Columbia,
Canada, V3W 0A6

Sales Tel: +1-604-572-3935

Fax: +1-604-590-8313

Email: sales@kobelt.com

Website: www.kobelt.com

Made in Canada / Printed in Canada