

5030-SA | SPRING APPLIED AIR RELEASED CALIPER DISC BRAKE



KEY BENEFITS

Bronze & stainless steel construction

Rapid brake pad change out

Well matched to Kobelt's standard range of 4" x 7" ventilated discs

Putting you in control.

Constructed entirely of bronze and stainless steel, Kobelt's spring applied disc brakes are built to last in the harshest, most corrosive conditions.

The brake features a shoe design which allows the brake pads to be easily and quickly changed while leaving the caliper in place.

Available with several options, these caliper disc brakes are well suited for parking or emergency braking duty on hoists, winches and more.

SPECIFICATIONS

PART NO.	NORMAL FORCE ¹	PRESSURES	
		RELEASE	HOLD-OFF
5030-SA	36,170 lbs [160.9 KN]	79 psi [5.4 bar]	70 psi [4.8 bar]
5030-SA70	30,960 lbs [137.8 KN]	66 psi [4.5 bar]	60 psi [4.1 bar]
5030-SA55	25,980 lbs [115.6 KN]	53 psi [3.6 bar]	44 psi [3.1 bar]

Maximum Pressure: 150 psi [10.3 bar]

Port Size: -8 ORB

Actuator Volume: 275 in³ [4504 cc]

Temperature Range: -40°F...+131°F
-40°C...+55°C

Disc Thickness: 4 in [102 mm]

Max Running Clearance: .08 in [2.0 mm]

Minimum Disc Diameter: 50 in [1270 mm]

Maximum Disc Diameter²: 216 in [5486 mm]

Weight: 692 lbs [314 kg]

¹Torque:

$$T_B = 2F_N\mu \left(\frac{OD-9.50}{24} \right)$$

Where:

T_B = brake torque (ft-lbf)

F_N = normal force (lbf)

μ = coefficient of friction
= 0.38 (ferrous)
= 0.35 (nonferrous)

Friction values are theoretical and for reference only. They are based on properly bedded and burnished linings acting on a rotor at 20°C, manufactured to required specifications.

OD = brake disc diameter (in)

²Requires a minimum 9.00 in [229 mm] wide face

SPECIFICATIONS

FOOT MOUNTED VERSION

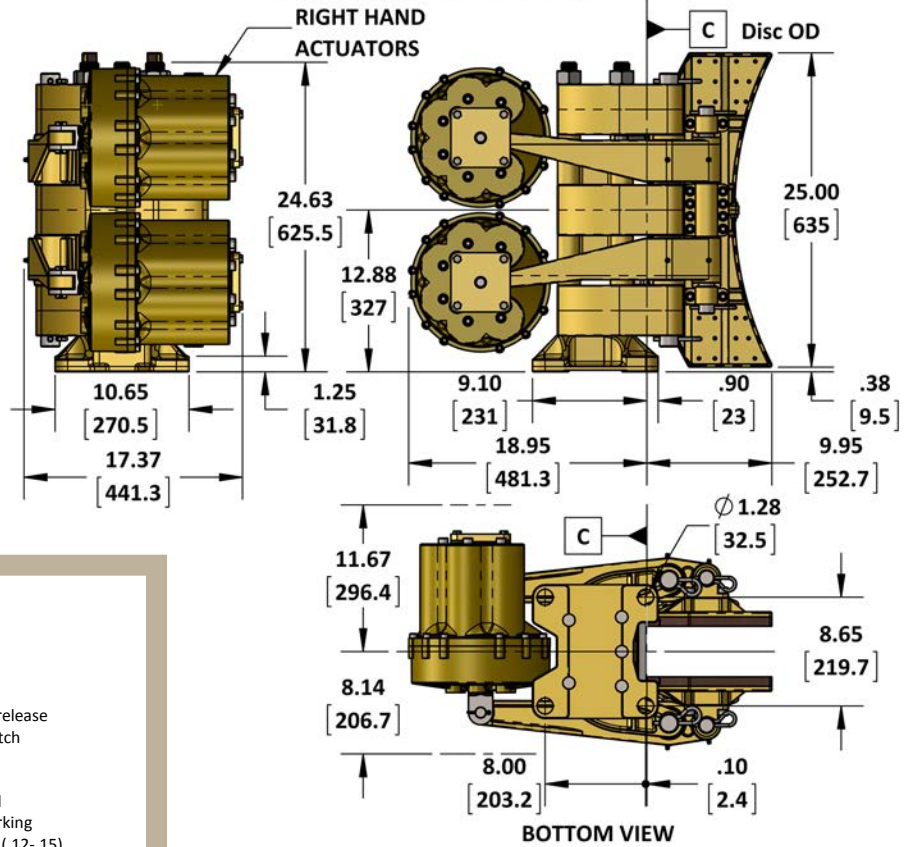

SIDE MOUNTED VERSION

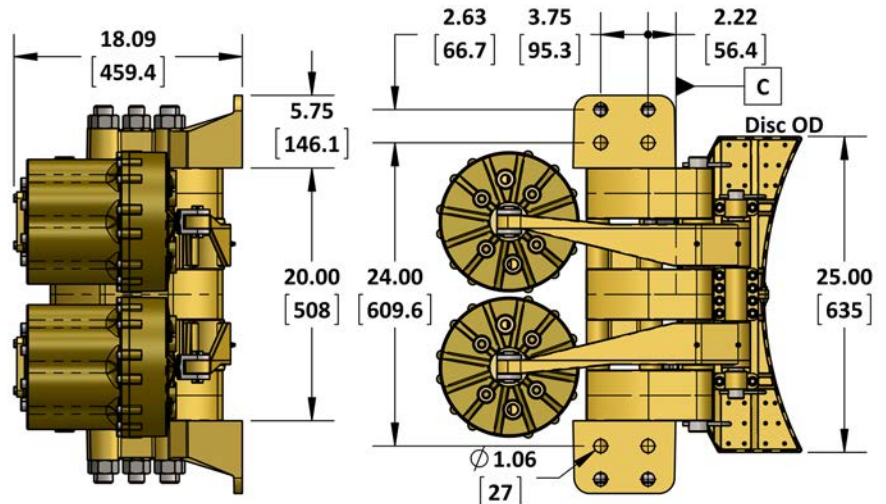
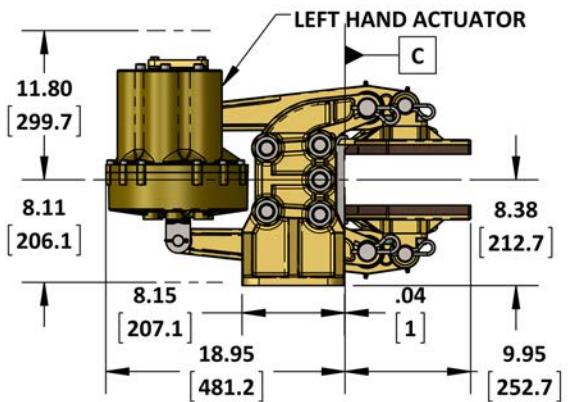

Brake Model Code Key

5030- [] - [] - [] - [] - []

Added options

- R = manual release
- LS = limit switch

Friction material

- (blank) = standard
- N = non-sparking
- C = low COF (.12-.15)
- E = mid COF (.25-.28)

Disc thickness

- (blank) = 4.000 in
- 350 = 3.500 in
- 300 = 3.000 in
- 250 = 2.500 in
- 200 = 2.000 in

Actuator handing

- LH = springs on left hand side
- RH = springs on right hand side

Mounting code

- (blank) = foot mounted
- W = side mounted

Actuator code

- SA = 79 psi release
- SA70 = 66 psi release
- SA55 = 53 psi release

PARTS LISTING

5030-SA Caliper Brake

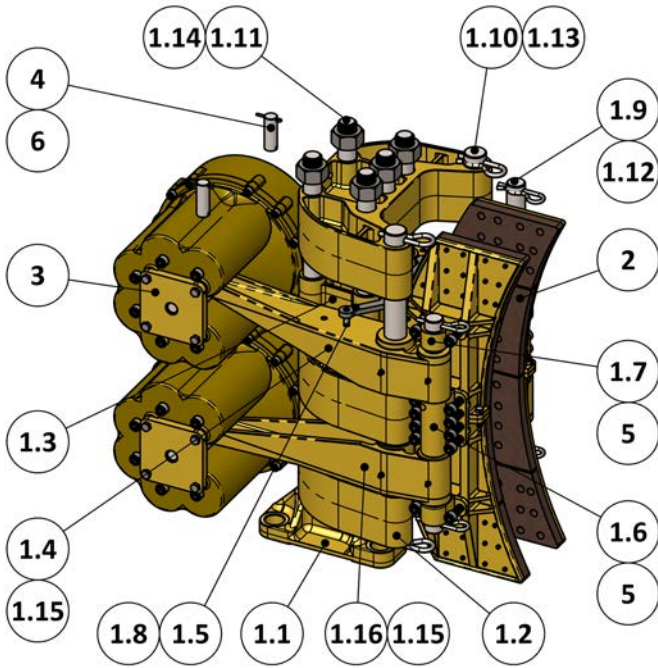

5030-SAW Caliper Brake

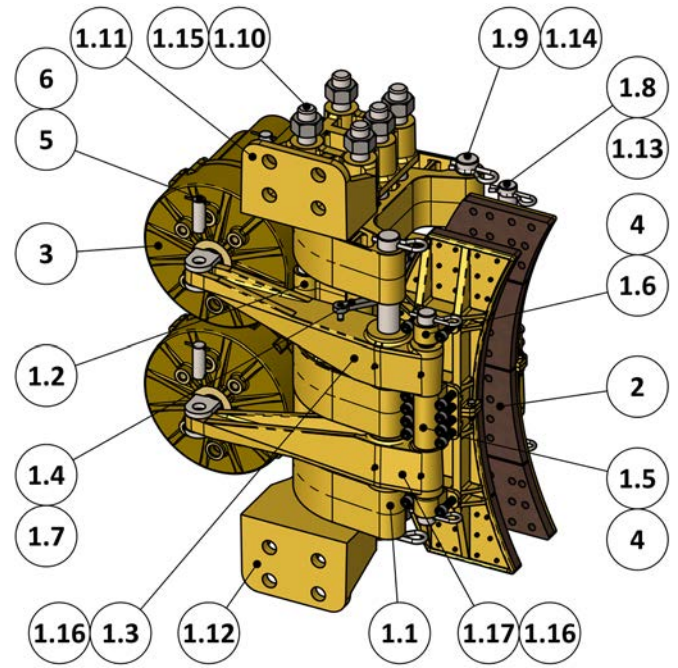

ITEM	QTY.	PART NUMBER	5030-SA DESCRIPTION
1	1	5030-SUB	SUB-ASSEMBLY, 5030 CALIPER
1.1	1	5029-0001	FOOT, 5029 / 5030 CALIPER
1.2	3	5029-0002	SADDLE, 5029 CALIPER
1.3	2	5029-0003	SPACER, 5029 CALIPER
1.4	2	5030-0004L	LEVER, LEFT HAND, 5030 CALIPER BRAKE
1.5	2	5029-0011	BALANCING LINK, 5029 CALIPER
1.6	2	5029-0013	PIVOT BLOCK, INNER, 5029 CALIPER
1.7	4	5029-0014	PIVOT BLOCK, OUTER, 5029 CALIPER
1.8	2	5029-0016	LINK PIN, 5029 - 5049 CALIPERS
1.9	2	5029-0021	SHOE PIN, 5029 CALIPER
1.10	2	5029-0022	SADDLE PIN, 5029 CALIPER
1.11	5	5029-0023	TIE ROD, 5029 CALIPER
1.12	4	1039-0470	HITCH PIN, 1/4 X 4-1/4, STEEL
1.13	4	1039-0553	HITCH PIN, 5/16 X 4, STEEL
1.14	5	1022-0125	HEX NUT, 1-3/4"-7 UNC, 18-8
1.15	8	1501-0301	GREASE NIPPLE, 1/4-28
1.16	2	5030-0004R	LEVER, RIGHT HAND, 5030 CALIPER BRAKE
2	2	5030-LS	SHOE ASSEMBLY, 5030 CALIPER
3	2	6237	ACTUATOR ASSEMBLY, SPRING / AIR
4	4	6136-0006	CLEVIS PIN, 5029/5030
5	24	1002-1420	SCREW, SKT HD, 1/2-13 UNC X 1-1/4, SS
6	8	1026-0624	COTTER PIN, 5/32 x 1-1/2, SS

ITEM	QTY.	PART NUMBER	5030-SAW DESCRIPTION
1	1	5030-SUB-W	SUB-ASSEMBLY, 5030 CALIPER, SIDE MOUNT
1.1	3	5029-0002	SADDLE, 5029 CALIPER
1.2	2	5029-0003	SPACER, 5029 CALIPER
1.3	2	5030-0004L	LEVER, LEFT HAND, 5030 CALIPER BRAKE
1.4	2	5029-0011	BALANCING LINK, 5029 CALIPER
1.5	2	5029-0013	PIVOT BLOCK, INNER, 5029 CALIPER
1.6	4	5029-0014	PIVOT BLOCK, OUTER, 5029 CALIPER
1.7	2	5029-0016	LINK PIN, 5029 - 5049 CALIPERS
1.8	2	5029-0021	SHOE PIN, 5029 CALIPER
1.9	2	5029-0022	SADDLE PIN, 5029 CALIPER
1.10	5	5029-0023-S	TIE ROD, 5029 SIDE MOUNTED CALIPER
1.11	1	5029-1001L	SIDE MOUNT FOOT, LEFT HAND, 5029 CALIPER
1.12	1	5029-1001R	SIDE MOUNT FOOT, RIGHT HAND, 5029 CALIPER
1.13	4	1039-0470	HITCH PIN, 1/4 X 4-1/4, STEEL
1.14	4	1039-0553	HITCH PIN, 5/16 X 4, STEEL
1.15	10	1022-0125	HEX NUT, 1-3/4"-7 UNC, 18-8
1.16	8	1501-0301	GREASE NIPPLE, 1/4-28
1.17	2	5030-0004R	LEVER, RIGHT HAND, 5030 CALIPER BRAKE
2	2	5030-LS	SHOE ASSEMBLY, 5030 CALIPER
3	2	6237	ACTUATOR ASSEMBLY, SPRING / AIR
4	24	1002-1420	SCREW, SKT HD, 1/2-13 UNC X 1-1/4, SS
5	4	6136-0006	CLEVIS PIN, 5029/5030
6	8	1026-0624	COTTER PIN, 5/32 x 1-1/2, SS

PARTS LISTING

6237 Actuator

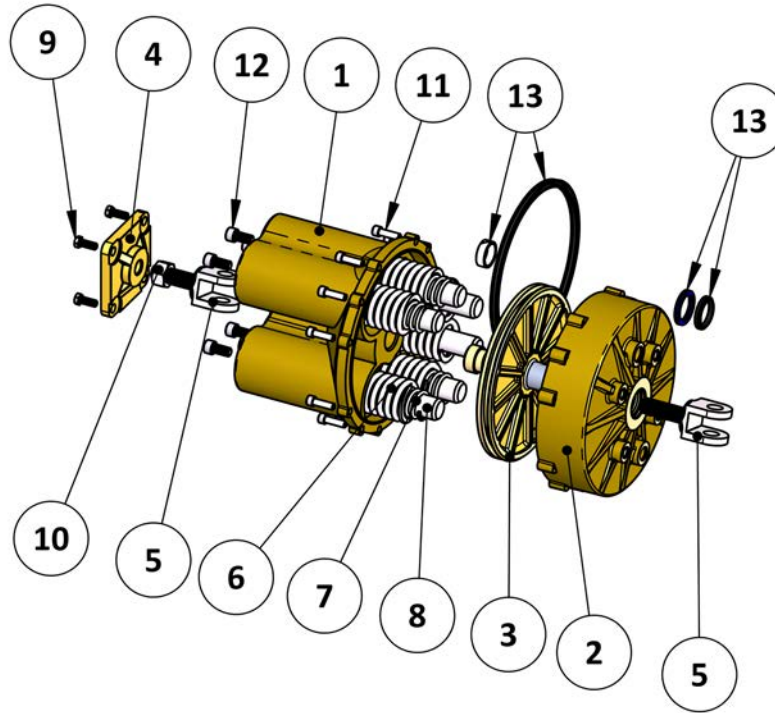

ITEM	QTY.	PART NUMBER	6237 DESCRIPTION
1	1	6238-0001	SPRING POT, 6238 ACTUATOR
2	1	6237-0002	CYLINDER HEAD, 6237 ACTUATOR
3	1	6237-0003-K	PISTON, 6237 ACTUATOR
4	1	6242-0003	BRACKET, CLEVIS, 7/8 UNC
5	2	6242-0005	CLEVIS, 7/8" DIA.
6	6	1201-0236	SPRING, COMPRESSION, 2.47 OD X .34 WIRE
7	4	1201-0232	SPRING, COMPRESSION, 1.70 OD X .28 WIRE
8	6	6242-0006	SPRING GUIDE, 6237 ACTUATOR
9	4	1001-1216	SCREW, CAP, HEX HD, 3/8-16 UNC X 1, SS
10	1	1041-10088	HN, 7/8-9 UNC, GR 5
11	12	1002-1220	SCREW, SKT HD, 3/8-16 UNC X 1-1/4, SS
12	6	1002-1416	SCREW, CAP, SCKT HD, 1/2-13 x 1, SS
13	1	6237-RK	SEAL KIT, 6237 ACTUATOR

Note: Parts lists are applicable to standard models only.